



Clipsal Lifesaver® Smoke Alarm

Installation/Operating Instructions and Warranty

755 Ionisation Series

240V a.c. Ionisation Smoke Alarm with battery backup

Suitable for single use or interconnection of up to 40 alarms.

Tested and passed to AS3786 — 1993.

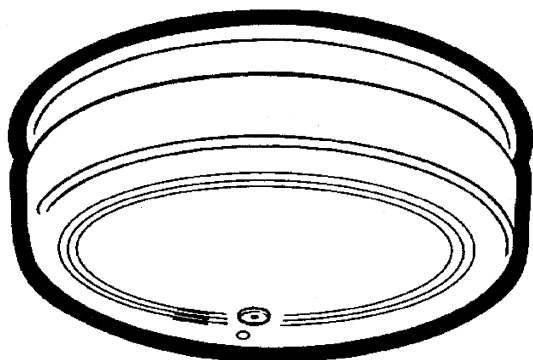

Important: Please leave this manual with the owner.

SMOKE ALARM DESCRIPTION

- Model 755 Ionisation 240V~ Smoke Alarm with 9V non-rechargeable alkaline battery backup.
- Model 755L Ionisation 240V~ Smoke Alarm with 9V non-rechargeable lithium battery backup.
- Model 755RL Ionisation 240V~ Smoke Alarm with 12V rechargeable lithium battery backup.

Thank you for purchasing a quality Clipsal Lifesaver® 755 Series Smoke Alarm. The 755 Series are mains powered smoke alarms, with a battery backup that will operate in the event of a mains power failure. The alarm will sound when smoke produced at the start of a fire enters the unit's detection chamber.

These units are not designed to detect heat or flame. A 5 year warranty (excluding batteries) is included. The non-chargeable lithium battery should be renewed at least every seven years.

Please read the following instructions carefully to ensure correct installation and maintenance.

Installation of the Clipsal Lifesaver® 755 Series Smoke Alarm must be carried out by a licensed electrician or similarly qualified person to SAA Wiring Rules (AS3000) and relevant Building Codes.

All ionisation Smoke Alarms use an extremely small amount of a radioactive element in their ionization chambers. Accordingly, this product contains 1 micorcurie of Americium 241, a radioactive material, and is manufactured in compliance with U.S. NRC safety criteria in 10CFR 32.27. The purchaser is exempt from any regulatory requirements (U.S. License No. 12-15537-02E). Do not attempt to remove or tamper with this radioactive source. Never try to repair or dispose of the unit yourself. Return it to the supplier for repairs or safe disposal. It is illegal to send products containing radioactivity through Australia Post. Check for similar conditions with any other forwarding agency before sending this product to the supplier.

SMOKE ALARMS HAVE LIMITATIONS

The Clipsal Lifesaver® Series Smoke Alarm is not fool-proof and is not warranted to protect lives or property from fire. Smoke Alarms are not a substitute for insurance. In addition, it is possible for the Smoke Alarm to fail at any time.

FOR THIS REASON YOU MUST TEST THE SMOKE ALARM WEEKLY AND REPLACE EVERY TEN YEARS.

RECOMMENDED LOCATIONS OF ALARMS

The Clipsal Lifesaver® 755 Series Smoke Alarms are domestic units designed to be mounted on ceilings in single or multi-storey residential dwellings, such as houses, home units and apartments. If the alarm cannot be installed on the ceiling, wall mounting is acceptable in most instances. Recommended locations are as follows:

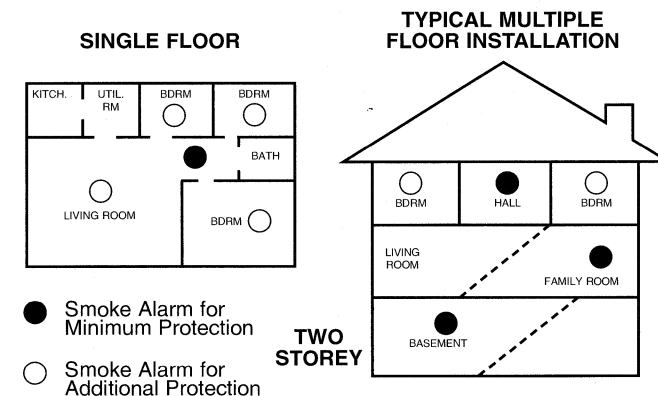

- Install at least one Smoke Alarm on each level or storey of a multi-storey dwelling.
- Smoke Alarm should be installed in the immediate vicinity of the bedrooms. If there is more than one sleeping area, locate additional alarms in the immediate vicinity of each of these areas.
- Sleeping areas are often located furthest from the exits of a house. Therefore, Smoke Alarms should be installed on all exit routes from bedrooms.
- A Smoke Alarm should be installed inside every room in which a smoker sleeps and inside any room where a person sleeps with the door closed.
- A closed door can stop smoke easily reaching the alarm and can prevent the occupant hearing the alarm sounding.
- Install additional alarms in hallways that are longer than 9 metres (30 feet).
- Smoke Alarms should preferably be mounted on the ceiling, not less than 600mm (2 feet) from any corner.
- If the alarm is to be mounted on a wall, install it not less than 300mm and not more than 500mm from the ceiling and no closer than 600mm from any corner.

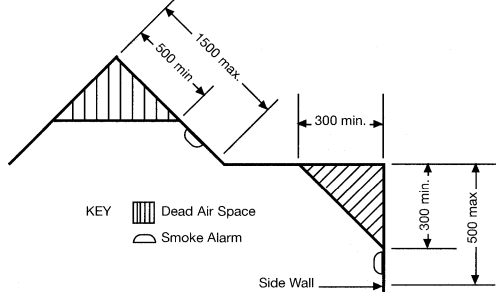

LOCATIONS TO AVOID

Installing a Smoke Alarm in an unsuitable location creates two main problems.

1. Obstructions can prevent the alarm from giving early warning in the event of a fire.
2. Its location may lead to nuisance (false) alarms.

To avoid these situations, Clipsal Lifesaver® 755 Series Smoke Alarms should not be installed in any of the following locations:

- The garage. Combustible products are present in the air when you start and run your vehicle's engine.
- In front of forced air movement from air-conditioners, heaters, fans, etc.
- In dead air spaces where early smoke may not enter. e.g. upper sections of sloping or 'A' frame ceilings or exposed ceiling beams, where air does not circulate.
- In dusty areas. Dust may cause a Smoke Alarm to false alarm or even fail to alarm.
- In spray painting areas.
- In areas where temperatures may fall below 5°C or rise above 45°C.
- In areas where relative humidity may fall below 10% or rise above 93%.
- In or near very humid areas such as bathrooms. Moisture can cause false alarms.
- Near hot water heaters, space heaters or fireplaces.
- In any area that attracts insects. Some lights attract insects, particularly fluorescent and mercury vapour lamps.
- When installing a Smoke Alarm on the ceiling, do not install it near any protrusions that may prevent smoke spreading quickly to the alarm.

LOCATING A SMOKE ALARM IN A CARAVAN OR MOBILE HOME

- Follow the recommended locations as detailed under the heading:
- "Recommended Locations For Alarms" when installing in caravans or mobile homes.
- Many mobile homes may not be well insulated, enabling

extreme heat or cold to be transferred from outside the home through the walls and roof. This may create a thermal barrier which can prevent smoke from reaching a Smoke Alarm mounted on the ceiling. If this situation exists, install the Smoke Alarm on an inside partition between 300mm and 500mm from the ceiling.

- If you are not sure about insulation in a mobile home, or if you notice the walls and ceilings are either hot or cold, install the alarm on an inside wall. For minimum protection, install one alarm close to the bedrooms. For additional protection, refer to the single floor plan on page 3.
- In mobile homes and caravans it is particularly important to install Smoke Alarms as far away as possible from cooking areas to reduce the potential for nuisance alarms.
- Other areas to avoid are listed under the heading - "Locations to Avoid".

BUILT-IN FALSE ALARM CONTROL — Warning

Before using the alarm's False Alarm feature, fully identify the source of the smoke and make certain that the area is safe. Nuisance sources such as kitchen cooking areas can cause nuisance or false alarms. Built into Clipsal Lifesaver® 755 Series Smoke Alarms is a special False Alarm feature that lets you silence false alarms from nuisance sources.

Features

- The False Alarm control will temporarily silence the alarm for approximately 15 minutes.
- After 15 minutes the unit will automatically revert to the fully alert mode.
- Very dense smoke will override the Hush control and sound the alarm.
- The False Alarm feature can be used repeatedly to silence the alarm until the air is cleared.
- This feature is to be used only when a known condition (e.g. smoke from cooking) activates the alarm.
- To operate, push the False Alarm/test button. The alarm will silence immediately and the red light blinks approximately every 10 seconds for the next 15 minutes.
- At the end of 15 minutes the Smoke Alarm will beep twice. This signals the end of the False Alarm control.
- It will then automatically revert to the fully alert condition. If smoke particles are still present, the alarm will sound again.
- If interconnected alarms are installed, the unit that detects the smoke and sounds the alarm cannot be inadvertently silenced by the False Alarm/TEST button of other units. In this case all of the alarms will continue to

sound for as long as smoke is detected or until the False Alarm/TEST button of the triggering alarm is pressed.

- The Smoke Alarm produces an audible sound of 85 decibel alarm at 3 metres.

INSTALLATION

The Clipsal Lifesaver® 755 Series Smoke Alarms are a 240V a.c. unit with 9V d.c. battery backup. Unless a 9V d.c. battery is installed, disconnection of this unit from its mounting plate or loss of mains power will render this device inoperative.

This Smoke Alarm must be connected to a continuous 240V a.c. 50Hz supply which cannot be inadvertently switched off. Interconnected alarms must be wired on the same final sub-circuit.

WIRING INSTRUCTIONS

- 240V a.c. installation must be carried out by a licensed electrician or similarly qualified person in accordance with the SAA Wiring Rules (AS3000).
- Do not conduct an insulation resistance test to any circuit with the Smoke Alarms connected (if supplied).
- It is important that the alarm is wired correctly and fitted with a 9V d.c. battery backup to ensure correct operation.

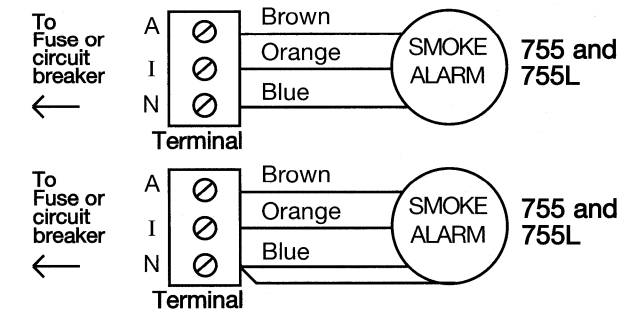

- Turn to remove the mounting plate as indicated by arrows.
- Fix mounting plate in position.
- Fit off the terminal connector.
- Connect 9V battery (included Models 755 and 755L).
- Connect circuit wiring to terminal connector as set out in diagram and close the junction box over the terminal connector.
- Fit the Smoke Alarm to the mounting plate, rotate until it snaps into place.
- Turn on power and check the green light on alarm cover. It should be lit when mains connected.
- Test alarm by pushing on False Alarm/TEST button in indicated location, the alarm will sound by holding down the False Alarm/ TEST button for 5 seconds.

MULTIPLE ALARM WIRING

- Use 1.5mm² minimum solid or stranded wire with a rating of 240V. When interconnecting, the maximum wire length between any two Smoke Alarms is 450m for 1.5mm² or 1200m for 2.0mm² (20 OHMS loop resistance).
- This Smoke Alarm may be interconnected with as many as 39 Clipsal Lifesaver or 755 Series Smoke Alarms. Do not connect to any other type or model Smoke Alarm.
- Connect Smoke Alarms to a same phase.

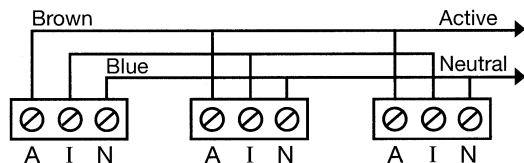

Connecting the switch wire terminal in any other way to that shown in this instruction may result in damage to the alarm, failure to operate or an electrical shock hazard. It will also void the warranty.

Fitting Tamper Pin

A tamper resistant feature on the Smoke Alarm may be used to prevent unauthorised removal of the Smoke Alarm from the mounting plate.

- From the back of the Smoke Alarm remove the mounting plate. Twist out and remove one of the pins moulded into the plate. (Both pins are exactly the same).
- Position Smoke Alarm to mounting plate and turn clockwise to lock into place. To engage tamper resist feature, insert pin into notch on edge of Smoke Alarm.

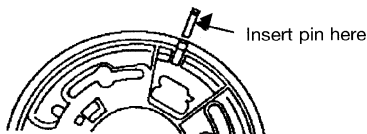

BATTERY INSTALLATION AND REPLACEMENT

The Clipsal Lifesaver® 755 Series Smoke Alarm uses one 9V d.c. battery which automatically provides backup power for the alarm in the event of the mains power failing. A fresh battery will operate the alarm for approximately one to three months with a.c. power off. This Smoke Alarm has a low/missing battery indicator which will 'beep' at intervals of approximately 60 seconds. It is vital for your safety that you renew the battery when this occurs. An inactive alarm will not save lives. Replace the battery with a new one at least every year (755) and every seven years (755L) to ensure correct operation. The Smoke Alarm cannot be fitted to the mounting plate if the Battery is missing.

1. To replace the battery, rotate the Smoke Alarm in the direction shown by the arrow on the unit's cover.
2. Disconnect the mains wiring by pulling the connector away from the Smoke Alarm.
3. Remove the battery from compartment.
4. Connect a new battery and place it into the battery compartment.
5. Replace the mains connector, and fix Smoke Alarm in place by rotating it onto mounting plate.

Use only the following batteries as replacements: Model 755 Eveready 522, 216, 1222 or Duracell MN 1604 — Model 755L Ultralife U9VL-J.

Warning: In Australia, smoke alarm installation and battery replacement must only be performed by a licensed electrician. Using inferior batteries or the incorrect type may cause the alarm to malfunction. When replacing the battery and refitting the alarm to the mounting plate make sure that it is fully connected and flush with the mounting plate.

NOTE: 755RL Rechargeable lithium batteries are permanently mounted and sealed in the tamper-proof housing. These cells are designed to last the useful life of the Smoke Alarm of 10 years.

OPERATION AND TESTING

- The Clipsal Lifesaver® 755 Series Smoke Alarms are operational once all of the connections are correctly made, the 9V battery installed and mains power restored.
- Test the alarm by pushing the HUSH/TEST button for 5 seconds. The alarm should sound simultaneously.
- This test should be done at least once a week to ensure that the alarm is operating correctly.
- If interconnected alarms are installed, pushing the False Alarm/TEST button on one unit should cause all interconnected units to sound.
- If the alarm does not sound, check the wiring, 9V battery, fuses or circuit breaker and make sure that the alarm is connected to a 240V a.c. supply which cannot be inadvertently turned off.
- The green light indicates that the unit is operating with a.c. power. If this light is off, the a.c. power is off and the backup battery will operate the unit.
- You will not be safeguarded if the a.c. power goes off and the unit is not fitted with a fresh battery.
- The red light should flash once approximately every 60 seconds to indicate the unit is functioning and alert. It will flash rapidly when the unit goes into alarm. The flashing light and pulsating loud alarm will continue until the air is cleared. For interconnected alarms, only the unit which senses smoke (or is being tested) will flash rapidly. All other units will sound their alarms but not flash rapidly.
- Do not apply excessive force to HUSH/TEST button. Doing so may damage the unit and void the warranty.

- Never use an open flame of any type to test your alarm. You may damage the alarm or set fire to your home. Operating the HUSH/TEST button will check for correct functioning.

MAINTENANCE AND CLEANING

- If a zinc oxide or alkaline battery is used, the battery should be renewed at least once a year.
- If a lithium battery is used, then the battery should be renewed at least every seven years.
- The Clipsal Lifesaver® 755 Series Smoke Alarms are virtually maintenance free. However, vacuuming the unit at least once every six months will remove dust.
- Wipe the enclosure clean with a water moistened cloth. Do not immerse this unit or use household cleaners. Do not apply paint or spray with any liquid.
- All Clipsal smoke alarms are manufactured and tested to rigorous quality standards and have a minimum life expectancy of 10 years. However, for your safety we recommend replacing your smoke alarm with a new Clipsal unit after 10 years. This will ensure that you are always protected by a Smoke Alarm that's operating within the limits of its life expectancy.

REPAIRS AND SERVICE

This Smoke Alarm has no user serviceable parts. Dangerous voltages are contained within, so do not attempt to repair this unit yourself. Instead, this Smoke Alarm should be returned to the supplier for service. Never send this unit through the post.

RETURN UNIT TO SUPPLIER OR DEPARTMENT OF HEALTH FOR DISPOSAL.

LIMITATIONS OF SMOKE ALARMS

When installed and maintained correctly, Smoke Alarms are an excellent and inexpensive way of providing your family with an early warning of possible fires.

It must be remembered, however, that Smoke Alarms do have their limitations and that this product should not be a substitute for basic safety precautions and fire prevention.

- Smoke Alarms cannot provide an alarm if smoke does not reach the unit. It may not sense a fire that is on the other side of a closed door, or fires that start in chimneys, walls, ceilings, roofs, or on another storey.
- Alarms located outside bedrooms, on the other side of a closed door may not wake a sound sleeper.
- Smoke Alarms must be tested regularly to ensure that batteries and alarm circuits are in good condition. A Smoke Alarm with a flat or missing battery offers no protection in the event of a mains power failure.
- **Smoke Alarms do have a limited life and should be replaced after 10 years service.**

- People with impaired hearing are advised to use special purpose Smoke alarms that use flashing lights or vibrating devices to indicate alarm conditions.

DEVELOPING AN ESCAPE PLAN

A mains powered Smoke Alarm with battery backup, correctly installed and maintained is the most effective way of giving your family early warning of a fire. Other precautions are to reduce the risks of a fire starting in your home and to develop a fire escape plan with all family members.

Here are some suggestions for developing your escape plan:

1. Make a floor plan which clearly indicates all doors and windows in your home and at least two escape routes from each room. Multi-storey dwellings require special attention. For instance, upper storey windows may need a chain ladder or other fire stairway as a means of exit.
2. Determine a place outside your home (e.g. the letter box or front fence) where all family members can assemble if a fire occurs.
3. Discuss your escape plan with all members of your family. Show everyone, particularly young children, what to do in case of a fire.
4. Make sure all family members are familiar with the sound of the Smoke Alarm.
5. At least every six months, sound the alarm and practice your family's fire drill.

Remember:

In the event of a fire, you may not be able to reach your children. Therefore, it is important for all family members, including small children, to know exactly what to do.

WHAT TO DO IF THE ALARM SOUNDS

1. Leave immediately, following your family's escape plan.
2. As you leave, don't open any inside doors without first feeling its surface. If the door is hot, or if you see smoke coming through the cracks, do not open the door. Use an alternative exit.
3. If the inside of the door is cool, place your shoulder against it, open it slightly and be ready to slam it shut if heat and smoke rush in.
4. If the air is smoky, stay as close to the floor as possible.
5. Breathe shallowly through a cloth, which if possible should be wet.
6. Once outside, go to your pre-selected assembly area and make sure everyone else is there.
7. Call the Fire Service from a neighbour's home - never from your own.
8. Do not return to your home until fire officials give you permission to do so.

For further information on fire safety, contact your local Fire Service.

TROUBLESHOOTING

To be carried out by licensed electrician or similarly qualified person.



DANGER:

Always turn off power at main fuse box or circuit breaker before taking trouble shooting action.



WARNING:

DO NOT disconnect battery or a.c. power to quieten an unwanted alarm. This will remove your protection. Fan the air or open a window to remove smoke or dust.

PROBLEM	SOLUTION
Smoke Alarm does not sound when tested. NOTE: Push Hush/test button for at least five (5) seconds while testing!	<ol style="list-style-type: none"> 1. Check that a.c. power is turned on and the green light is on. 2. Turn off power. Remove Smoke Alarm from mounting plate and: <ol style="list-style-type: none"> a. check that connector plug is securely attached. b. check that battery is properly attached to connector. (Models 755 and 755L only) 3. Clean Smoke Alarm.
Smoke Alarm beeps about once a minute. (Models 755 and 755L only) Model 755RP	<ol style="list-style-type: none"> 1. Turn off power and replace battery in the "Battery Installation and Replacement" section. 2. Clean Smoke Alarm. 3. Verify that the unit has been under mains operation for a minimum of 2 full days. If the beeping persists after the required charging period, return the unit for service.
Smoke Alarm sounds unwanted alarms when residents are cooking/taking showers, etc.	<ol style="list-style-type: none"> 1. Get an electrician to move Smoke Alarm to a new location. See "Recommended locations of alarms". 2. Clean Smoke Alarm.
Interconnected Smoke Alarms do not sound when system is tested.	<ol style="list-style-type: none"> 1. Press and hold TEST/HUSH button for at least three seconds after the first unit sounds. 2. Have an electrician check the connections if interconnected alarms still do not sound.

WARRANTY

The benefits conferred by this warranty are in addition to all other rights and remedies in respect of the product which the consumer has under the Trade Practices Act and similar State and Territory Laws.

The original purchaser of this Clipsal Lifesaver® 755 Series Smoke Alarm is provided with the following warranty and subject to the following conditions. Gerard Industries Pty Ltd warrant this product for a period of 5 years from the date of purchase for all parts defective in workmanship or materials. All defective parts will be replaced free of charge. The following exclusions do not preclude the purchaser from those statutory rights consumers have under the Trade Practices Act and similar State and Territory Laws.

WARRANTY CONDITIONS

1. This warranty is only valid for products installed according to the manufacturer's instructions.
2. This product must not be modified or changed in any way.
3. All wiring must be carried out by a licensed electrician or similarly qualified person and must be connected to the voltage requirements as specified in the ratings label.
4. The manufacturer does not accept liability for any direct or consequential damage, loss or other expense arising from misuse or incorrect installation and operation of this product.
5. Warranty will only be given on products with proof of purchase date e.g. original invoice.
6. This warranty does not extend to cover batteries or any faults caused by batteries when incorrectly installed, leaking or otherwise installed in non accordance with manufacturer's directions.

Note: It is illegal to send radioactive material through Australia Post. Send by courier.

Check for similar conditions with any forwarding agency before sending this product.

As a record of purchase, please complete the following details and file this information with your purchase invoice.

Clipsal Lifesaver Smoke Alarm

MODEL 755 755L 755RL

Serial Alarm _____

Purchased From _____

Date of Purchase _____

Product of Gerard Industries Pty Ltd ACN 007 873 529	Registered offices in all States: New South Wales (02) 794 9200 Victoria (03) 9207 3200 Queensland (07) 3267 8044 South Australia (08) 269 0555 Western Australia (09) 442 4444 Northern Territory (08) 8947 0278 Tasmania (003) 31 6951
Head Office 12 Park Terrace, Bowden, South Australia 5007 Telephone (08) 269 0511 Facsimile (08) 340 1724	