

# Assembly Manual for the

PLEASE READ DISCLAIMER CAREFULLY AS WE CAN ONLY GUARANTEE PARTS AND NOT THE LABOUR CONTENT YOU PROVIDE.

## AM STEREO DECODER

### K-6320

Reprinted in part by arrangement with Electronics Today International from their October, 1984 edition.

DICK SMITH  
HIT 

**This add-on module for AM tuners will decode both the Motorola and Harris system transmissions. While the technique is complicated it only takes three chips to do the job at the receiver!**

THERE HAS BEEN mention, from time to time in the technical media in this country, about the 'imminent' introduction of stereo transmission for AM broadcast stations. The last mention we made of it in ETI was in the June 1983 issue (page 12).

In 1983, some broadcast stations here began equipping for tests of the various systems. Some 14 commercial stations had installed AM stereo transmission equipment up to June 1984. But before we get into the details, let's back-track a little.

Proposals for stereo transmission systems for AM broadcasting on the mediumwave band (530-1650 kHz) first arose in the 1950s. Over the intervening years, some five systems have been proposed by various companies, viz: RCA (Belar system), Magnavox, Kahn, Harris and Motorola.

In the late 1970s, the US Federal Communications Commission (FCC) authorised stations in North America to instal a system or systems of their choice and to conduct tests. Eventually, they authorised the Magnavox system only but later withdrew this following protests. The FCC later took the view "... let the market decide" and authorised US AM broadcasters to use any of the Magnavox, Kahn, Harris or Motorola systems. In July 1982, AM stereo broadcasting began in the US and hundreds of stations there are now on the air.

But this has left the various receiver manufacturers with a problem. How to provide a receiver which will decode all four transmission systems? Well, Sansui and Matsushita (National) have managed it, but it's not easy, especially if automatic decoding of all the systems is required. It seems that they've been able to provide automatic decoding for the Magnavox, Motorola and Harris systems, but decoding Kahn stereo transmissions has to be done by using a switch on the receiver.

### The local scene

In Australia, stations are equipped with different systems and all four extant systems have been tested on the air. Some stations have installed more than one system (but only use one at any particular time during tests). The broadcasters only await a decision by the Government on technical and operating standards before they go on the air with full stereo operation.

Department of Communications officers reported the results of engineering tests to a meeting of the Broadcasting Council in mid-June. The results obtained to that date, apparently, show that:

- AM stereo transmissions are feasible here.
- No one system is technically superior to any other.
- Available multi-system receivers can provide automatic decoding of the Magnavox, Motorola and Harris systems, but a switch has to be used to decode Kahn transmissions.

It seems the DOC's final engineering report will encompass a standard common to all four systems.

While the broadcasters, represented by the Federation of Australian Radio Broadcasters (FARB), is in favour of allowing all four systems to prevail and letting the marketplace decide, the receiver industry, under the auspices of the Australian Electrical and Electronics Manufacturers Association (AEEMA), plumps for the selection of a single system.

We haven't the space here to go into the pros and cons of the arguments either way, but the DOC was to make a decision in August or September. At the time this issue went to press (first week of September), no announcement had been made.

Note that the New Zealand authorities went for a single system standard for AM

stereo and stations there went on the air earlier this year using the Harris system.

### Our decision

Efforts over the past year to secure data on the transmission systems turned up some interesting articles, but not much practical circuitry on which a project could be based. Attempts to obtain a multi-system decoder chip proved fruitless. However, Motorola came to the party with a great deal of information on the various systems, with (fairly naturally) emphasis placed on the advantages of their system and decoder chip. The latter, designated the MC13020P became available locally early in 1984 and we obtained some samples to play with.

However, a single system decoder was clearly pretty limiting. So we kept our eyes peeled on the overseas press, looking for leads to multi-standard decoder systems and devices.

As chances had it, the R&D manager at Dick Smith Electronics, Gary Crapp, came upon some information from the Harris corporation Broadcast Division on using the Motorola MC13020P chip to decode Harris system transmissions. Therein lay the makings of a dual-standard AM stereo decoder.

For the hobbyist, two systems are better than one and *definitely* better than none — which would have been the case if we'd held out for a multi-system decoder.

A Motorola/Harris decoder permits decoding AM stereo stations located in both Australia (Motorola or Harris) and New Zealand (Harris), so we can cater to our readers across the Tasman.

With some re-hashing of the circuit, a prototype was quickly 'lashed up' and put on the air. Success was ours after a few circuit and component adjustments and the project described here is the result.

# AM STEREO SYSTEMS — AN OVERVIEW, ENCODING AND DECODING

FIVE techniques have been devised for adding stereo to standard AM broadcast transmissions, known as: Belar (RCA), Magnavox, Kahn, Harris and Motorola.

The fundamental requirement for any AM stereo transmission system is the necessity to retain compatibility with existing receiving systems which employ a simple envelope detector. (The humble crystal set is the basic example). Hence, the two sound channels must be combined in some way on the transmission that permits separation by a special detector system, yet produces simple monoaural sound in a receiver having an envelope detector.

To accomplish this, all systems (with the exception of the Harris) combine the left and right channels into 'left plus right' (L+R) and transmit it as amplitude modulation. This provides the fundamental compatibility. Also, all systems combine the left and right channels in a subtraction process (L-R) which is then used to modulate the transmitter in some frequency, phase or quadrature fashion.

The latter are all forms of *angular* modulation which is not readily demodulated by ordinary AM radios to such a degree that it would bother reception, depending on the method used and the amount of modulation.

Although all the systems use L-R angular modulation to transmit information so that stereo audio can be decoded at the receiver, the precise method of generating the information determines the differences between the systems and their transmission and reception performance. Characteristics important to the broadcaster, licensing authority (DOC), receiver makers and the listener include spectrum occupancy, fidelity, stereo coverage and separation, noise performance, susceptibility to interference and receiver performance under heavy amplitude modulation.

## SYSTEM CATEGORIES

The five systems can be categorised in a variety of ways. Taking a lead from Motorola, three categories divide the systems as follows:

- Mixed Mode**
- Belar (RCA)
- Magnavox
- Phasing SSB**
- Kahn
- Quadrature**
- Harris
- Motorola

The *mixed mode* system employs amplitude modulation (AM) for the L+R signal with frequency or phase modulation of the carrier for the stereo L-R information. Propagation problems and receiver mistuning are said to adversely affect reception, giving rise to unacceptable distortion.

The Magnavox system, though, takes steps to reduce these effects, employing a 5 Hz 'pilot' tone to provide a reference for a wideband phase-locked loop synchronous detector.

The *phasing SSB* system of Kahn's is quite an elegant concept. Here the carrier is phase-modulated with the L-R signal and then amplitude modulated with the L+R signal. Some very sophisticated circuitry is used to produce the resultant carrier which has the left channel signal on one sideband and the right channel signal on the other. The transmitted signal can be received in various ways. A normal mono AM receiver tuned right onto the carrier will receive the normal AM envelope (the L+R signal). Stereo reception is obtained either by using a receiver with phase detection for separating out the L+R and L-R signals, or by using a receiver with two IF circuits, one tuned slightly above the carrier, the other slightly below.

Reception of Kahn signals suffer if the receiver is mistuned, but sophisticated modern circuitry can 'lock' the receiver to the station.

The *quadrature systems* basically comprise two AM transmitters, phase-locked together and with their outputs coupled together but with a phase difference of 90° between the two carriers (hence the term, quadrature). The audio from each transmitter can be separated at the receiving end by using phase-sensitive AM detectors.

However, the problem with quadrature modulation is that it produces distortion in normal AM envelope detectors, so with AM stereo it isn't directly compatible with all the existing receivers.

Motorola and Harris went about solving this problem in slightly different ways.

## MOTOROLA 'C-QUAM'

The Motorola compatible quadrature AM stereo system ('C-QUAM') takes the left and right audio channels, combines them and sends them to the AM transmitter's audio input. Thus, the mono (L+R) signal is transmitted and received as AM in the normal way, retaining compatibility. The L+R and L-R (subtraction) audio signals are then used to modulate two carriers which are on the same frequency but 90° out of phase. This signal then supplies the AM transmitter's RF stages.

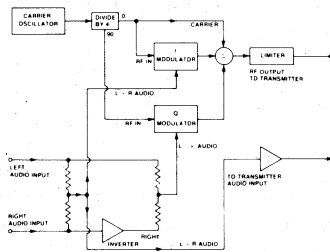

A block diagram of the Motorola C-QUAM transmitter system is shown in Figure 1. The L+R signal goes to the (0°) "I" quadrature modulator and the L-R signal goes to the (90°) "Q" quadrature modulator. The carrier oscillator is on four times the desired frequency and a

digital technique is used to generate the quadrature RF signals.

The carrier, the "I" modulator and "Q" modulator outputs are all summed and the result is a pure quadrature AM stereo signal.

Following the summing stage, the signal is passed through a limiter which 'strips' the AM components from it, leaving only the phase modulation "Q" sidebands.

Motorola point out that this is not the same as the simple output of the "Q" modulator because the addition of the "I" and "Q" balanced modulators produce some phase shifting not present in the output of the "Q" modulator alone.

The output of the limiter stage passes to the transmitter's RF drive stages.

Decoding this signal requires splitting the "I" and "Q" signals, generating the original L+R and L-R signals and then 'matrixing' them to produce the left and right stereo audio channels. The basic system block diagram is shown in Figure 2.

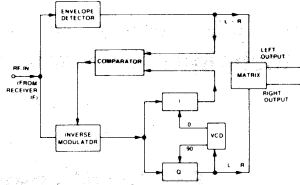

The received signal is demodulated two ways — with an envelope detector, giving the L+R signal, and with an "I" detector. The two signals are compared and the resultant 'error' signal used to gain modulate the inputs of the "I" and "Q" demodulators.

Motorola's Chris Payne explains the operation as follows: "When the transmitted signal is L+R (monaural, no stereo) the transmitted signal is pure AM or only "I" sidebands. In this case the envelope detector and the "I" demodulator see the same thing. There is no error signal, the input modulator does nothing and the signal passes through without change.

"However, when a left or right only signal is transmitted, both AM and PM is transmitted and the input signal is shifted in phase to the "I" demodulator and loses some of its "I" amplitude.

"The envelope detector sees no difference in the AM because of the phase modulation, and when the envelope detector and the "I" demodulator are compared, there is an error signal.

"The error signal pushes up the input level to the detector. This makes the input signal to the "I" and "Q" demodulators look like a pure quadrature signal and the audio output gives a perfect L-R signal.

"The demodulator output is combined with the envelope detector output in a matrix to give left and right audio out."

A 25 Hz pilot tone is added to the L-R signal at 4% modulation to

provide stereo reception by synchronous detection, even under bad signal conditions.

## HARRIS

The Harris corporation tried three systems in all, before settling on one. Their first attempt used a +/- 15° phase difference between the "I" and "Q" carriers. The reason being that, the closer the quadrature carriers are to no phase difference, the closer the transmitted signal is to AM. This provides compatibility, but reduces stereo coverage.

Their second attempt employed an audio companding scheme, compressing the amplitude range at the transmitter and expanding it at the receiver.

To control the expansion process in the receiver, Harris employed a variable frequency pilot tone in the L-R channel, varying from 55 Hz to 96 Hz. The frequency was proportional to the required gain control of the receiver expansion circuitry.

Thus, the low frequencies of the stereo audio had to be filtered below 200-300 Hz to allow for the pilot. The receiver decoder system is quite complex for this system and was not favoured for that reason.

The latest Harris system employs a 55 Hz fixed pilot tone. The transmitter encoding system is similar to Motorola's, but the audio is further processed so that the maximum angle of quadrature modulation is limited to obviate AM incompatibility problems under heavy modulation.

As the Harris system is similar to the Motorola system, a similar decoder may be used.

## ON THE AIR

The Harris system is employed in New Zealand, but we didn't know which stations were on the air at the time this went to press. New Zealand readers should check with their local stations to see who's running stereo and who isn't.

Some 20 stations throughout all states of Australia (except Tasmania, but they're always last) had been authorised for AM stereo operation when we went to press (early September).

By far the most popular system was the Harris, followed by Motorola. Kahn and Magnavox systems came well behind. Here follows a list of stations either on the air or who will shortly commence transmissions, categorised by system installed.

Motorola	Harris
2WS	2SM
3AK	2UE
3KZ	2NX
3UZ	2KO
5KA	3XY
<b>Kahn</b>	4BK
2CH	4BH
2UW	5AD
3AW	6IX
<b>Magnavox</b>	6PR
3MP	6PM
2UE	

Note that 2UE is testing both Harris and Magnavox systems.

## Project details

The project was designed to 'add on' to an existing hi-fi AM or AM/FM tuner or receiver. It is not suitable for adding to a simple portable or 'mantle' AM radio. They just don't have the required performance. But more of that later.

Decoding of either system is automatic and depends on discriminating between the 25 Hz Motorola system pilot tone and the 55 Hz Harris system pilot tone.

For ease of construction, a fairly open board layout was used. Apart from the Motorola MC13020P decoder chip, all parts are off-the-shelf items. The decoder chip's oscillator can employ either a coil-capacitor combination or a ceramic resonator. Both were tried successfully. The circuit and component overlay show the different methods.

A single-sided pc board was designed and, owing to the circuit complexity, 11 (or 12) links are necessary. But that's not too much of a burden. One capacitor has to be mounted under the board. It's a bypass for the supply rail to the MC13020P and this keeps its leads to an absolute minimum, ensuring effective bypassing. Note that all the ICs face the same way.

The project takes its input from the AM receiver's last IF stage. As the signal level at this point will be different in different receivers, a trimpot has been employed on the input stage. It has to be set 'on the air'. For effective stereo reception, the signal level here at the input needs to be above 150 mV RMS, which is generally easily obtainable in most good quality tuners or receivers. The decoder's input impedance is about 5k.

The AGC output has been made available via a pin on the pc board. If your tuner/receiver employs a positive AGC voltage, this output may provide more effective AGC control.

If you require it, you can incorporate a switch to 'force' mono-only reception. All it requires is a switch between the FORCED MONO INPUT and the +8 Vdc supply rail.

An on-board three-terminal regulator provides the appropriate supply voltage and prevents supply variations from affecting the decoder's performance.

An off-board 'stereo' indicator can be incorporated if you wish.

## Construction

As always, the first thing to do is check the pc board. See that all the holes are drilled and are the correct diameter. The four mounting holes are the largest. Note that the holes for the three pins on the trimpot, RV1, and the voltage regulator (IC1) pins are slightly larger than the other component holes, as are the two for the coil shield can.

Construction should proceed with reference to the component overlay. Commence with the links. There are 11 of them (12 if you're using the ceramic resonator). Use 22 or 24 gauge tinned copper wire. Three should be sleeved with 'spaghetti' insulation: The one adjacent to R57, the one running past R23 and R29, and the one adjacent to IC2 and R49.

You can solder all the transistors in next. See that they are all correctly oriented. Then you can solder in all the resistors and the three diodes. Follow up with all the capacitors. *Don't forget C8.* It mounts on the copper side of the board, beneath IC2 (between pins 6 and 16; there are pads on the board for it).

The trimpot, RV1, and the ICs may be mounted next. Take care you get the ICs in the right way round (especially IC1). You

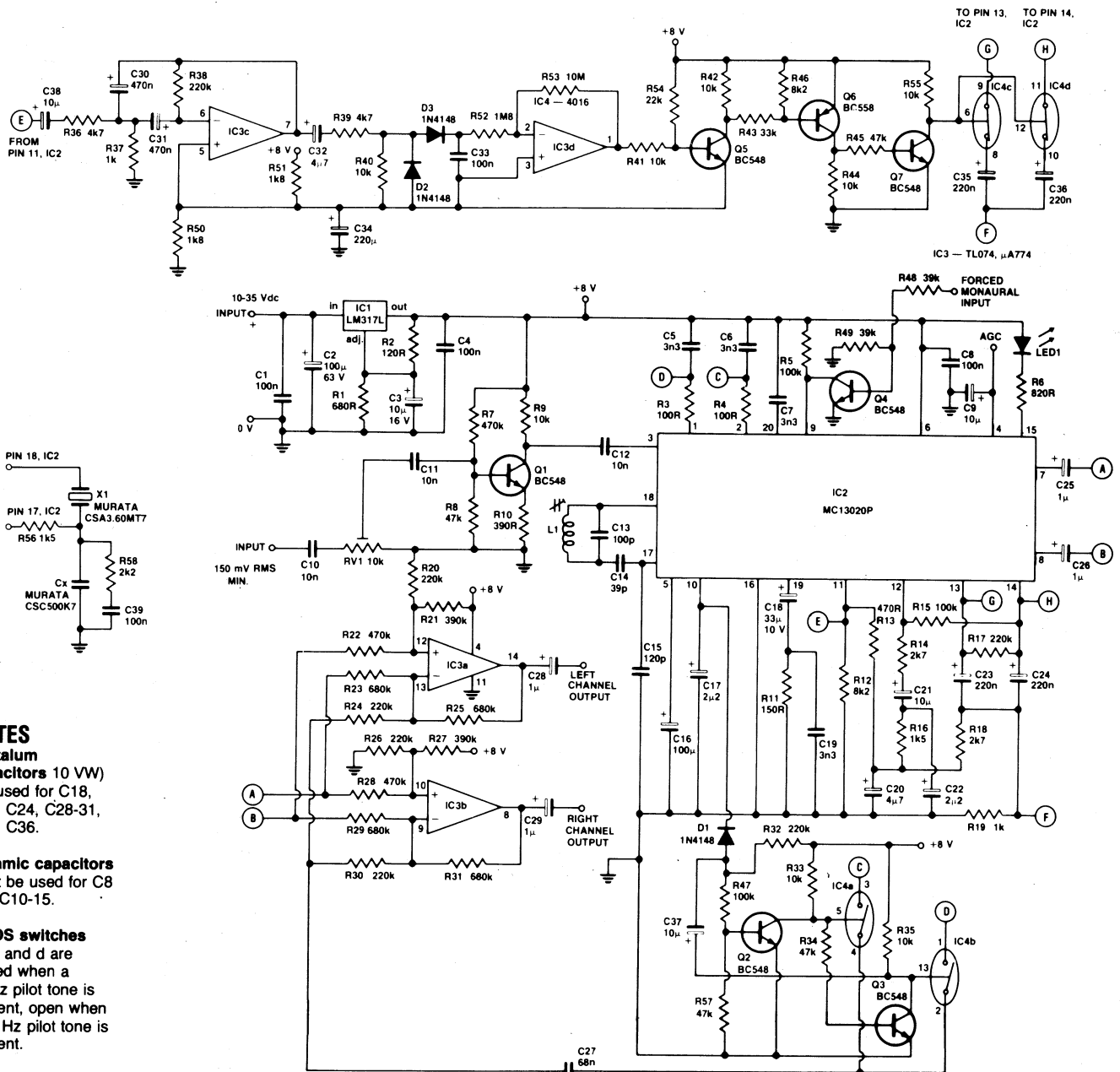

## NOTES

**Tantalum capacitors** 10 WV are used for C18, C23, C24, C28-31, C35, C36.

**Ceramic capacitors** must be used for C8 and C10-15.

**CMOS switches** IC4c and d are closed when a 25 Hz pilot tone is present, open when a 55 Hz pilot tone is present.

## THE MOTOROLA MC13020P C-QUAM AM STEREO DECODER CHIP

This device is a complete one-chip AM stereo decoding and pilot tone detection system. It employs fullwave envelope signal detection at all times for the L + R signal (giving compatible mono AM operation), and decodes L - R signals only when a valid stereo signal is available.

The 25 Hz pilot tone needs to be present to decode the L - R signal. The pilot acquisition time is given as 300 ms for strong signals and this time is extended under noisy conditions to prevent 'falsing'. An internal level detector can be used as an AGC source.

The MC13020P takes the output of the AM tuner's IF amplifier and performs the complete C-QUAM decoding function. In the absence of a good stereo signal, it produces an un-degraded monoaural output from both channels. The L + R mono information delivered to the output always comes from the device's internal envelope detector.

The block diagram of the device here shows what's inside the chip. It first converts the incoming compatible quadrature AM signal to its quadrature components and then decodes these to produce the stereo output channels.

The voltage controlled oscillator (VCO) runs at eight times the input IF frequency. An internal divider provides quadrature (0° and 90°) outputs at the IF frequency for the "I" and "Q" phase detectors. Thus, the VCO works at 3.6 MHz and either a coil-capacitor combination or a low-cost ceramic resonator may be used on the VCO.

The Motorola C-QUAM encoder system multiplies the "I" and "Q" modulating signals by  $\cos \Theta$ . The resulting carrier envelope is  $1 + L + R$ , which is the correct sum signal for mono receivers and for stereo receivers operating in the mono mode.

The quadrature AM conversion is effected in the chip by comparing the output of the envelope detector (Env DET) and the "I" detector (I DET) in the error amp (Err AMP). The provides a  $1/\cos \Theta$  correction factor, which is then multiplied by the incoming signal in the variable gain block (Var Gain). Thus, the output of the variable gain block is the quadrature AM signal, which can then be synchronously detected.

The "I" and "Q" detectors are held at 0° and 90° relative demodulation angles by reference signals from the divided-down VCO.

The output of the "I" detectors is  $1 + L + R$ , with the added benefit (over the envelope detector) of being able to produce a negative output on strong co-channel or noise interference. This is used to tell the Lock circuit to go to mono operation. The output from the "Q" detector is the L - R audio and pilot tone.

The internal PLL corner frequency is set at 8-10 Hz (in lock) by the RC filter on pin 19. An internally controlled fast pull-in is provided, R2 providing slight overdamping while C2 prevents HF instability.

The level detector (Level DET) senses carrier level and provides an optional tuner AGC source. It also operates on the "Q" AGC block to provide a constant amplitude 25 Hz pilot at pin 11. It delivers signal strength information to the pilot decoder.

The Q AGC output drives a low pass filter and an active 25 Hz bandpass filter is coupled to the pilot decoder, pin 14, followed by another low pass filter to the co-channel input, pin 12. If there's a 50% reduction in the 25 Hz pilot level, the system will revert to mono operation.

The co-channel input signal contains any low frequency intercarrier beat notes and, at the selected level, prevents the pilot decode circuit

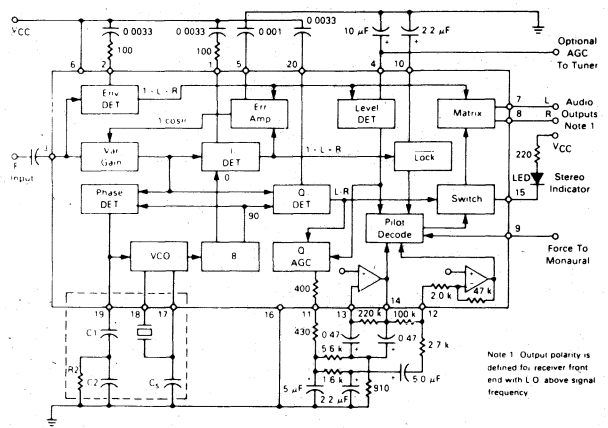

from switching to stereo.

The pilot decoder operates in two modes. Under good signal conditions, the decoder switches to stereo after seven consecutive cycles of the 25 Hz pilot tone (about 300 ms). When signal conditions are bad, the detected interference changes the pilot counter so that 37 consecutive cycles of the pilot are required for stereo operation.

In synthesised tuners, the logic that mutes the audio when tuning can be used to drive pin 9, holding it low. The decoder is forced into mono operation and switches to the short count. When the tuner and the decoder have both locked onto a new station, the pin can be released high, permitting stereo decoding. If no pilot is detected for seven counts, then you're on a mono station and the decoder switches to the long count, reducing the possibility of false stereo triggering ('falsing') due to signal level fluctuation or noise.

If the PLL goes out of lock, or interference is detected by the co-channel circuit before seven cycles are counted, the decoder goes into the long count mode.

The level detector keeps the decoder from going into stereo if the input level drops 10 dB, but will not change the operation of the pilot counter.

Once the decoder's in stereo, it will switch instantly back to mono if either the lock detector on pin 10 goes low or if the carrier level drops below the preset threshold.

In stereo, the co-channel input is disabled and co-channel or other noise is detected by negative excursions of the "I" detector. When these reach 20% co-channel modulation the lock detector puts the system in mono, even though the PLL may be locked. The higher level of co-channel tolerance provides hysteresis to prevent 'chattering' in and out of stereo on a marginal signal.

When all inputs to the Pilot Decode block are correct, and it has completed its count, it turns on the Switch, sending the L - R to the Matrix and dropping pin 15 low (stereo indicator).

may need to bend ~~IC10~~ <sup>C10</sup> aside a little when fitting RV1.

Now wind L1 according to the coil winding details given here. Glue the former to the board with a quick-set glue like 'Super-glue' (take care!). Cut the coil leads to length and tin the ends before soldering them in the pads indicated on the overlay. Place the can over the coil, pushing it right down on the board and, solder the pins to secure it.

If you're using the ceramic resonator, follow the alternate overlay diagram.

Now solder all the pc stakes in place. These provide handy termination for all the off-board connections.

When you think you've got it all finished. Give it a *thorough* check.

### Tuner requirements

Before you can install your project, perhaps even before you build it, there are a number of matters to consider about the tuner or receiver in which it may be installed.

You can't install an AM stereo decoder in just any AM radio or tuner. Not all types are suitable owing to certain design or construction limitations that adversely affect decoder operation. Obviously, it's impossible

for us to list the 'good' ones by make and model number. For a start, we haven't tried them all (... nor are we likely to). But we can give you some general hints so you can avoid the 'unlikelies' and, making an informed choice, ensure success.

If you're thinking of converting grandfather's old Radiola three-band *valve* receiver in the gigantic console wood veneer cabinet — forget it. The same goes for 'Little Nipper' valve mantle sets or their ilk. Resign yourself to the fact that his project will have to be solid state all the way.

However, modern pocket transistor sets, clock radios, many portables etc, generally won't meet the requirements either. They generally have poor oscillator stability, narrow IF bandwidths and insufficient sensitivity (for this application). Units with in-built speakers will generally be a no-no.

In general, the receiver or tuner requirements are:

- a stable, 'clean' local oscillator which is above the signal frequency.
- a wide IF bandwidth that gives an audio output bandwidth from its envelope detector of at least 5 kHz, and preferably

twice that. The IF bandpass characteristic should be reasonably flat.

- good sensitivity. This generally means it should have an RF amplifier stage.
- an AGC system that maintains a generally constant IF output with widely varying signal strengths from stations. It should have a slow enough response (in the order of a second or more) so that distortion is not introduced in the 25 Hz pilot tone.
- an IF output to the envelope detector of at least 100 mV RMS, preferably 200-300 mV.

Many hi-fi tuners and integrated receivers on the market will meet these requirements. Those having synthesiser front ends are far and away the best though their PLL circuitry can sometimes interfere with the decoders. Mechanically tuned receivers can experience microphony on the local oscillator, but not all show the problem. Those with sturdy mechanical construction should not suffer in this regard. Of all the requirements, the local oscillator and IF bandwidth

## HOW IT WORKS — ETI-739

Circuit operation hinges around the Motorola MC13020P C-QUAM stereo decoder chip. The general operation of this device is explained in a separate panel. Let's take an overall look at the circuit.

The IF input is buffered and amplified by Q1, a simple wideband common emitter stage. Emitter degeneration feedback is employed via the unbypassed emitter resistor, R10, ensuring stable gain and wide bandwidth. The input is capacitively coupled via C10. RV1 provides input level adjustment as the IF output of different receivers will differ widely.

Dual-system reception necessitates compromising the operation of the decoder, IC2, somewhat, but this is partially corrected by the extra circuitry. The synchronous phase detection function of the MC13020P is employed in receiving both systems, but the Harris system requires extra audio matrixing. The MC13020P is arranged to automatically switch between systems by detecting the presence of the pilot tone, differentiating between the 25 Hz (Motorola) and 55 Hz (Harris) pilot tone frequencies and then altering the operation of the decoder by switching in extra components.

This is accomplished by the Pilot Tone Detector circuitry comprising IC3c and d, diodes, D2 and D3 plus transistors, Q5-6-7 and two CMOS switches, IC3c and d, and the associated circuitry.

So that the audio output still switches to mono when a signal cannot be 'locked' by the decoder, circuitry involving Q2, Q3 and two CMOS switches provides output from the envelope detector of IC2, passing this to the output matrixing op-amps, IC3a, and b. When a stereo signal is locked by the decoder, this same circuitry provides a matrixing signal to these op-amps from the "I" detector during reception of both Harris and Motorola transmissions.

The VCO in IC2 can be controlled either by an LC circuit (L1-C13) or a ceramic resonator (as shown on the supplementary circuit).

Either can be used and the pc board overlays show how to implement them. Resistor R56 "de-Qs" the ceramic resonator, providing a wider pull-in range for the VCO. Capacitor Cx provides temperature compensation for the ceramic resonator. These two items from Murata come as a pair. They are imported and distributed by IRH Components, Sydney, who kindly supplied samples.

Transistor Q4 buffers the 'force to mono' input of IC2, pin 9. To force mono operation, the base of Q4 should be held high (via the FORCED MONAURAL INPUT).

The LED (LED1) indicates stereo operation. A three-terminal regulator, IC1, generates an 8 V supply rail and prevents supply input variations from affecting the decoder's performance.

### PILOT TONE DETECTOR

The purpose of the pilot tone detector is to place the decoder in the Harris mode when a 55 Hz pilot tone is detected (e.g. from 2SM, 3XY, etc) and in the Motorola mode when a 25 Hz pilot tone is detected (e.g. from 2WS, 3 AK etc).

The circuitry consists of a 25 Hz bandpass filter (IC3c and surrounding components), followed by a half-wave voltage-doubler rectifier (D2, D3, C33). Then follows an inverting dc amplifier (IC3d) and a dc switch (Q5, Q6, Q7) to operate two CMOS switches (IC4c and d).

A sample of the pilot tone is derived from the AGCd output of IC2 (pin 11) at 'E'.

When a Motorola station is being received by the tuner/receiver, the 25 Hz pilot tone is passed by IC3c and rectified by D2-D3. This charges C33 and the output of IC3d (pin 1) will go to around -0.7 V (referred to the half-supply rail on pins 3 & 5 of IC3 and emitter of Q5). Resistors R52 and R53 are high values to avoid loading the rectifier.

The output of IC3d turns Q5 off, and thus Q6 and Q7 are off, too. The collector of Q7 goes high, closing the two CMOS switches, IC4c and d. This places C35 and C36 in parallel with pins 13 and 14 of IC2. These are the

decoder's pilot filter pins and thus it is set to respond to the 25 Hz pilot tone in order to decode the Motorola signal.

When a Harris station is being received, the 25 Hz bandpass filter will not respond to the 55 Hz pilot tone and thus there will be no output at pin 7 of IC3c. Therefore, the output of IC3d will go to zero (with respect to the half-supply rail) and the base of Q5 will be biased on by R54. This will turn on Q6 and Q7, opening the CMOS switches, IC4c and d. This disconnects C35 and C36 from pins 13 and 14 of IC2, allowing its pilot decoder to respond to the 55 Hz pilot tone so it will decode the Harris signal.

### DECODING

The Error Amp in IC2 is disabled by the 100µF capacitor (C16) on pin 5 of the decoder. This change results in the L and R outputs (pins 7 and 8) putting out envelope-plus-Q and envelope-minus-Q signals. The difference between pins 7 and 8 is the Q or L-R channel.

The matrixing op-amps, IC3a and b, perform the differencing. The operation requires a proper L+R signal. Both in-phase (I) and envelope signal are available at 'D' and 'C', respectively. When the decoder is locked, pin 10 goes high. The cathode of D1 is then positive with respect to its anode and the base of Q2 is biased on via R32-R47. Thus, the collector of Q2 goes low and the CMOS switch IC4a is held open. But the base of Q3 will be low and thus its collector will be high (Q4 off). This will turn on the CMOS switch IC4b and the "I" signal on 'D' will be passed via C27 to the matrixing op-amps which will then produce the L and R signals at their outputs.

If the decoder goes out of lock, pin 10 goes low, clamping the base of Q2 low via D1. Thus Q2 turns off and Q3 turns on. Therefore, IC4b will turn off and IC4a will turn on. This will pass the envelope detector output (from 'C') to the matrixing op-amps via C27, producing a monaural output in both channels. When tuning between stations, this prevents annoying whistles being heard.

Operation is similar for Motorola decoding.

characteristics are the most important.

One way to test the local oscillator of a tuner or receiver is to listen to it on a general coverage ('communications') receiver. Tune the radio intended for conversion to the high frequency end of the broadcast band (around 1600 kHz) and look for the local oscillator signal on the general coverage receiver around 2050 kHz.

You can generally get a good signal by attaching a few hundred millimetres of wire to the antenna terminal of each receiver and loosely twisting them together.

The audio note you pick up should sound clear and pure, without trace of warbling sounds or pitch variations, especially when you touch or knock the AM tuner's case. A 'rough' note generally means the AM tuner's local oscillator is hum modulated.

Set the AM tuner to a strong local station. Find the local oscillator signal again and see that it does not vary with the station's modulation.

If any of these symptoms show up, the unit's not a candidate for adding-on the stereo decoder.

Unless you can measure the tuner's IF characteristics, you'll have to trust its handbook specifications and 'suck it and see'.

## Installation

The first commandment of installation is — 'know thy tuner'. This means, you'll have to

locate the tuner's last IF stage. Some have a transistor, some have an IC output at this point. Generally, the last stage has a tuned transformer coupling to the envelope detector (usually a diode). Locate the diode detector and remove it. The IF output transformer secondary may be tuned or untuned. Generally though, you'll find enough signal here to drive the decoder.

This point should be coupled to the decoder board via a short length of low capacitance screened cable. Ground the shield only at the decoder end. Set RV1 at about half rotation.

The FORCED MONO input and the AGC line can be ignored for the moment, along with the LED OUTPUT.

The 0 V lead should be securely earthed to the tuner's chassis or board ground track. Shielded leads should be used for the LEFT and RIGHT outputs. A point marked GND, between these two pads on the board, provides a suitable termination for the shields. Hook-up a suitable dc power supply.

Our prototype was successfully installed in a Teac T-515 tuner.

## Setup and alignment

If you have an oscilloscope (at least 15 MHz bandwidth) or a frequency counter, you can set the VCO on frequency quite easily. Just loosely couple into pin 17 of IC2 and set the

coil slug, using a plastic aligning tool, to obtain a frequency close to 3.6 MHz (eight times the IF frequency — 3.60 MHz for 450 kHz, 3.64 MHz for 455 kHz).

This is unnecessary if you're using the ceramic resonator.

If you don't have either of these tools, proceed as follows. First lift the cathode end of D1. Switch everything on and tune the receiver to any station (mono or stereo). With a plastic alignment tool, adjust the slug in L1 until you hear a heterodyne note in the tuner (a whistle). Keep adjusting the slug, bringing the heterodyne down in pitch to 'zero beat'. Keep adjusting the slug in the same direction until you hear a second heterodyne.

Best alignment is then achieved by tuning the slug half way between these two 'beat notes'. This can be accomplished by counting the number of turns between beat notes, halving the number and turning the slug black by that amount.

Restore D1.

Tune around the dial and check the decoder's performance on known stereo stations transmitting Harris or Motorola stereo signals. Check that the stereo indicator, LED1, lights when a stereo signal is tuned in.

## Problems and pointers

Once alignment is achieved and stereo

# COMPONENT LAYOUT

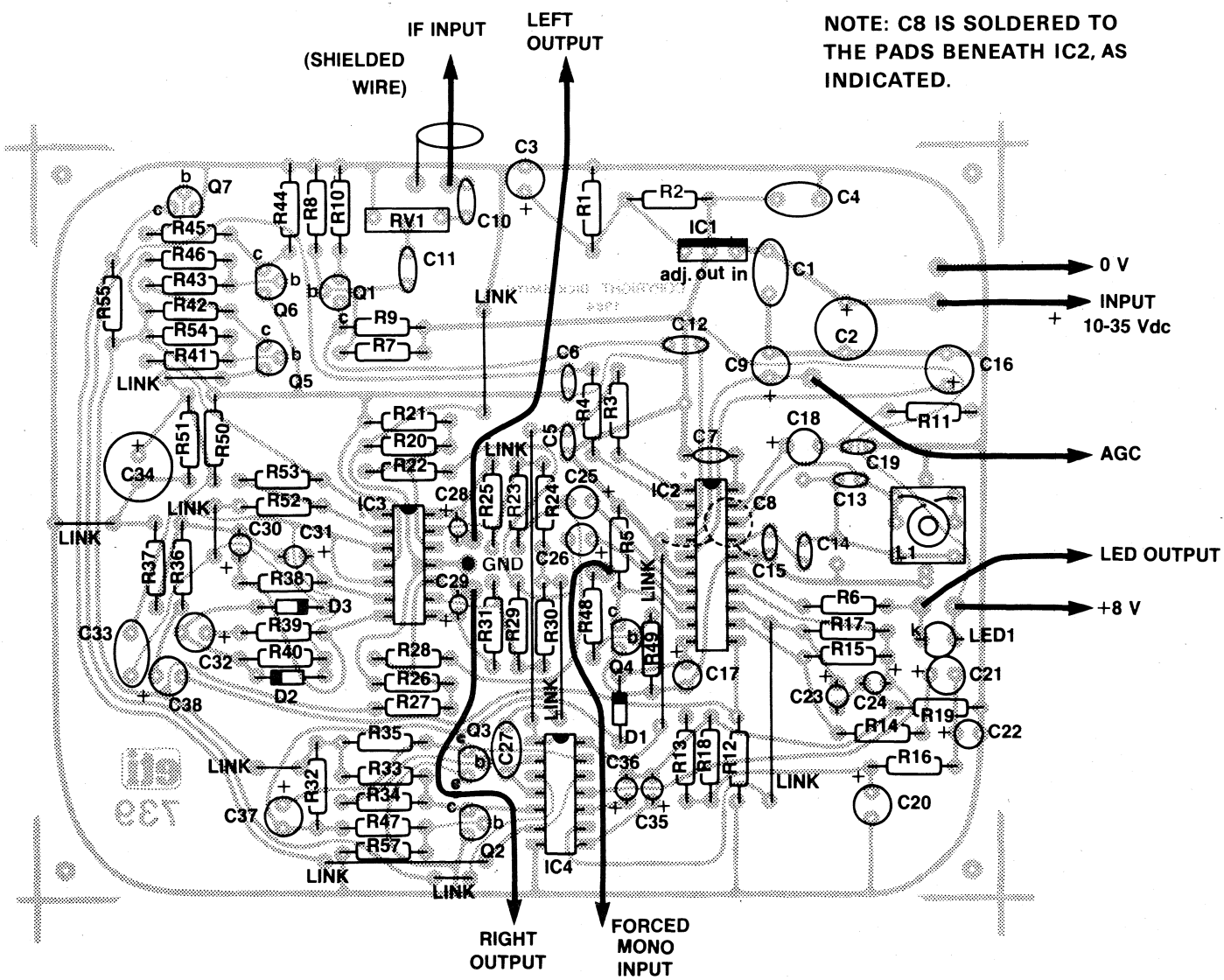

## COMPONENT PINOUTS

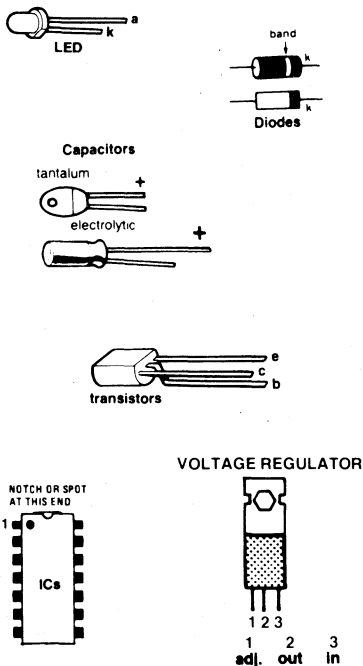

## COMPONENT LAYOUT FOR CERAMIC RESONATOR

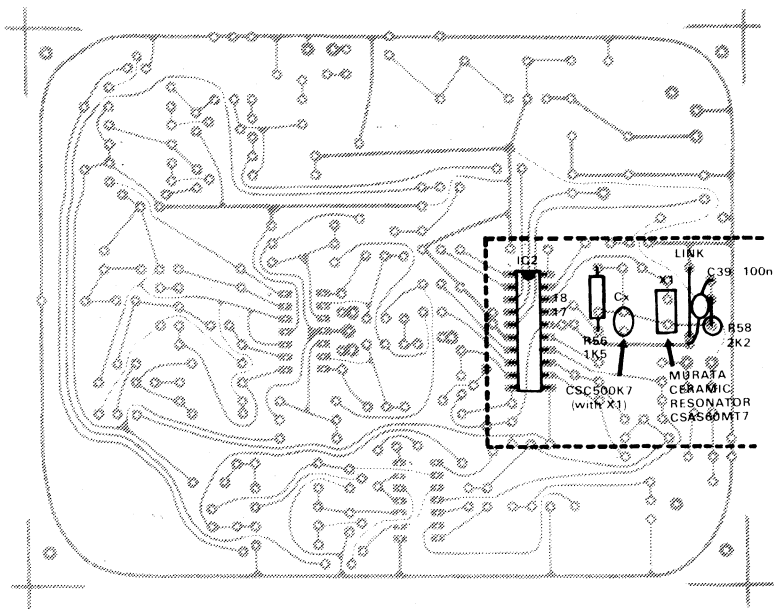

## PARTS LIST

### RESISTORS

Constructors please note that all resistors are 1/4W unless specified.

2x	100R Resistor ( <del>R3, R4</del> )	<input type="checkbox"/>
1x	120R Resistor ( <del>R2</del> )	<input type="checkbox"/>
1x	150R Resistor ( <del>R11</del> )	<input type="checkbox"/>
1x	390R Resistor ( <del>R10</del> )	<input type="checkbox"/>
1x	470R Resistor (R13)	<input type="checkbox"/>
1x	680R Resistor ( <del>R1</del> )	<input type="checkbox"/>
1x	820R Resistor ( <del>R0</del> )	<input type="checkbox"/>
2x	1K Resistor ( <del>R15, R37</del> )	<input type="checkbox"/>
1x	1.5K Resistor ( <del>R16</del> )	<input type="checkbox"/>
2x	1.8K Resistor ( <del>R50, R51</del> )	<input type="checkbox"/>
2x	2.7K Resistor ( <del>R14, R18</del> )	<input type="checkbox"/>
2x	4.7K Resistor ( <del>R36, R39</del> )	<input type="checkbox"/>
2x	8.2K Resistor (R12, <del>R40</del> )	<input type="checkbox"/>
8x	10K Resistor ( <del>R0, R33, R35, R40, R41, R42, R44, R56</del> )	<input type="checkbox"/>
1x	22K Resistor ( <del>R54</del> )	<input type="checkbox"/>
1x	33K Resistor ( <del>R43</del> )	<input type="checkbox"/>
2x	39K Resistor ( <del>R48, R49</del> )	<input type="checkbox"/>
4x	47K Resistor ( <del>R0, R34, R45, R57</del> )	<input type="checkbox"/>
3x	100K Resistor ( <del>R5, R15, R47</del> )	<input type="checkbox"/>
7x	220K Resistor ( <del>R17, R20, R24, R26, R30, R32, R38</del> )	<input type="checkbox"/>
2x	390K Resistor ( <del>R21, R27</del> )	<input type="checkbox"/>
3x	470K Resistor ( <del>R7, R22, R28</del> )	<input type="checkbox"/>
4x	680K Resistor ( <del>R23, R25, R29, R31</del> )	<input type="checkbox"/>
1x	1.8M Resistor ( <del>R52</del> )	<input type="checkbox"/>
1x	10M Resistor ( <del>R53</del> )	<input type="checkbox"/>
1x	10K Trimpot (RV1)	<input type="checkbox"/>

### CAPACITORS

4x	0.0033uF Greencap ( <del>C5, C6, C7, C19</del> )	<input type="checkbox"/>
1x	0.068uF Greencap ( <del>C27</del> )	<input type="checkbox"/>
3x	0.1uF Greencap ( <del>C1, C4, C33</del> )	<input type="checkbox"/>
1x	39pF Ceramic ( <del>C14</del> )	<input type="checkbox"/>
1x	100pF Ceramic (C13)	<input type="checkbox"/>
1x	120pF Ceramic ( <del>C15</del> )	<input type="checkbox"/>
3x	0.01uF Ceramic ( <del>C10, C11, C12</del> )	<input type="checkbox"/>

1x	0.1uF Ceramic (C8)	<input type="checkbox"/>
1x	100uF Axial Electro (C2)	<input type="checkbox"/>
2x	1uF Electro ( <del>C25, C26</del> )	<input type="checkbox"/>
2x	2.2uF Electro ( <del>C17, C22</del> )	<input type="checkbox"/>
2x	4.7uF Electro ( <del>C20, C32</del> )	<input type="checkbox"/>
5x	10uF Electro ( <del>C3, C9, C21, C37, C38</del> )	<input type="checkbox"/>
1x	100uF Electro (C16)	<input type="checkbox"/>
1x	220uF Electro ( <del>C34</del> )	<input type="checkbox"/>
4x	0.22uF Tantalum ( <del>C23, C24, C35, C36</del> )	<input type="checkbox"/>
2x	0.47uF Tantalum ( <del>C30, C31</del> )	<input type="checkbox"/>
2x	1uF Tantalum ( <del>C28, C29</del> )	<input type="checkbox"/>
1x	33uF Tantalum ( <del>C18</del> )	<input type="checkbox"/>

### SEMICONDUCTORS

6x	BC548 Transistor (Q1-Q5, Q7)	<input type="checkbox"/>
1x	BC558 Transistor (Q6)	<input type="checkbox"/>
3x	1N4148 Diode (D1, D2, D3)	<input type="checkbox"/>
1x	Red LED (LED1)	<input type="checkbox"/>
1x	4016 IC (IC4)	<input type="checkbox"/>
1x	TL074 IC (IC3)	<input type="checkbox"/>
1x	LM317/T IC (IC1)	<input type="checkbox"/>
1x	MC13020P IC (IC2)	<input type="checkbox"/>
1x	Coil Former, Former Base, Can, Ferrite Core (L1)	<input type="checkbox"/>

### MISCELLANEOUS

PCB pins, enamel copper wire, solder, hookup wire, shielded cable, tinned copper wire, PCB

Constructors please note that if you are using the ceramic resonator the parts listed below should be mounted onto the board. Please refer to the component layout on Page 6 for mounting details. THESE PARTS ARE NOT SUPPLIED IN THE KIT.

1x	1.5K Resistor (R56)	<input type="checkbox"/>
1x	2.2K Resistor (R58)	<input type="checkbox"/>
1x	0.1uF Ceramic (C39)	<input type="checkbox"/>
1x	CSC500K7, Murata (Cx)	<input type="checkbox"/>
1x	CSA3.60MT7 Murata Resonator (X1)	<input type="checkbox"/>

operation does not seem to be happening, it may be a result of too small an IF signal level to the input of IC2. Try turning up RV1 to increase the signal input. This is best done on a Motorola system station. If you have an RF probe for your multimeter, or a CRO, check the level at pin 3 of IC2 and see that you're getting at least 150-200 mV RMS there. If you've got this signal level there but the stereo indicator still does not light, there could be a pilot tone level problem.

Try increasing the value of C21. You can bump it up to as much as 47µ, if you wish, to lift this level. The same result can be achieved by lowering the value of R14. The pilot tone level at pin 14 of IC2 should be the order of 400 to 600 mV peak-to-peak.

If you want to use the existing stereo indi-

### COIL WINDING

If you're using the coil L1, it is wound as follows. Take the 722/1 former and wind 38 turns of 36 B&S enamelled copper wire on it, laying the turns close together. Wind it neatly up the former, not jumbled. It doesn't matter whether you wind it clockwise or anti-clockwise.

You can secure the start of the winding with a dab of instant-setting glue, like 'Superglue' (but be careful with it). When you've finished the winding, secure it with a length of sticky tape wrapped around the winding.

Insert the slug in the former and screw it all the way in. Take it gently so that you don't break it. They're fragile.

cator LED on your tuner, proceed with caution. Although pin 15 of IC2 is capable of sinking 50 mA, the LED current should be limited to a maximum of 10 mA. Too much current drawn by the indicator causes a loading effect on the IC which creates a phase disturbance that knocks the decoder out of lock. The decoding process starts all over again and when the lock condition brings on the stereo LED the excessive current knocks off the stereo operation once more and the whole process repeats itself.

All you end up with is a flashing LED and mono output.

Under noisy conditions, the receiver may be tuned with the FORCED MONO input temporarily held high until the station's tuned in. Upon release, the decoder should find it easier to lock into stereo operation.

Happy stereo listening!

K-6320 AM STEREO DECODER.

Please note that L1 coil termination shown in the instructions is incorrect. Please refer to the diagram below for correct coil termination.

