



TECHNICAL DATA

AN EXCLUSIVE RADIO SHACK SERVICE TO THE EXPERIMENTER

SN76495 COMPLEX SOUND GENERATOR

DESCRIPTION

The SN76495 Complex Sound Generator Integrated Circuit combines both analog (linear) and digital (I²L) circuitry. It consists of special-effects noises, tones, low frequency based sounds or a combination of these. By using various external components and by controlling the input logic, you can create a wide variety of sounds. The SN76495 can be used in any application that requires audio feedback to the operator, including entertainment equipment — such as arcade or home video games, pin-ball games, toys, alarms; or industrial equipment (indicators, controls, etc.).

Operation is from a 7.5 to 10.5-volt supply applied to a built-in regulator through the Vcc terminal; in which case, a regulated five volts is available from the Vreg terminal to power a small amount of external circuitry, or to provide a high-logic-level voltage to logic inputs.

FEATURES:

- Generates Noise, Tone or Low-Frequency-Based Sounds, or a Combination of These
- Allows Custom Sounds to be Created Easily
- Low Power Requirements
- Allows Multiple-Sound Systems
- Compatible With Microprocessor Systems
- On Board 125mW Audio Amplifier

DUAL-IN-LINE PACKAGE (TOP VIEW)

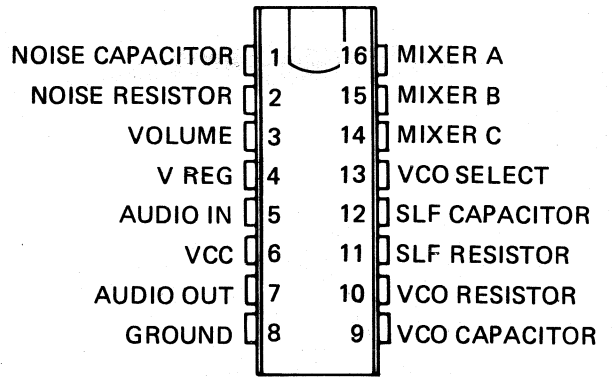

ABSOLUTE MAXIMUM RATINGS AT Ta=25°C (unless otherwise specified)

Supply Voltage, Vcc	12.0V
Input Voltage: Logic Input	12.0V
Capacitor Input	5.0V
Resistor Input	5.0V
Operating Free-Air Temperature Range	0°C to 70°C
Storage Temperature Range	-65°C to 150°C

RECOMMENDED OPERATING CONDITIONS

	MIN	NOM	MAX	UNITS
Supply Voltage, Vcc	7.5	9.0	10.5	Volts
Operating Free-Air Temp		25		°C
Amplifier Load AC Coupled	8.0			Ohms

Note 1: All voltage values are with respect to the ground terminal. (pin 8)

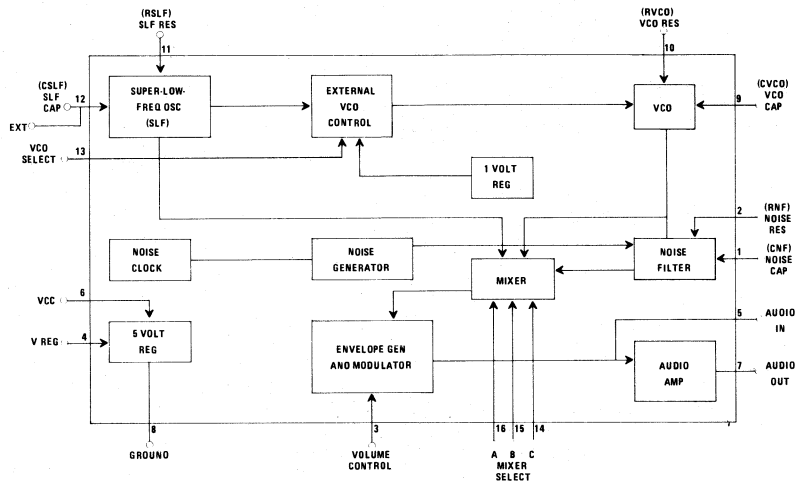

Figure 1. SN76495 BLOCK DIAGRAM

CUSTOM PACKAGED IN U.S.A. BY RADIO SHACK A DIVISION OF TANDY CORPORATION

OPERATION

1. SUPER LOW FREQUENCY OSCILLATOR (SLF)

The SLF is normally operated in the range of 0.1 to 30 Hz, but will operate up to 20 kHz. The frequency is determined by two external components, the SLF control resistor (Rslf) pin 11 and capacitor (Cslf) at pin 12 according to the following equation:

Equation 1: (@Vreg = 5V)

$$\text{SLF Frequency (Hz)} = \frac{0.66}{(9k \text{ ohms} + R_{slf}) \times C_{slf}}$$

The SLF feeds a 50% duty cycle square wave to the "mixer"; it also feeds a triangular wave to the external VCO of SLF select logic, where, if VCO select (pin 13) is at a low logic level (ground), it is fed through to the VCO to modulate the frequency of that oscillator. (See further explanation below).

2. VOLTAGE CONTROLLED OSCILLATOR (VCO)

The VCO produces a tone output whose frequency is dependent upon the voltage at the input of the VCO. This controlling voltage may be either the SLF output described above; an internal voltage producing a constant tone; or externally, by placing a voltage on the SLF capacitor, pin 12. The higher the voltage applied to the VCO, the lower the frequency of the VCO output. The selection of the control modes (external, pin 13, internal SLF) is via the binary logic on pin 13 according to the following table:

Pin 13	Control Mode
0	External (pin 12)
1	Internal (SLF)

Table 1: VCO Control Mode Selection

The first mode, VCO controlled by SLF, is selected by placing the VCO select pin low. The triangular voltage from the SLF is applied to the VCO and varies the voltage level applied to the VCO capacitor connected between pin 9 and ground. As the applied voltage from the SLF oscillator increases, the VCO frequency decreases and conversely, as the voltage decreases the VCO frequency increases, resulting in a frequency modulated output. The minimum VCO frequency (in Hertz) which can be modulated by the SLF oscillator can be found by the equation:

Equation 2: (@Vreg = 5V)

$$\text{Minimum VCO Freq. (Hz)} = \frac{0.60}{(9k \text{ ohms} + R_{VCO}) \times C_{VCO}}$$

The frequency range of the VCO is internally determined at an approximate ratio of 10:1, so that maximum frequency of the VCO will be approximately ten times the minimum frequency that is determined by the external components R_{VCO} and C_{VCO}.

The second method of supplying a control voltage for the VCO is to use an internal voltage preset at 1 volt. This mode, is selected by taking VCO select to a high level. In this mode, the VCO puts out a constant tone determined by CVCO and R_{VCO} in this relationship:

Equation 3: (@Vreg = 5V)

$$f_{VCO} \text{ (Hz)} = \frac{1.45}{(R_{VCO} + 9k \text{ ohms}) \times C_{VCO} \times 0.9V}$$

A third method of controlling the voltage to the VCO is to apply the controlling voltage (V_{ext}) to the SLF capacitor pin. This voltage level (0 to 2.30 volts) will determine the output frequency of the VCO. Output frequency in this mode is determined by this relationship:

Equation 4: (@Vreg = 5V)

$$f_{VCO} \text{ (Hz)} = \frac{1.45}{(R_{VCO} + 9k \text{ ohm}) \times C_{VCO} \times (V_{ext} - 0.1V)}$$

3. MIXER

The mixer logic selects one, or a combination of the inputs from the generators and feeds the output to the amplifier via the Envelope Generator and modulator. The mixer performs a logical AND function on these sounds; therefore, the output of the mixer is not a combination of simultaneous sounds. The output of the mixer is determined by the logic levels at the mixer select inputs as shown in Table 1 below:

TABLE 1

MIXER SELECT INPUT			MIXER OUTPUT
A (PIN 16)	B (PIN 15)	C (PIN 14)	
0	0	0	VCO
1	0	0	SLF
0	1	0	NOISE
1	1	0	VCO/NOISE
0	0	1	SLF/NOISE
1	0	1	SLF/VCO/NOISE
0	1	1	SLF/VCO
1	1	1	INHIBIT

1 = HIGH LEVEL

0 = LOW LEVEL OR OPEN

Figure 2 is an example of how two signals would be combined by the mixer according to the logical AND function with the mixer select times set for SLF/noise (C input high, A and B inputs low).

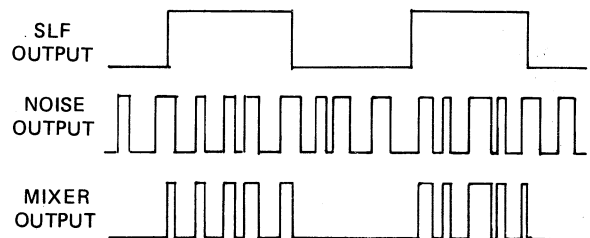

Figure 2

To obtain two sounds simultaneously (e.g., car engine and siren or steam engine and whistle), multiplexing is required. The multiplexing is accomplished by switching the mixer select lines at a sufficiently rapid rate that the two sounds seem to occur at the same time. The frequency of the multiplexing should be above the human hearing range. A multiplexing drive signal with a 50% duty cycle is required to provide equal amplitudes for both sound functions.

4. VOLUME

Output volume from the SN76495 can be controlled by varying a voltage level on pin 3. This voltage level should range from 3.5 volts, for maximum volume, to .4 volts or below for no output. **Under no circumstances should this pin be taken above 5 volts or below 0 volts. Voltages outside of this range could damage the unit.**

5. NOISE GENERATOR/FILTER

The noise generator produces pseudo-random white noise that passes through the noise filter before being applied to the mixer. The variable-band-width low-pass filter has its cutoff point defined by the noise filter control resistor (Rnf) at pin 2 and the noise filter control capacitor (Cnf) at pin 1 according to the following equation:

Equation 5: (@Vreg = 5V)

$$f_{\text{cutoff}} (\text{Hz}) = \frac{0.43}{(9\text{k ohm} + R_{\text{nf}}) \times C_{\text{nf}}}$$

6. OUTPUT AMPLIFIER

The output (audio) amplifier is contained entirely on chip. The amplifier operates in a transimpedance mode and has a push-pull output capable of delivering 125 mA into a capacitively coupled 8 ohm load. This produces a two volt peak to peak output signal. The amplifier input (pin 5) can be used to sum several external current signals. If the signals are composed of a varying voltage they must first be converted to current signals. This can be accomplished by using a resistor in series between the external source and the input (pin 5). The relationship of this resistor value (Rseries) to the external signal voltage (Vmax) is given by the following equation:

Equation 6: (@Vreg = 5V)

$$-100\mu\text{A} < V_{\text{max}} - \frac{3\text{V}}{R_{\text{series}}} < 100\mu\text{A}$$

Gain of the amplifier can be controlled by adding a resistor in parallel to the internal 10 Kohm feedback resistor. This will decrease gain and allow a larger input current.

7. REGULATOR

The circuit will operate from a single supply (pin 6). An internal 5 volt regulator allows the use of 7.5 volt to 10.5 volt unregulated supply applied to Vcc (pin 6) and in addition to supplying power for the chip, the internal regulator will provide a 5 volt regulated supply of up to 5 mA from Vreg (pin 4) for use outside the integrated circuit.

DESIGN SEQUENCE FOR DEVELOPING COMPLEX SOUND

An approach to designing custom complex sounds will be illustrated and discussed in this section. These steps may vary depending on your particular applications for the IC.

The first step is to build a "sound demonstrator box" similar to the one shown below. This is a time-saving step and will aid in analyzing and understanding each section of the chip, help in determining

what sounds are desired and in determining the component values to obtain those sounds. The demonstrator box typically requires a couple of days for a technician to build. If portable operation is desired, a 9-volt battery may be used for a power source.

The next step is to check out each section of the IC using the demonstrator box.

SN 76495 DEMO/TEST BOX

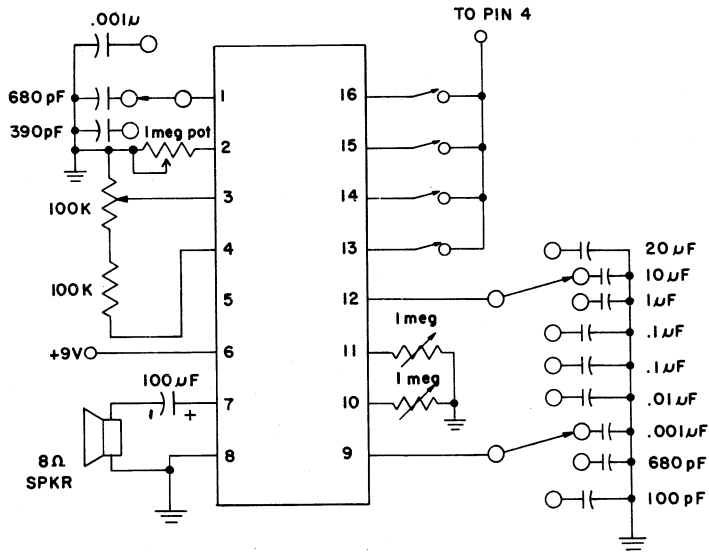

NEGATIVE TERMINAL OF THE BATTERY CONNECTS TO GROUND

FUNCTION SUMMARY			
DESCRIPTION	PIN NO.	LIMIT	FUNCTION
SLF Control Resistor (Rslf)	11	$I_{Rslf}=250\mu A$ (See Note 4)	$I_{Rslf}=2.75\text{Volts}/(9\text{Kohm}+Rslf)$
SLF Control Capacitor (Cslf)	12		$fslf=.66/(9\text{Kohm}+Rslf)\times Cslf$
VCO Select	13	9V Maximum	Input Low(Note 5)=VCO Controlled by SLF Input High(Note 5)=Internal Voltage Controls VCO
VCO Control Resistor (RVCO)	10	$I_{RVCO}=250\mu A$ max.	$I_{RVO}=2.75\text{Volts}/(9\text{Kohm}+RVCO)$
VCO Control Capacitor (CVCO)	9		$fslf=.60/(9\text{Kohm}+RVCO)\times CVCO$
VCO External Control	12	0 to 2.30 Volts	Increase in Voltage Decreases VCO Frequency
Noise Filter Resistor (2Rnf)	2	$I_{Rnf}=250\mu A$ max.	Low Pass Filter
Noise Filter Capacitor (Cnf)	1		$I_{Rnf}=2.75\text{Volts}/(9\text{Kohm}+Rnf)$ $f_{cutoff}=.43/(9\text{Kohm}+Rnf)\times Cnf$
Mixer Select A	16	9V Maximum	Selects one or a combination of generator outputs. Mixer output is a logic "AND" function of mixer inputs.
Mixer Select B	15	9V Maximum	
Mixer Select C	14	9V Maximum	
Volume	3	.4 to 3.5 Volts	Controls output volume. 3.5 volts give maximum output. Minimum voltage (Off) at .4 volts.
Amplifier Input	5		Can be used to sum externally applied signals. Amplifier output is push-pull and is designed to swing 2 volts peak to peak when driven internally by sound generators.
Amplifier Output	7		

Note 4: To reduce sound variations from chip to chip, it is suggested that control resistors be large in value to negate the effects of the internal current protect resistors. This also reduces the value of the control capacitors.

Note 5: As defined by V_{il} and V_{ih} in electrical specification.

Step six requires a breadboard of the circuit. Then make any necessary adjustments to the component values.

Step seven is used when several sounds that you have developed (through steps three to five) need to be combined. Compare each individual sound schematic produced in step five. Select all common components on each circuit and draw this on another IC pinout copy. Then determine if any differing values may be compromised to the same value as that used in another sound. For example, if a

gun-shot was determined to have a certain set of RC one-shot values, and a ricochet had another set, then could there be a compromise between the two which would make one set common to both? Decide on the type of switching logic you will need to switch between sounds, plus any component additions and add to this drawing.

In step eight, this preliminary system should be bread-boarded. Then each sound should be adjusted until that sound is satisfactory.

TYPICAL APPLICATIONS

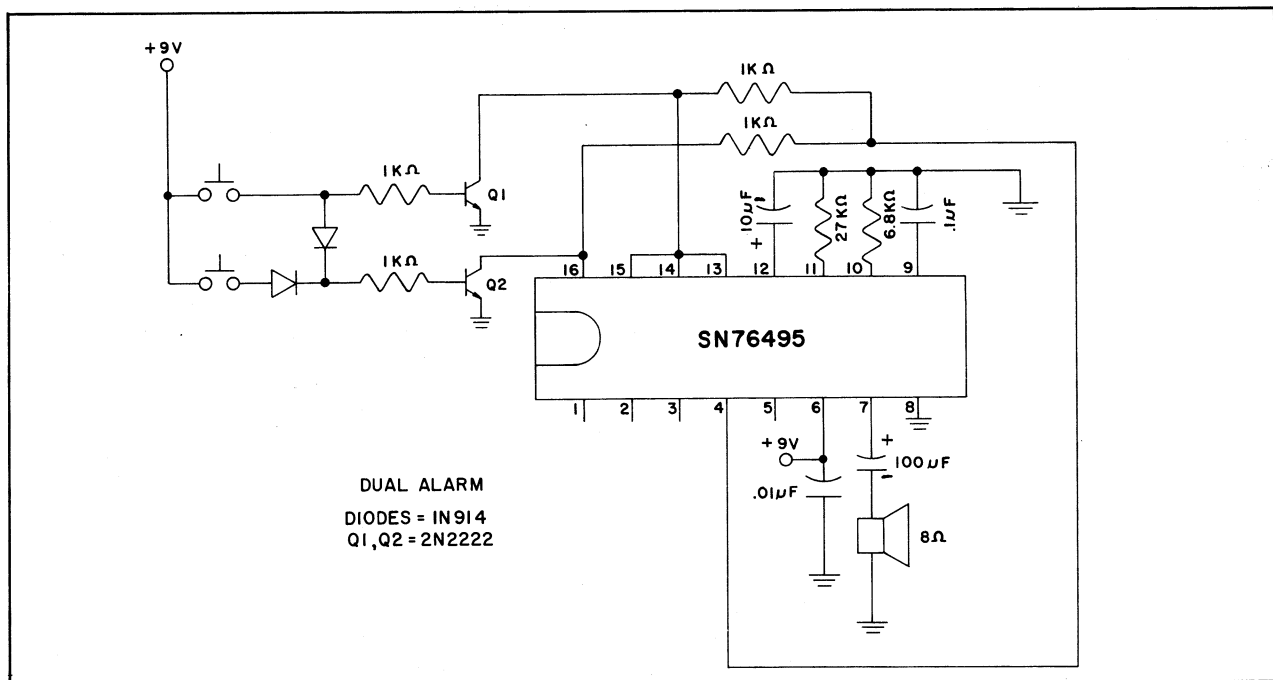
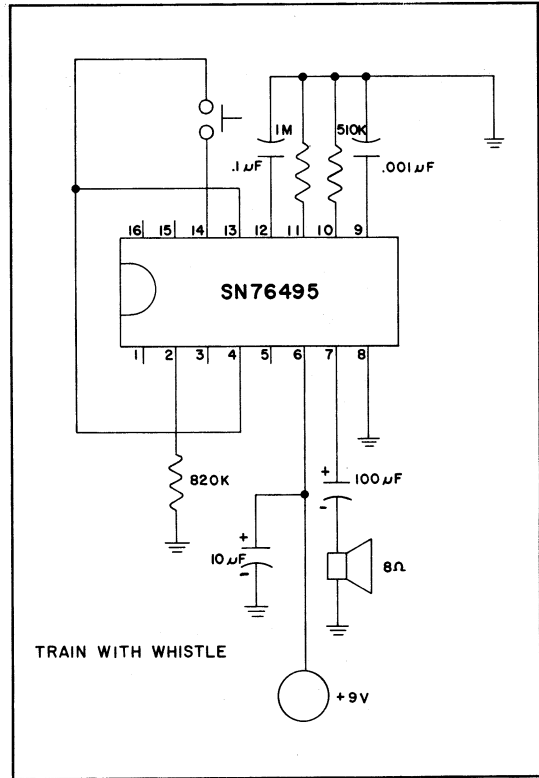
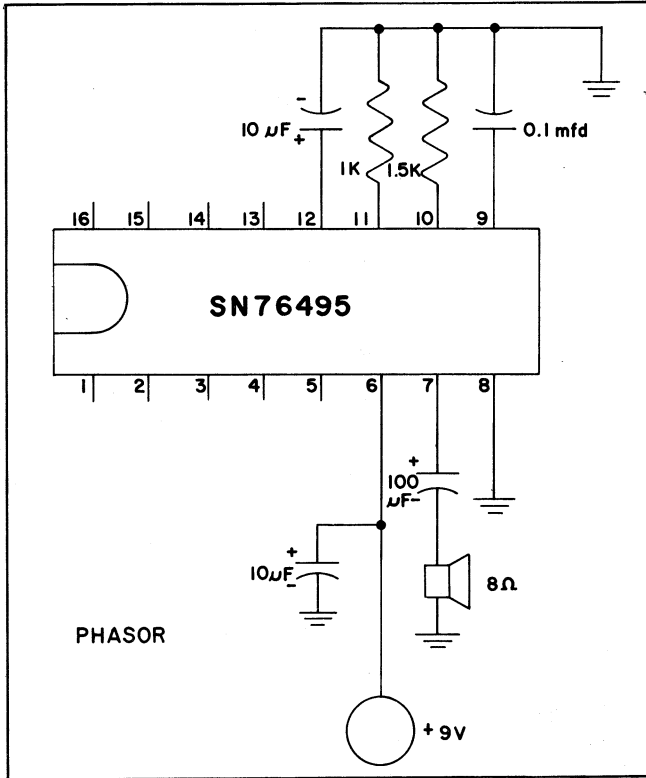

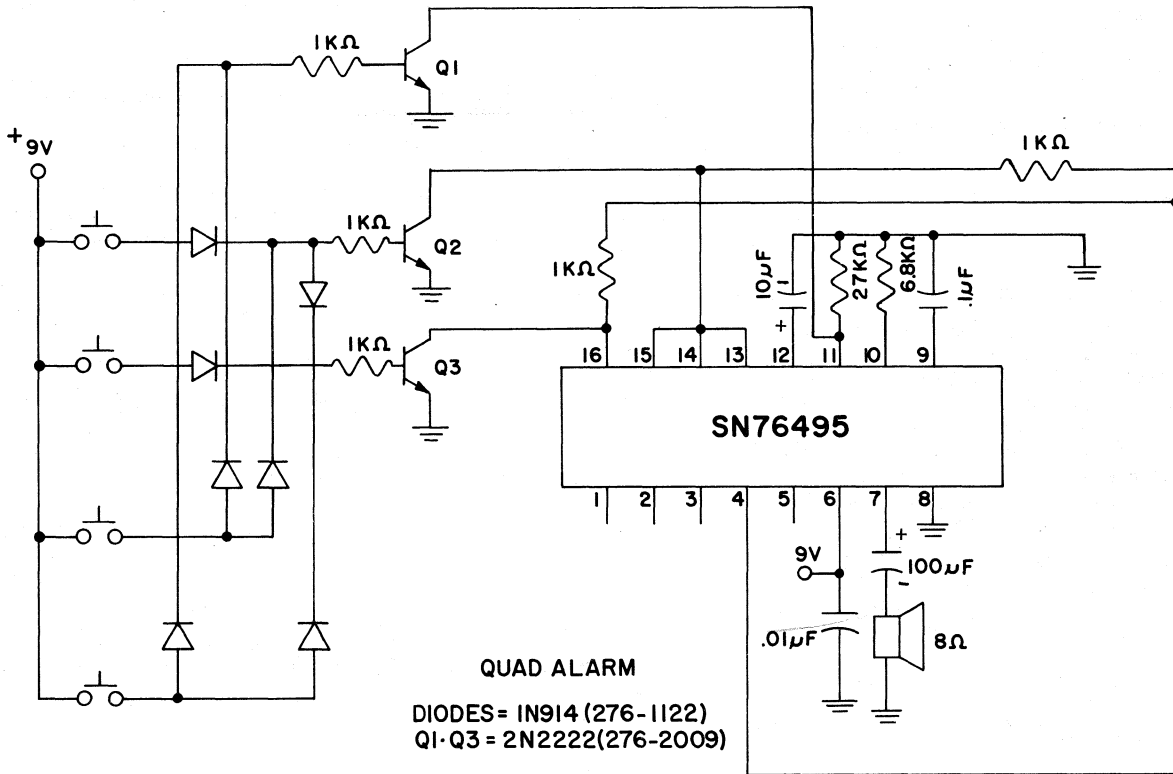

RADIO SHACK, A DIVISION OF TANDY CORPORATION

**U.S.A.: FORT WORTH, TEXAS 76102
CANADA: BARRIE, ONTARIO L4M 4W5**

TANDY CORPORATION

AUSTRALIA

280-316 VICTORIA ROAD
RYDALMERE, N.S.W. 2116

BELGIUM

PARC INDUSTRIEL DE NANINNE
5140 NANINNE

U. K.

BILSTON ROAD WEDNESBURY
WEST MIDLANDS WS10 7JN

Electrical Characteristics at Vcc = 9 Volts, Ta = 25 Degrees C*

* Unless otherwise noted

PARAMETER	PIN NOS.	TEST CONDITIONS	MIN	TYP	MAX	UNITS
Vih High-level input voltage	14,15,16		2.0		9.0	V
Vil Low-level input voltage (Note 2)	14,15,16				0.8	V
Vopp Peak to Peak Output Voltage Swing	7	Rload=8 ohms AC Coupled	1.6	2.0		V
Vreg Regulation Output Voltage	4	Vcc=9.0V, External Load on P4 = 5mA	4.5		5.5	V
Vreg Regulation	4	Vcc=7.5V to 10V, External Load = 5mA		150		MV
Trip Points: Noise Filter Capacitor SLF Capacitor	1			3.2		V
	12			2.3		V
External Vco Cutoff Voltage	12			2.30		V
Iih High Level Input Current	14,15,16	Vih=2.0V		35	50	μA
Control Input Current (Note 3)	2,10,11		-1		-250	μA
Icc	6	Vcc=9V Pins 2,8,10,11 at GND. All other pins open.		19	26	mA

Note 2: Logic pins left open are normally low.

Note 3: All control pins have an internally connected series 7Kohm (typical value) current protection resistor.