

Vintage Radio

by PETER LANKSHEAR

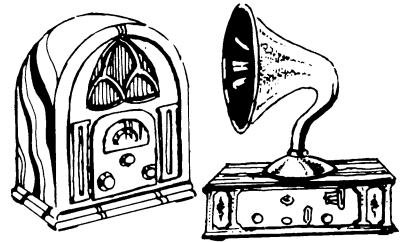

MATE – A handy accessory

Recent comments from vintage radio collectors indicate that there is a need for an alternative programme source, for times when there is an absence of suitable transmissions. If you enjoy demonstrating or listening to your vintage radios, you will find this 'Mate' useful – as well as deriving satisfaction from building some working equipment.

Tapes of the old classic radio shows are becoming very popular, and reproducing them through a radio of the era enhances their entertainment value. Furthermore, increasing numbers of existing AM medium frequency stations are being lost to vintage radio, as they transfer to the FM VHF bands.

A specification was drawn up and some experimental work was done, to see if it would be practical to produce what is in effect a miniature AM broadcast transmitter. The criteria it had to meet were these:

1. Construction should be simple and use components that are readily available and inexpensive.
2. Power and range should be strictly limited.
3. A multimeter should be the only test equipment necessary for setting up.
4. It should accept either monaural or stereo programme input from the headphone or extension speaker sockets of receivers, cassette, CD or record players.
5. Have 90% modulation capability, with no audible degradation of the programme material.
6. Use a minimum of current so that it could be powered from a receiver.

The result was the MATE (Micro Amplitude – modulation Transmitting Equipment). Like radio controlled toys and wireless microphones, it is a limited radiation device transmitting a very low powered signal, sufficient to cover a room or display area. Appropriately, it uses techniques frequently found in early broadcasting transmitters.

At this stage, I would suggest that readers not familiar with the workings

of broadcast transmitters should study the article in the October 1988 issue of *EA*, Part 4 of the 'Basics of Radio Transmission'.

Early AM transmitters

Fortunately for early broadcasters, and this project, a class-C valve oscillator is easy to amplitude modulate, as the relationship between its HT voltage and power output is very linear.

Modulated oscillators can be simple and effective transmitters, and were used by some 'B class' AM broadcasting stations well into the 1930's. They have

limitations, which are somewhat academic in the case of the MATE. These are lack of crystal frequency control and frequency shift with modulation, both of which can create problems for adjacent transmissions.

Heising or choke modulation was general, but during the 1930's, series modulation which needed no expensive choke or transformer was popular – and this seemed to be an attractive proposition for the MATE.

Experiments were promising, and resulted in a single valve oscillator and modulator capable of using common types of double triode. A triode amplifier was added to increase audio gain, and the overall result is a very simple but effective little transmitter.

Why use valves?

No excuses are offered for using valves. Apart from being appropriate for a vintage radio project, valve equip-



The author's prototype for the 'MATE' mini-transmitter, built on a disused power supply chassis.

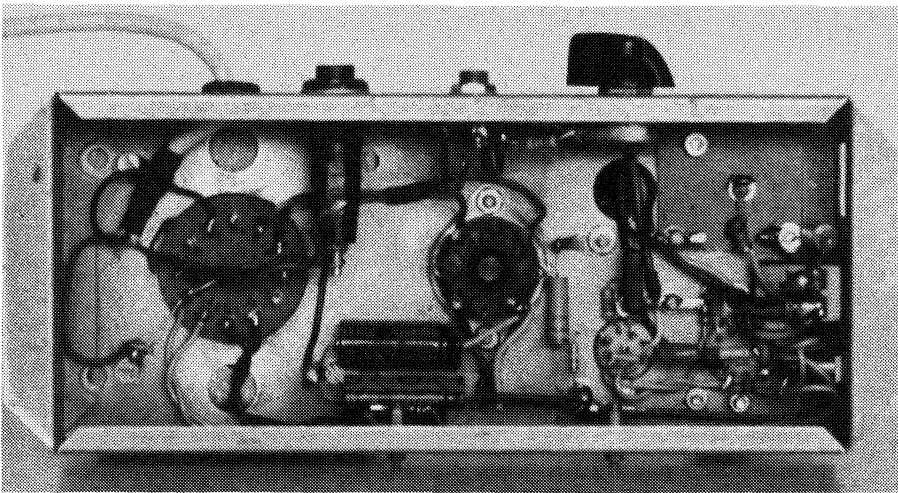

Underneath the chassis of the prototype, which also includes the power supply circuitry.

ment in this case is far less complex and is easier to adjust than a semiconductor unit. The MATE uses only two valves, and a handful of components.

Operation is very simple, and construction and layout are not at all critical. One half of the double triode (V2a) is a classic tuned anode oscillator, with tickler feedback to the grid. The other section (V2b) is the series modulator, which is driven in turn by a resistance-capacitance coupled triode voltage amplifier (V1). The HT current of about 4 milliamps and filament requirement of 6.3V (AC) at 0.6A can easily be supplied by any medium-sized valve radio – or alternatively, a self contained power supply can be used.

Housing for the MATE can be as simple or as elaborate as the builder wishes. The prototype was built on a disused power supply chassis, but a utility box would make a more attractive unit. However, if appearance is not important, there is no reason why it should not be built on an old receiver chassis.

The audio input socket is connected to the modulation level control by a pair of 10k resistors, used to combine stereo signals, with one input being ignored for monaural sources. If the lead from the control to the voltage amplifier grid is longer than a few centimetres, it should be shielded by using a piece of thin coax or screened cable.

The voltage amplifier can be just about any small triode or triode-connected sharp cutoff pentode. Some suitable types are listed in the table. The oscillator/modulator can be a 12AU7/ECC82, 12BH7 or 6CG7. These valves were popular in black and white TV receivers, and if necessary can still be purchased at reasonable prices.

The oscillator is quite similar to a

standard anode-tuned superhet oscillator, except that it is series rather than shunt fed. A receiver oscillator coil is suitable, or one can be readily wound on a piece of broom handle using enamelled winding wire of about 36 SWG or 0.2mm diameter. The tuned anode (plate) winding has 100 turns, while the tickler/grid winding has 25 turns. Small plated nails can be used to provide terminations for the windings.

As the coil is connected to HT voltage it should be kept away from fingers, and if used, a shielding can should have a minimum of twice the coil diameter.

Tuning is controlled by variable capacitor VC1. This can be an old oscillator padder, from a valve set, or even a transistor receiver tuning capacitor. As

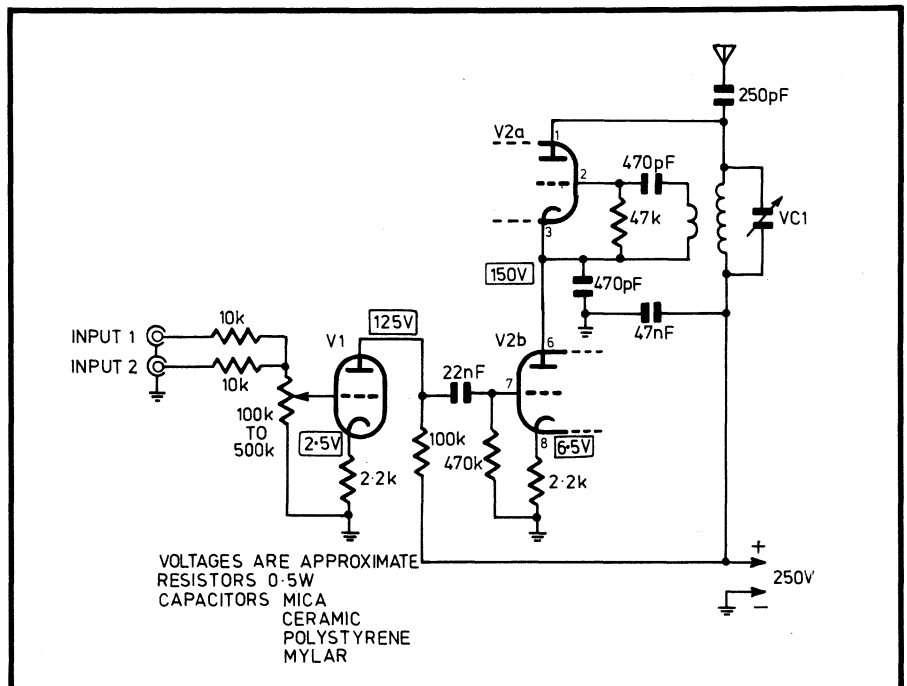

The circuit for the 'MATE' – effectively a very low powered AM transmitter, using a triode RF oscillator V2a series modulated by V2b. Incoming audio is amplified by V1.

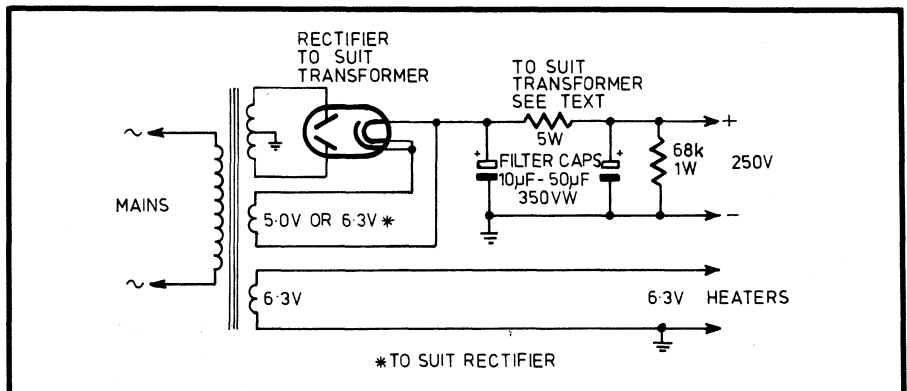

The matching power supply circuit. The value of the series HT resistor needs to be selected to suit the transformer secondary voltage – see text.

Vintage Radio

SUITABLE VALVE TYPES

V1 AUDIO AMPLIFIER Ignore unused sections of multiple valves	V2 OSCILLATOR/ MODULATOR
DIODE TRIODES: 6AV6 6AT6 EBC81 EBC91 PENTODE (Triode Connected): 6AU 6 EF94 DOUBLE TRIODES (One Section): 12AX7 12AT7 ECC83 ECC81 OCTAL (Metal, G or GT): 6B6 6Q7 6SQ7 EBC33	NOVAL: 12AU7 12BH7 6CG7 ECC82 OCTAL: 6SN7

both sets of plates are 'hot', care should be taken to ensure that there is no electrical contact with the chassis.

Although a short length of wire will do for an antenna, a nice touch is a telescopic aerial rod salvaged from a transistor radio or a TV 'rabbit's ear' antenna.

An integral power supply is convenient, but optional. The current drain is so small that just about any transformer with a 6.3 volt heater winding and a 200-volt or greater HT winding will do, along with its associated rectifier. The value of the series resistor is dependent on the transformer voltage, and is best found by experiment. As a guide, a 285 volt transformer needs 15k, whilst for a 385 volt transformer, 33k is about right. The power rating should be at least 5W.

The alternative approach of borrowing power from an existing valve receiver is simple. HT can be picked up from the screen grid pin of the output valve, with the negative lead being connected to the receiver chassis. The heater leads can be conveniently fed from the appropriate pins of the same socket.

Setting up is simple. After checking the wiring, switch on the power and ascertain with a receiver that the MATE is producing a carrier. If it is not, the connections to one of the coil windings may have to be reversed.

To make sure that you are not receiving a harmonic, tune the receiver upwards from the low frequency end of the dial. The first MATE signal encountered will be the fundamental. Now use the tuning capacitor to set the transmission frequency to a section of the

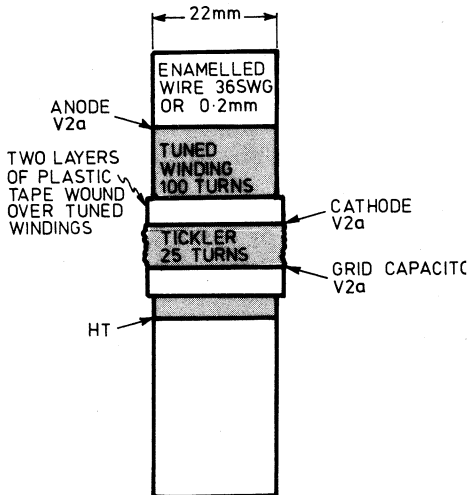

If you want to wind your own oscillator coil, here are the details. The wire should be enamelled copper, or 36 SWG or 0.2mm diameter.

broadcast band that is vacant in your area. Connect your programme source, and adjust the gain control to produce a modulation level that does not cause audible distortion on programme peaks. If you can check with an oscilloscope, limit modulation to 90%.

An unexpected and successful use has been found for my own prototype MATE, shown in the photographs. On a couple of occasions, I have provided background music for functions held in a medium-sized hall. Receivers tuned to the MATE were placed at strategic places around the hall, and volume levels set individually. Much favourable comment resulted from people intrigued by old 'cathedral' radios supplying their entertainment!