

# Vintage Radio

by PETER LANKSHEAR

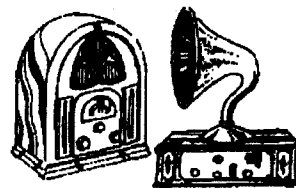

## The Philips 2510 receiver

Philips' first export model receiver, the 2510, was first produced in late 1929 and was one of the first Philips receivers sold in Australasia. Furthermore, it was one of only two Philips models to be sold in both Australia and New Zealand.

Its quality and unusual appearance make the Philips 2510 a justifiably popular receiver, and it has survived in surprisingly large numbers — many New Zealand collectors having more than one. As proof of Philips durability, some are still in working order despite being completely original.

The equivalent larger cased European model called the 2511 had some common features, but clearly the 2510 was a special design. Unlike practically all European receivers, it did not include a longwave band. It is remarkable that Philips bothered to develop a special export model, for what by European standards must have been a very small market.

Already many countries had import restrictions and tariffs to protect their homegrown receivers. It had become

necessary for Philips to look to remote countries like Australia and New Zealand, where broadcasting was established and most radios were still imported.

Philips were by 1929 already well known here for their valves and battery eliminators, and could assume that their receivers would sell easily. It has recently come to light that the 2510 was sold in Brazil, while Argentina and South Africa also had Philips branches and are likely to have sold the 2510 as well.

Philips must have considered these combined markets as having sufficient potential to make the development of a special model a viable proposition. Much of the development work and many of the components for the 2511 were used, however.

Whatever the rationale, the 2510 was

launched. Unfortunately, before production of the 2510 had run its course, Australia too joined the ranks of the protectionists.

This must have been quite a setback. One outcome was that Philips did not develop any more single band receivers — any exports to New Zealand being the standard models, by now being produced in an English Philips factory.

### Two versions

Despite the 2510 being in production for only a couple of years, there were two versions and several small variations as production progressed.

Although a database listing 40 receivers has been analysed, there is no firm relationship between dating and the sequence of serial numbers. Many receivers have, however, a date printed on one

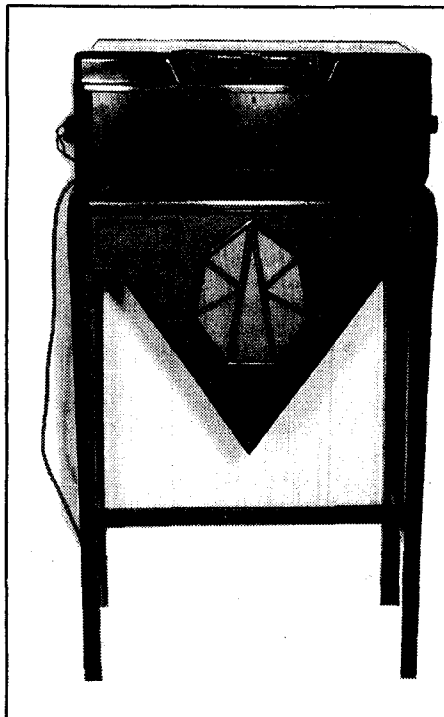

*Fig.1 (right): The 2510 was very popular when combined as shown here with the 'Sevenette' magnetic (moving iron) speaker.*

*Fig.2 (left): Another popular combination was the 2510 with the 'Consolette', a table of unusual design and incorporating an early 'permagnetic' moving coil loudspeaker.*

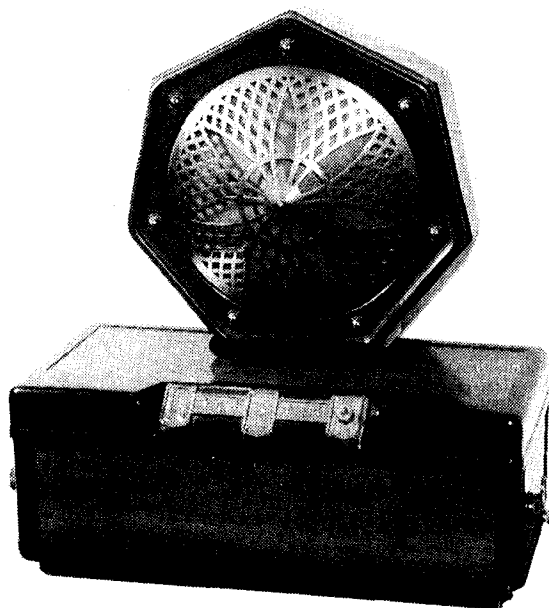

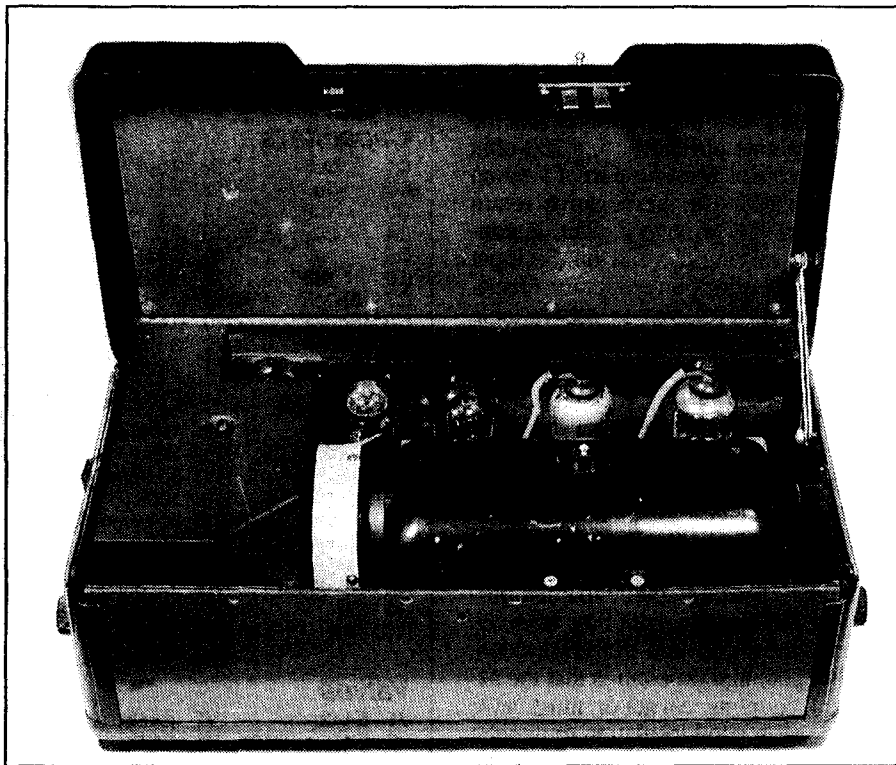

**Fig.3:** *There's not a lot visible under the lid of the 2510. Here the valve shielding box has been removed, but the tuning capacitor is still hidden by its curved shield and the power supply by the protective box visible at the left.*

of the bypass capacitors. One difference readily distinguishes the early version from later models: the main escutcheon plate in the early models has six stars, whereas later there was only a single star. Later still, the keyhole was given a metal surround.

A real mystery surrounds a few New

Zealand models with low serial numbers. Instead of the maker's plate being marked 'Made in Holland', the caption reads 'Assembled in N.Z.'. Leading one to speculate what for, and by whom?

Given the type of construction, and facilities available at the time, only very nominal assembly could have been un-

dertaken. There are no differences to distinguish the N.Z. version. Were there any Australian assembled models? If any reader knows of one, please let me know.

## US equivalents

As a mains powered TRF in a 'chest' type cabinet with separate loudspeaker, and with two screen-grid RF amplifier stages, the 2510 was a European equivalent of familiar 1929/30 American receivers such as the Atwater Kents, Crosleys and Philcos. There are interesting design details, which illustrate some of the differences between contemporary American and European technology and construction.

Many 2510's were supplied with a 'Sevenette' free standing moving iron speaker, but an alternative was Philips' first permanent magnet moving coil speaker, the 'Permagnetic', available in some rather stylish cabinets designed by a Sydney architect. There was also the unusual 'Consolette', which consisted of a table to support the receiver and with the speaker mounted underneath.

## Side controls

Except for the on/off switch, there are no controls at the front of the receiver. Instead, tuning and volume controls are at the ends of the cabinet.

One odd feature has created a lot of speculation. There is a lock for the lid which, despite what is claimed in the instruction book, does not prevent unauthorised use of the receiver. All it does is to prevent access to the interior. It is

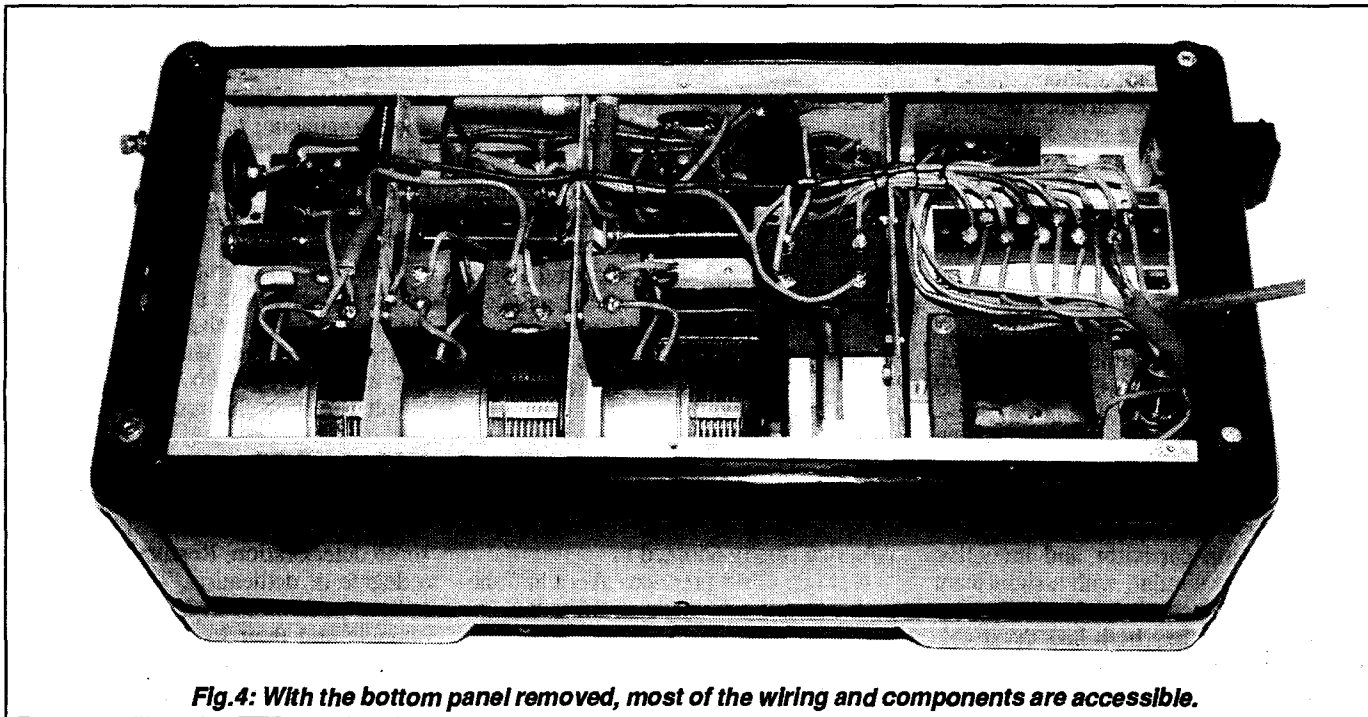

**Fig.4:** *With the bottom panel removed, most of the wiring and components are accessible.*

## VINTAGE RADIO

not necessary for safety — there is an automatic cut-out switch connected to the lid. One possibility is that this is a hangover from the model 2511's lock, which had a second position locking the wavechange and mains switches.

### Novel cabinet

The colloquial term 'tin trunk' for the 2510 is not really very appropriate. In fact, the case consists of a metal frame and panels of 'Vanherite', made from sheets of paper impregnated with thermosetting resin and cured under high compression. A printed wood grained pattern on the outer paper sheet provides a high gloss decorative finish. The removable panel on the underside of the cabinet, providing access to the wiring, is a feature which was to become common Philips practice.

Internal construction of the 2510 is quite different from the conventional chassis. Instead, the Philips format is more three dimensional, the entire assembly being carried in a very solid metal frame. At the rear is a row of valve sockets and many of the larger resistors, wound on glass tubing. To the front of the valve sockets is a beautifully made brass vaned three-gang tuning capacitor with an integral drum dial drive, and under this are three cylindrical cans — almost certainly containing toroidal tuning coils.

Shielding partitions across the frame provide mounting surfaces for smaller components. Separate covers are used for the tuning capacitor and power supply, and there is a compartmented shield box for the first three valves. The compact power supply is a separate module at the left hand end of the cabinet.

### Salient differences

One electrical difference from contemporary US designs is right at the aerial terminal. American broadcast receiver practice was to couple the aerial inductively with a small primary winding on the tuning coil, whereas Philips favoured coupling via a small series capacitor, with a value of 13pF in the case of the 2510. In later models, a second capacitor of only 4pF was provided for use with large aerials.

Results with capacitor and inductive coupling were similar, with a significant increase in sensitivity with increasing frequency, and they both had the disadvantage of detuning the input stage with changes of aerial. Later these methods were superseded by high impedance pri-

mary windings, which provided a more even response and minimal detuning.

Using a type E442 screen-grid valve, the first amplifier stage incorporates the gain or volume control R15, a 200-ohm variable resistor forming part of a string of bias resistors in the negative return lead of the power supply. Gain is controlled by varying the bias on the input stage control grid. Contemporary American designers preferred to use variable cathode bias or screen voltage, often linked to another variable resistor connected to the aerial.

In another divergence from the common American practice of using primary windings for RF coils, Philips connected the anode of the first RF stage directly to the second tuned circuit. This has the disadvantage of placing HT voltage on the tuning capacitor stator, and can provide an undesirable coupling between the following grid and the HT system. Another potential problem is that the associated coupling capacitor must have exceptionally good insulation to prevent the grid bias of the following valve being upset by the leakage of HT voltage.

In a similar manner, the anode of the second RF stage, another E442, is directly connected to the detector tuning coil.

### Traditional detector

The detector is a traditional grid-leak type — sensitive, but in 1929, already obsolescent in high quality broadcast receivers. Its chief disadvantage in this application is serious distortion at high modulation levels, a greater problem today with transmissions relying on heavy audio processing to compete in the ratings game.

Connection of a gramophone pickup is ingenious. Plugging the pickup, which would have had its own volume control, into the socket at the rear of the cabinet automatically connects the valve grid to a bias line, converting the detector into an amplifier stage. Early sets used a type E415 triode but for later models a higher amplification factor E424 was specified.

The pentode output valve is the major feature distinguishing Philips technology in the 2510. The Americans were still using triodes, usually a pair of low- $\mu$  type 45 valves. Philips engineers had invented the pentode a couple of years previously, but it was not until 1931 that America finally adopted it.

A single C443 produces about half the audio power of a pair of 45's, but requires only one third the anode current. By using the more sensitive and efficient pentode, Philips receivers saved one stage of amplification.

## PHILIPS 2510: Component values

### Capacitors

C1	5uF	C12	0.5uF
C2	4uF	C13	0.5uF
C3	1uF	C14	0.5uF
C4	2uF	C15	0.5uF
C5	1uF	C16	13pF
C6	1uF	C17	13pF
C7	550pF	C18	0.5uF
C8	1650pF	C19	0.5uF
C9	40pF	C20	0.5uF
C11	0.5uF	C27	(4pF)

### Resistors

R1	50k	R11	100k
R2	200k (100k)	R12	20k
R3	40k	R13	35 ohms
R4	38k (30k)	R14	100k
R5	50k	R15	200 ohms
R6	40k	R16	100 ohms
R7	2M	R17	50 ohms
R8	38k (30k)	R18	50 ohms
R9	2M	R19	225 ohms
R10	30k	R20	40k
		R21	50k (100k)

### Valves

V1	E442	V2	E442
V3	E415 or E424	V4	C443
		V5	506

Values in brackets are for 1931 models. Some sets do not have C14 or C20.

The output transformer has a tapped secondary winding connected to two sockets, L1 for high impedance moving iron speakers and L2 for connecting directly to voice coils.

Here is another puzzle. In a 1931 data sheet, the output transformer has a turns ratio calculated to make the L2 impedance a remarkably high 64 ohms. However, direct measurements on both the 2510 and permagnetic speaker in the photograph result in a figure of 28 ohms.

Rather than being switched, the tone control capacitor is mounted in a 'tapon' type of plug called a 'tone filter'. This is plugged into L1, and high impedance speakers are connected to the back of the filter.

With paper filter capacitors and a filter choke in series with the bias resistors in the negative lead, the power supply is quite conventional. The full wave rectifier valve is a Philips type 506 with a 4-volt 1-ampere filament.

### Restoration

Although as a class the 2510 has survived well, many will have suffered from some deterioration. Restoration calls for a degree of dedication. Take some time to become familiar with the various components and their locations. When you do start work, remember that the valve top caps are the anodes, and have a high voltage on them!

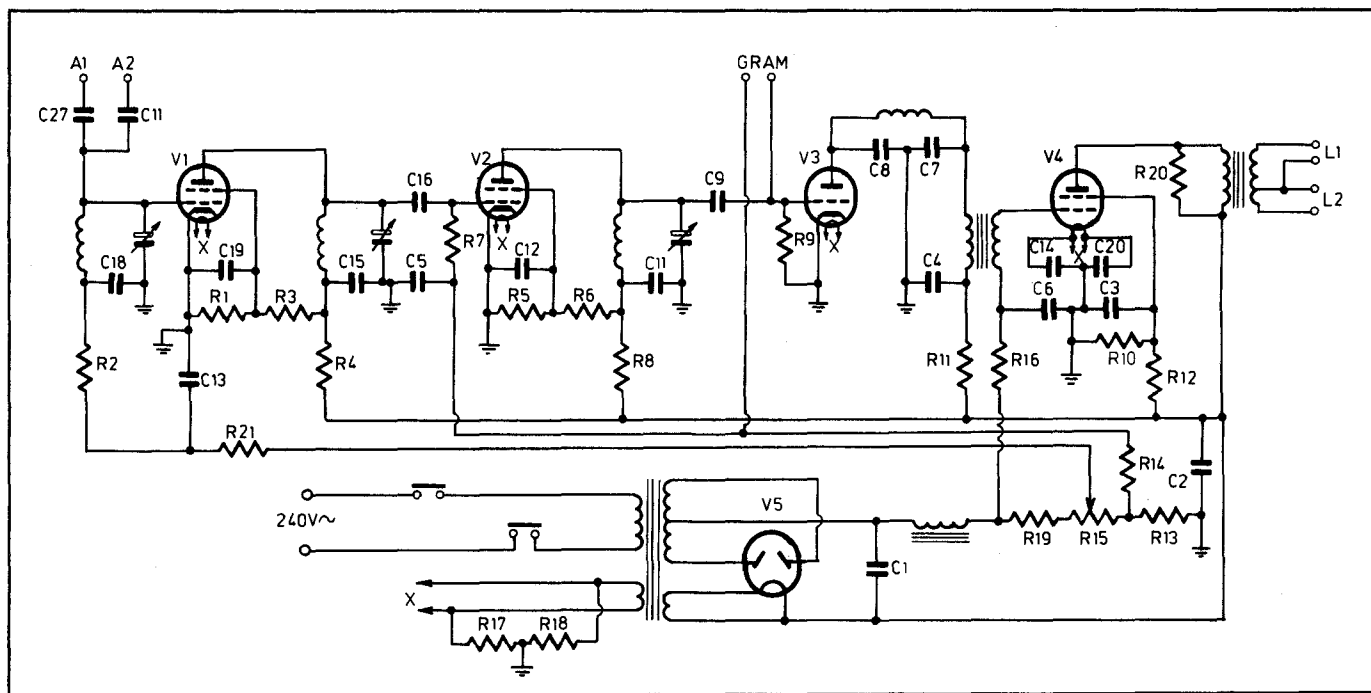

**A redrawn circuit schematic for the 2510. The original drawings that are available are somewhat illegible.**

A major problem is finding replacement valves. The sharp-cutoff E442 and the equivalent S4V Mullard screen-grid RF amplifiers were obsolete within a couple of years. Their successors, the Philips E452 and Mullard SP4, are far too tall.

If your main concern is to get a 2510 operating, some of the smaller English 5-pin RF valves will do. Two types that will fit are the Mazda AC/SG and the Osram Catkin VMS4. However, if variable- $\mu$  types are used in the V1 socket, the range of volume control will be inadequate.

### Possible problem

The restricted height has created another restoration problem. To fit oversized replacement valves, which by now were spray shielded anyway, many servicemen discarded the valve shield box or cut holes in its top. Fortunately, it is possible for a competent sheetmetal worker to make a copy.

Not so easy to remedy was one effort where, to accommodate a SP4, some vandal had cut a hole in the cabinet lid!

The situation with the C443 is a little better, with the CV1167 and Mullard PM24A able to be used as direct equivalents. Often though, a type E443 or similar 5-pin power pentode will be found in a 2510. These alternatives should be used with caution, as their greater anode and filament currents could overload the power supply.

Type E415 or E424 detector triodes are easier to find, and equivalent 4.0-volt 1-

ampere heater general purpose triodes were made by all European manufacturers. Many rectifiers with 4 volt 1-ampere filaments can substitute for the 506. Some suitable types are Philips 1805, 1821 or 1823, Brimar R1, Marconi/Osram U10, and Mullard DW2.

Typically of Philips safety philosophy, the cabinet lid is fitted with a mains cut-out switch. This is not much of a problem, as best servicing access is from underneath. Removal of the bottom panel reveals most of the wiring, consisting of varnished cambric sleeving over tinned copper wire.

In some instances, the original sleeving will have perished into a sticky mess. The best remedy is to unsolder each lead one at a time, and renew the sleeving. Mineral turpentine is useful for removing residues. (Remember that earlier I used the term dedication.) One benefit of this work is that you become familiar with the circuit!

### Rebuilding capacitors

Next test the capacitors for leakage. These are sealed in tinfoil boxes mounted on the partitions. The method of grid biasing is intolerant of leakage in bypass capacitors. If C5, C6, C13, and C18 measure less than about 10 megohms, renew the contents.

Repairing the capacitors is simple enough. Uncrimp the edges of the box to release the fibre top, and dig or melt out the pitch. Replacement mylar or polyester dielectric capacitors will generally fit inside easily.

Refilling with melted pitch is desirable, but optional — and do not have it too hot, or the capacitors may well be damaged.

Be especially wary of the grid coupling capacitors C9 and C16. The slightest leakage here can be disastrous. They are inside small cylindrical fibre sleeves which should be retained, and are best replaced by tubular ceramic types.

The resistors are of novel construction, being wound or deposited on glass tubes. Contact is made by soldering to metal rings at the ends of the elements, and R3 and R6 have extra rings to serve as tie points.

The large wirewound resistors do not give much trouble, but the high value types R5, R7, R9, R14 and R16 are likely to have considerably altered in value. Some of these will be found inside sleeving and should be extracted carefully. To repair them, clean off the remaining resistive coating and insert new 1/4-watt replacement resistors inside the tubes.

Finally, the trimmer capacitors are inaccessible unless the whole assembly is removed from the cabinet. This does mean that knobs and fittings have to be removed before attempting realignment, but on the other hand, generally there will have been less 'tweaking' in the past.

### Acknowledgement

I am indebted to John Stokes for making available research and valuable historic information, for this look at the Philips 2510. ■