

1926 IC radio sold 1,000,000 models!

# The world's first integrated circuit

Did you know that the world's first integrated circuit was produced in 1926? Not that it was anything like the familiar solid state devices of today but was, instead, the unwieldy product of vacuum tube technology. However, this did not deter it from going into mass production for incorporation into a highly successful radio receiver which sold more than one million models.

by WILLIAM A. GOLD, B.Sc (Eng.)

To most of us, integrated circuits are a fairly modern development. They are the familiar looking "beetles" or "tin hats" which have revolutionised the electronics industry in recent years, and will have an even greater impact in the future.

The modern era of integrated circuits began in 1958 when prototype microcircuits were developed by both Texas Instruments Inc., Dallas, Texas, and Westinghouse Electric, Youngwood, Pennsylvania. These prototype ICs were rather crude devices, consisting of separate semiconductor chips carrying transistors, diodes and resistors, all mounted on a common header. Since then manufacturing techniques have improved enormously.

Over the last two years or so, the trend to what is termed large scale integration, or LSI has gathered momentum. More and more complex circuits and subsystems are being crammed into integrated

circuit packages, making possible a range of high technology products for everyday use. Witness for example the explosive growth of the calculator industry during the past eighteen months; or the increasing application of minicomputer systems and microprocessor equipment.

Because of this, we associate integrated circuits exclusively with the electronics of today. They range in application through all branches of electronics—radio and TV receivers, hifi equipment, process control systems, digital clocks and watches, computers, communications and broadcasting equipment, and instrumentation, to name just a few.

It may come as something of a shock, then, to learn that the world's first integrated circuit was developed just over fifty years ago. What's more, the IC was mass produced and incorporated into a radio receiver.

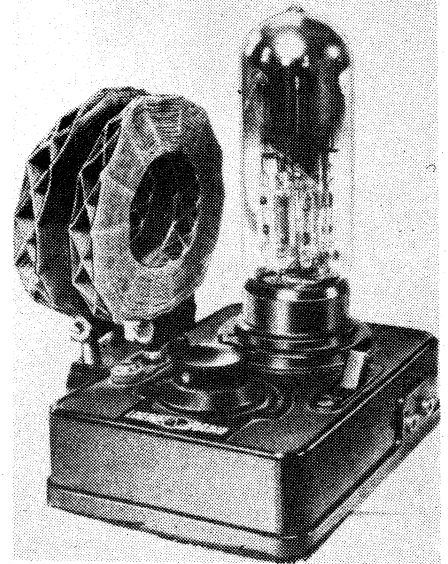

Fig. 1: the Loewe OE333—the world's first million selling radio receiver.

Of course, the world's first integrated circuit looked nothing like the IC's of today, although the basic concept was the same. As would be expected, it employed vacuum tube technology, the device essentially consisting of three triode valves and a number of resistors and capacitors encapsulated in a common glass envelope. By today's standards, the device was quite bulky and somewhat fragile.

The man credited with developing the world's first integrated circuit is Dr. Siegmund Loewe, founder of the Loewe-Opta electronics company of Berlin, Germany, who was granted a patent for his idea in 1924. The patent application described a vacuum tube device containing two valves, two coupling capacitors and two resistors within a common glass envelope. External connections were brought out to a polarised pattern of access pins, which could be plugged into, or withdrawn from, a corresponding socket.

By 1926, a device slightly more complex than that described in the patent application had been designed and put into production. This was the

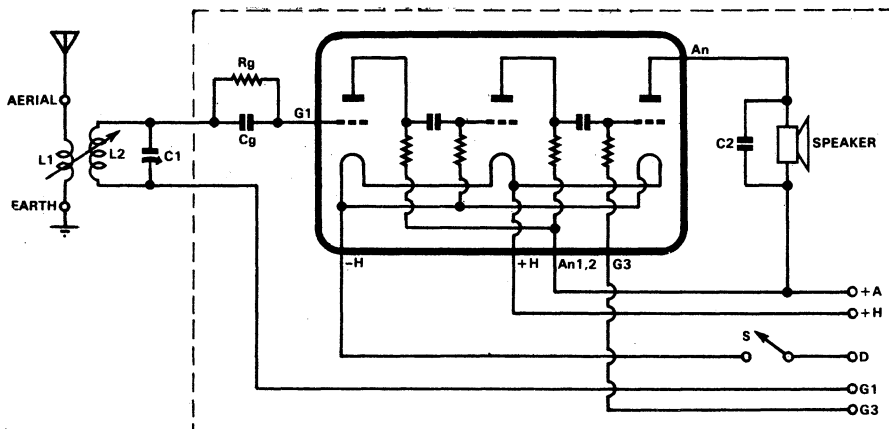

Fig. 2: the circuit diagram of the Loewe OE333 radio receiver. The triple triode IC comprised all those components within the solid dark line.

triple triode integrated circuit referred to above. It was incorporated into the Loewe OE333 radio receiver, more than one million of which were sold within twelve months of its 1926 launching.

Basically, the triple triode IC used in the OE333 contained virtually a complete radio receiver within a single glass envelope. The only other components required were a tuning coil, a "swinging" aerial coupling coil, a tuning capacitor, a loudspeaker, and the high tension and low tension batteries which supplied anode and filament power respectively.

The complete circuit diagram of the Loewe OE333 radio receiver is shown in Fig. 2. Battery operated, the receiver simply consisted of a triode anode-bend

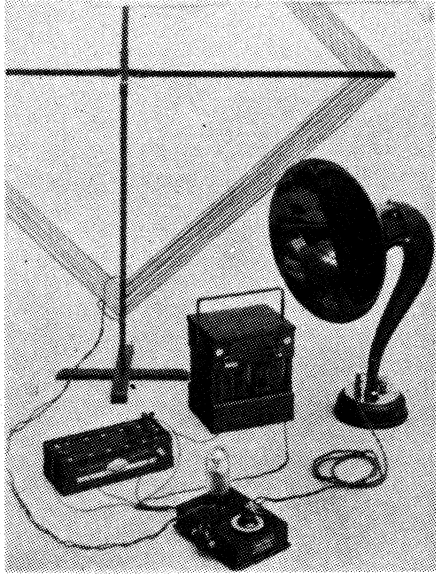

Fig. 3: the Loewe OE333 IC radio with batteries, frame aerial and speaker.

detector stage, followed by two stages of triode valve amplification.

The anode-bend detector was RC coupled to the first amplifying stage which, in turn, was RC coupled to the second. Output from the second stage was then direct coupled to a loudspeaker, almost certainly of the high impedance moving reed type, although moving coil loudspeakers were in use in high grade equipment at that time.

The receiver was said to provide good loudspeaker performance using an indoor aerial in areas served by effective local and regional broadcast transmitters. An outside aerial was required for more distant station reception.

Fig. 3 may evoke nostalgic memories for some of our older readers. It shows the OE333 receiver surrounded by the now antiquated high-tension battery, a low-tension acid-filled accumulator used for heating the valve filaments, an exponential horn loudspeaker, and the once quite common diagonal frame directional aerial. The latter could be used to replace the more compact pancake-wound aerial and tuning coils, and was of such inductance as to correctly

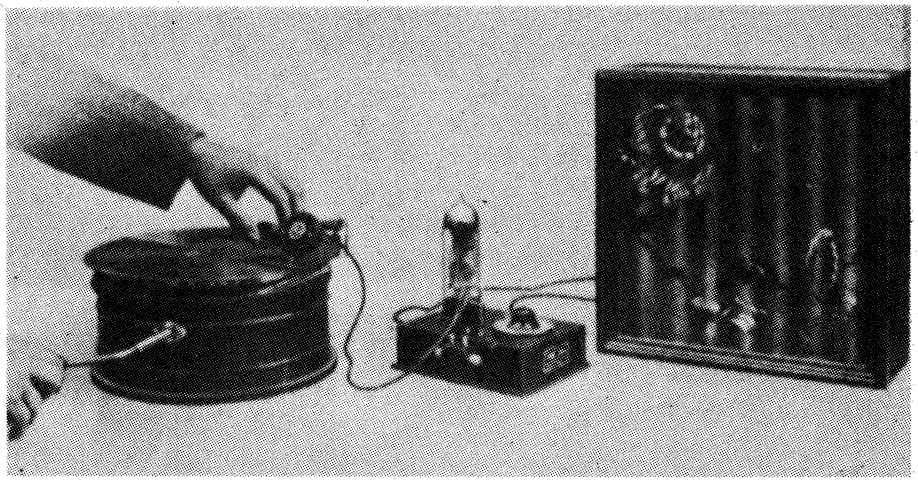

Fig. 4: a 1928 version of the OE333 in use as an amplifier for record playing equipment. Note the hand-cranked turntable.

tune across the broadcast band with the aid of a tuning capacitor.

Fig. 4 shows the OE333 of 1928 in record player guise. Here the triple stage vacuum tube integrated circuit is being used to amplify the signal from a primitive electromagnetic pick-up head grazing an old 78 rpm gramophone record. A hand-cranked clockwork motor supplied rotational power to the turntable.

Cost of the OE333 receiver without batteries and loudspeaker was 39.50 Reichmarks, equivalent today to about \$A10. The currency translation is, however, only approximate due to inflation,

the lapse of time, and the momentous political events between 1926 and 1976. Certainly for its time the OE333 must have been very competitively priced, it being the first radio receiver in the world to sell in excess of one million units.

It would be a cynical electronics engineer of today who did not concede that Dr. Siegmund Loewe—engineer, inventor and founder of the Loewe Opta Company of Berlin—was the man who gave the world its first cost effective integrated circuit, and successfully mass produced more than one million such ICs half a century ago.