



Model ACT-2000

OWNER'S MANUAL

23-Channel AM Mobile
Citizensband
Transceiver



GENERAL

Your new Beta ACT-2000 is a professional quality 23 Channel AM Citizens Band transceiver. It has many innovative engineering and user functions. Careful reading of the Instruction Manual before operation is essential for proper operation and prevention of damage.

PACKING

This unit has been especially protected for shipment. Open the carton carefully to avoid damage. Examine the unit for any visible damage. If the transceiver has been damaged in shipment, save the box and packing material and notify the transportation company.

DESCRIPTION

RECEIVER

Super sensitive dual conversion circuit employing a new RF amplifier stage. Sensitivity less than 1/2 microvolt on AM.

A ceramic filter provides a high degree of selectivity and rejection of unwanted adjacent channel signals. Additional receiver features include: RF gain, variable squelch, noise eliminator, delta tuning, push-pull audio and metering.

TRANSMITTER

High efficiency is obtained through use of select components and sophisticated engineering design. An AMC circuit is employed to provide maximum "Talk Power" without distortion.

POWER SUPPLY

Either Positive or Negative ground 12 Volts DC (13.8 VDC EIA) is built in.

OPERATION OF CONTROLS

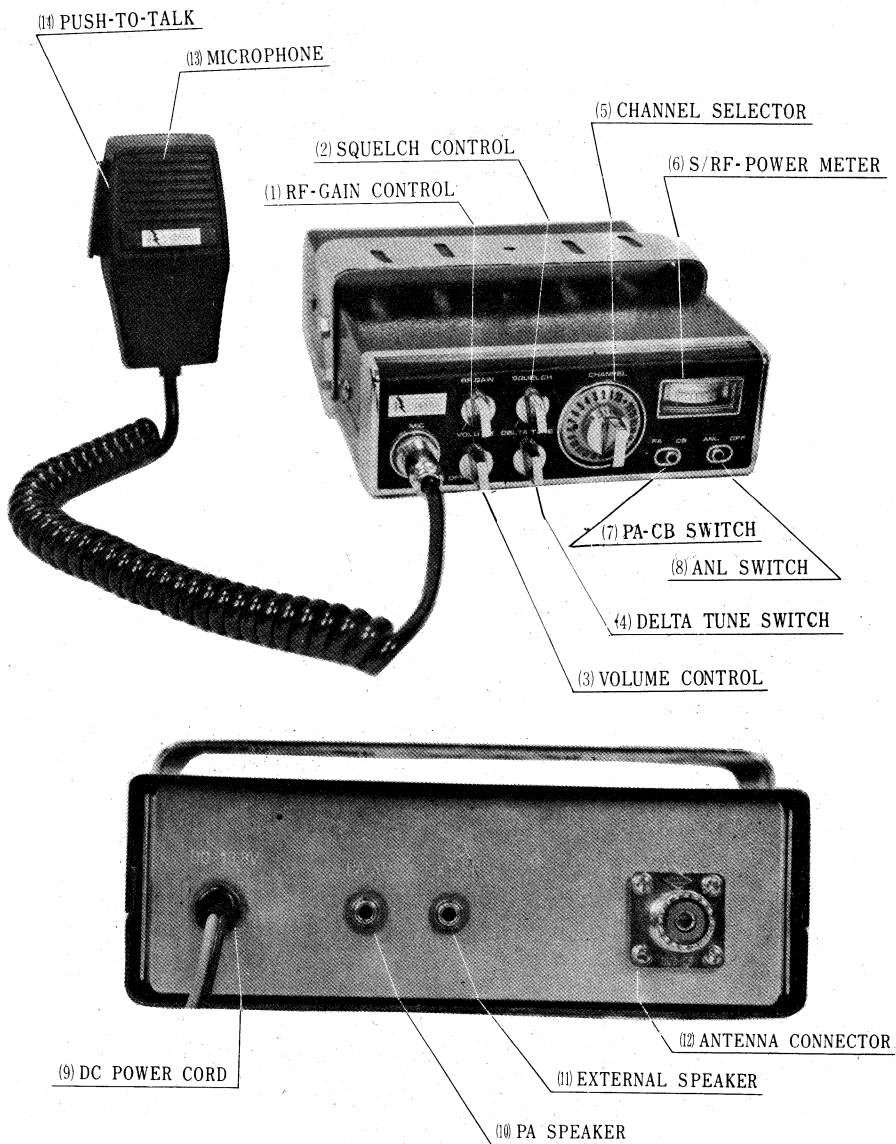

- Front View:
1. RF GAIN CONTROL
 2. SQUELCH CONTROL
 3. VOLUME CONTROL
 4. DELTA TUNE SWITCH
 5. CHANNEL SELECTOR
 6. S/RF-POWER METER
 7. PA-CB SWITCH
 8. ANL SWITCH

- Rear View:
9. DC POWER CORD
 10. PA SPEAKER
 11. EXTERNAL SPEAKER
 12. ANTENNA CONNECTOR
- Microphone:
13. MICROPHONE
 14. PUSH-TO-TALK

1. RF GAIN

NOTE: FOR NORMAL MAXIMUM RECEIVING RANGE THIS CONTROL MUST BE IN ITS MAXIMUM POSITION (FULLY CLOCKWISE)

The “RF Gain” control lets you adjust the sensitivity (receiving range) of your ACT-2000. For maximum range reception, the control should be turned up to maximum (fully clockwise).

In some cases, you may find yourself operating within a very close distance to another station. When extremely strong signals are present, they sometimes have a tendency to “overload” and distort. (Two mobiles within a half mile driving down the same highway or a mobile driving past a base station may generate this condition). While a wide range electronic AGC circuit is incorporated in your ACT-2000, it cannot cope with the wide variances that occur. This is the purpose of the RF Gain control. It lets you manually adjust the receive capability to prevent distortion and overload on strong signals. Should this condition occur, simply turn the RF Gain control in a counter clockwise position until the audio is clear and crisp.

REMEMBER – FOR MAXIMUM RECEPTION, ALWAYS RETURN THE CONTROL TO ITS MAXIMUM GAIN POSITION.

2. SQUELCH CONTROL

The squelch control is used to eliminate background noise when there are no signals present strong enough to overcome the noise. To adjust the squelch control, select a channel where there is no signal. Turn the volume up to normal listening levels. Rotate the squelch control clockwise until the background noise disappears.

3. VOLUME/POWER ON-OFF/PA LEVEL

This combination control supplies power to your ACT-2000 and adjusts the receiver and PA volume. The switch should be turned clockwise from the “Off” position. You will hear an audible “click”. The channel dial and meter will light. To adjust the volume continue advancing the control in a clockwise position.

When you switch the “CB-PA” switch to the PA position, this control allows you to adjust the level of the PA output. To increase PA output rotate in a clockwise position. To decrease simply turn in a counter clockwise position.

For maximum PA output power the control must be in a maximum position (fully clockwise).

4. DELTA TUNE

The Delta Tune is an electronic tuning circuit which allows you to shift the frequency of your receiver plus or minus 1 KHz (2 KHz total).

This allows you to compensate for an incoming signal which may be slightly off the center frequency. Adjust the Delta Tune circuit for maximum "S" meter reading.

5. AUTOMATIC NOISE LIMITER

Your ACT-2000 is equipped with a sophisticated electronic noise eliminator system to greatly reduce extraneous noise coming into the receiver. In effect, noise pulses are clipped from incoming signals before they reach the amplification stage of the receiver. This causes no loss in the signal receive level. The ANL circuit should normally be left on. A switch has been provided to eliminate this circuit if desired.

6. PA-CB

In the "PA" position, your ACT-2000 is converted to a public address amplifier or hailer. The PA function should not be used unless an 8-16 ohm external speaker is connected to the "PA" Jack located on the back of the chassis. Once this optional speaker has been connected, simply put the PA-CB switch to the "PA" position and depress the microphone push-to-talk switch.

NOTE: THE VOLUME CONTROL ADJUSTS PA OUTPUT LEVEL.

7. S/RF METER

The ACT-2000 is equipped with a large, easy-to-read combination meter with a built-in transmit and modulation light.

In the receive position, the meter reads the level of the incoming signals.

In the transmit position, it indicates relative power output. The intensity of the light will vary with your voice to indicate modulation.

8. CHANNEL SELECTOR

The channel selector switch is used to select the fixed center frequency. It automatically adjusts both the receive and transmit frequencies. Set the selector switch to the desired channel.

9. PA SPEAKER JACK

For attaching optional 8-16 ohm PA speaker. Use 3.5 mm jack.

10. EXTERNAL SPEAKER JACK

You may add any 8-16 ohm external speaker. Simply plug your accessory speaker into the jack. Inserting the 3.5 mm plug will automatically disconnect the internal speaker.

11. ANTENNA CONNECTOR

A standard SO-239 type connector is supplied for attaching either mobile or base antennas.

12. DC POWER CORD

To attach to power source.

13. MICROPHONE

The receiver and transmitter are controlled by the press-to-talk switch on the microphone. To transmit, simply press in this switch. Release the switch to receive. When transmitting, hold the microphone 3 to 4 inches from your mouth and speak clearly at normal voice levels.

SPECIFICATIONS

GENERAL

- | | |
|-------------------------|---|
| 1. Semiconductors | : 19 Transistors and 15 Diodes |
| 2. Frequency Range | : 26.965 MHZ – 27.255 MHZ |
| 3. Mode of Operation | : AM |
| 4. Controls | : Volume Control with power on-off switch
: Variable RF Gain Control
: Variable Squelch Control
: Delta Tune Switch
: Channel Selector Switch
: CB-PA Switch
: ANL Switch |
| 5. Connectors and Jacks | : Microphone Connector
: Coaxial type Antenna Connector
: Public Address Speaker Jack 3.5 MM
: External Speaker Jack 3.5 MM |
| 6. Speaker | : 3-1/2 inches, 8 ohms |
| 7. Microphone | : Dynamic Microphone (500 ohms) |
| 8. Power Supply | : 13.8 VDC Positive or Negative Ground |
| 9. Dimensions | : 7''(W) x 2-3/8''(H) x 7-11/16''(D) |
| 10. Weight | : 4 LBS. |

RECEIVER

1. Sensitivity at S/N 10dB : $0.5\mu\text{V}$
2. Selectivity : 5 KHZ
3. AGC Figure of Range : 80 dB
4. Squelch Range : $0.5\mu\text{V} - 500\mu\text{V}$
5. Audio Output Power : 4 Watts
6. Distortion at input $100\mu\text{V}$: 6%
7. Audio Frequency Response : 400 – 2000 HZ
8. Supurious Response : More than 45 dB supurious signal is required to produce the same amount of audio output as the desired receive signal.
9. IF Frequency : 1st ... 10.595 – 10.635 MHZ
2nd ... 455 KHZ
10. Current Drain no audio : 250 mA

TRANSMITTER

1. RF Output Power : 4 Watts
2. Modulation Capability : More than 70%
3. Harmonic Suppression : More than 50 dB
4. Current Drain : 1500 mA

POWER SUPPLY

Your ACT-2000 as supplied operates from a + 13.8V. DC power source (EITHER POSITIVE OR NEGATIVE GROUND)

NEGATIVE GROUND HOOKUP:

Attach the red (fused) wire to the fuse block terminal or any convenient plus (+) lead. Devices operated by the ignition key such as the radio, light etc. are best since when you turn the ignition off, the unit will be turned off. Attach the black lead to the car body via any convenient method.

NOTE: Many newer cars use plastic dash pieces. Make sure the screw or contact you choose is attached to the metal framework of the car.

POSITIVE GROUND HOOKUP:

In the event that you do have a positive ground vehicle, the following hookup must be made. Attach the red (fused) lead to the car body via any convenient screw, bolt etc. Attach the black lead to the terminal block or any convenient wire which goes to the minus (-) pole of the battery.

FAILURE TO MAKE THE PROPER CONNECTION CAN RESULT IN UNIT DAMAGE.

ANTENNA REQUIREMENT

This transceiver will operate with any standard 52 ohm ground-plane, vertical, mobile whip, long wire or other CB antenna. A standard SO 239 type connector is provided on the back panel for use with popular PL 259 antenna plug.

ANTENNA INSTALLATION

BASE STATION:

When the ACT-2000 is used as a base station, any Citizens Band beam, dipole, ground plane or vertical antenna may be used. A ground plane type will provide greater coverage and, since it is essentially non-directional, it is ideal in base station to mobile operation. From base station to base station, or point to point operation, a directional beam will give greater distance even under adverse condition. The range of the transceiver depends basically on the height of the antenna and, whenever possible, select the highest location within F.C.C. limits. (These regulations limit the antenna height to 20 feet above an existing structure). Generally a maximum of 26 feet of lead-in cable should be used due to line losses. However, a desirable antenna location may justify the loss in extra lead-in-length.

MOBILE ANTENNAS:

A vertical whip antenna is best suited for mobile use. A non-directional antenna must be used for best results in any case. The base loaded, whip antenna will normally provide effective communication. For greater range and more reliable operation, a full quarter-wavewhip should be used. Either of these antennas use the metal car body as a ground plane and the shield of the base lead as well as the metal case of the transceiver should be grounded. A standard antenna connector (type SO 239) is provided on the transceiver for easy connection to a standard PL 259 cable termination.

MOBILE INSTALLATIONS

A location in the car or truck should be chosen carefully for convenience of operation and non-interference with normal driving functions. Mounting may be under the dash or instrument panel or any place a secure installation can be made. The carrying handle again serves as the mounting bracket or additional perforated straps or brackets may be used as desired. The 12 volt cable may be connected to any convenient terminal but preferably to the ignition switch to prevent unauthorized persons from operation of your unit. With this method the unit will only operate when your key is turned on. Engine ignition interference should not be a problem and vehicles equipped with standard broadcast radios will have enough suppression to eliminate ignition interference. If interference is present, any skilled auto radio repairman should be able to eliminate it for you.

BASE STATION INSTALLATIONS

When a proper power supply is used, simply connect the red (+) and black (-) terminals on the power supply to the (+) and (-) leads on your ACT-2000. Do not attempt to operate this transceiver by connecting directly to 110 Volts AC.

MOUNTING INSTRUCTIONS

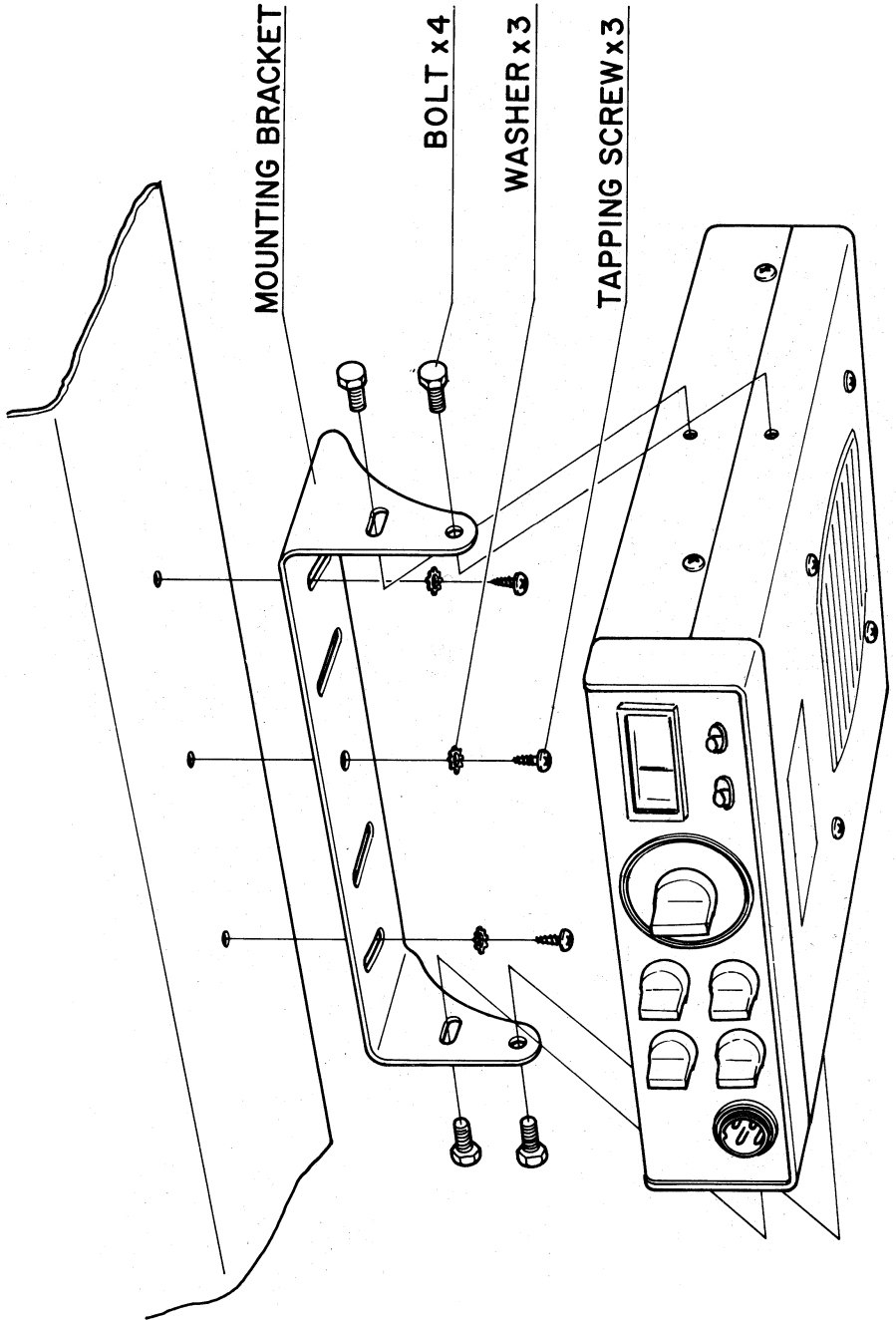

CAUTION: Before operating this transceiver, you are required by law to read and understand Part 95 of the FCC Rules and Regulations.

Check to see if the proper connections have been made on the power cable, antenna system and microphone.

1. RECEIVER

- (a) Turn all rotary controls counter clockwise.
- (b) Put PA-CB switch to CB position.
- (c) Put ANL-OFF Switch to ANL position.

- (d) Turn the ON-OFF switch (on the volume control) to the "ON" position.
- (e) Turn RF Gain control fully clockwise.
- (f) Select the desired operating channel (1-23).
- (g) Set the Delta Tune switch to its center position.
- (h) Advance the Volume control to normal listening levels.
- (i) Adjust the squelch control.
- (j) When signal is heard, adjust the Delta Tune for maximum "S" meter reading.

TRANSMITTER

IT IS ILLEGAL TO OPERATE THE TRANSMITTER SECTION OF THIS TRANSCEIVER PRIOR TO RECEIVING A VALID STATION LICENSE AND CALL SIGN.

TO TRANSMIT:

CAUTION: Never operate this unit without an adequate antenna system or load as damage may result.

1. Select the desired channel.
2. Depress the push-to-talk switch on the microphone and talk in a normal voice level.

The technical information, diagrams and charts provided in this manual are supplied for the use of a qualified holder of a first or second class radiotelephone license in servicing this transceiver. It is the users responsibility to see that this unit is operating at all times in accordance with the F.C.C. citizens radio service regulations.

If you install your own transceiver, do not attempt to make any transmitter tuning adjustment. Adjustments are prohibited by the F.C.C. unless you hold or are in the presence and under the supervision of a first or second class radiotelephone licensed person. A Citizens Band or Amateur license is not sufficient.

CRYSTAL FREQUENCY CHART

(A) Group 6 pcs.

X ¹	37.60 MHz
X ²	37.65 MHz
X ³	37.70 MHz
X ⁴	37.75 MHz
X ⁵	37.80 MHz
X ⁶	37.85 MHz

(B) Group 4 pcs.
(Transmitting)

X ⁷	10.635 MHz
X ⁸	10.625 MHz
X ⁹	10.615 MHz
X ¹⁰	10.595 MHz

(C) Group 4 pcs.
(Receiving)

X ¹¹	10.18 MHz
X ¹²	10.17 MHz
X ¹³	10.16 MHz
X ¹⁴	10.14 MHz

CHANNEL	FREQUENCY (MHz)	Combination (Transmit)	Combination (Receive)
1.	26.965	X ¹ -X ⁷	X ¹ -X ¹¹
2.	26.975	X ¹ -X ⁸	X ¹ -X ¹²
3.	26.985	X ¹ -X ⁹	X ⁴ -X ¹³
4.	27.005	X ¹ -X ¹⁰	X ¹ -X ¹⁴
5.	27.015	X ² -X ⁷	X ² -X ¹¹
6.	27.025	X ² -X ⁸	X ² -X ¹²
7.	27.035	X ² -X ⁹	X ² -X ¹³
8.	27.055	X ² -X ¹⁰	X ² -X ¹⁴
9.	27.065	X ³ -X ⁷	X ³ -X ¹¹
10.	27.075	X ³ -X ⁸	X ³ -X ¹²
11.	27.085	X ³ -X ⁹	X ³ -X ¹³
12.	27.105	X ³ -X ¹⁰	X ³ -X ¹⁴
13.	27.115	X ⁴ -X ⁷	X ⁴ -X ¹¹
14.	27.125	X ⁴ -X ⁸	X ⁴ -X ¹²
15.	27.135	X ⁴ -X ⁹	X ⁴ -X ¹³
16.	27.155	X ⁴ -X ¹⁰	X ⁴ -X ¹⁴
17.	27.165	X ⁵ -X ⁷	X ⁵ -X ¹¹
18.	27.175	X ⁵ -X ⁸	X ⁵ -X ¹²
19.	27.185	X ⁵ -X ⁹	X ⁵ -X ¹³
20.	27.205	X ⁵ -X ¹⁰	X ⁵ -X ¹⁴
21.	27.215	X ⁶ -X ⁷	X ⁶ -X ¹¹
22.	27.225	X ⁶ -X ⁸	X ⁶ -X ¹²
23.	27.255	X ⁶ -X ¹⁰	X ⁶ -X ¹⁴

WARNING: ANY CHANGE OF CRYSTALS OR OTHER COMPONENTS WHICH WOULD RESULT IN VIOLATIONS OF THE FCC TECHNICAL REQUIREMENTS MUST NOT BE MADE. THESE UNAUTHORIZED CHANGES WILL VOID TYPE ACCEPTANCE OF THIS UNIT.

FCC LICENSE

Your new BETA ACT-2000 is a combination receiver-transmitter designed and built for licensed Class D operation on any of the 23 frequencies designated as citizens band channels by the Federal Communications Commission. Before transmitting with your ACT-2000, it is essential that you acquire an FCC Class D Citizens Radio Service license. A license application form #505 can be obtained from the Federal Communications Commission, Washington, D. C. 20554 or from the nearest FCC field office listed below. Complete the form and mail with \$4.00 to:

Federal Communications Commission
Gettysburg, Pennsylvania 17325

It is also a requirement to read and know Part 95 of the FCC Rules and Regulations that apply to the operation of a Class D Citizens Band unit. Copies of this regulation can be obtained from the Federal Communications Commission, Washington, D. C. 20554, or from the FCC Field Office nearest your home:

Mobile, Ala. 36602
Anchorage, Alaska 99501
Los Angeles, Cal. 90014
San Diego, Cal. 92101
San Francisco, Cal. 94126
San Pedro, Cal. 90731
Denver, Col. 80202
Miami, Fla. 33101
Tampa, Fla. 33606
Atlanta, Ga. 31402
Savannah, Ga. 31502
Honolulu, Hawaii 96808
Chicago, Ill. 60604
New Orleans, La. 70130
Baltimore, Md. 21202

Boston, Mass. 02109
Detroit, Mich. 48266
St. Paul, Minn. 55102
Kansas City, Mo. 64106
Buffalo, N.Y. 14203
Portland, Ore. 97205
Philadelphia, Pa. 19106
San Juan, P.R. 00903
Beaumont, Tex. 77704
Dallas, Tex. 75202
Houston, Tex. 77002
Norfolk, Va. 23510
Seattle, Wash. 98104
New York, N.Y. 10014

KRYPTON ELECTRONICS, INC. HEREBY CERTIFIES THAT THIS EQUIPMENT HAS BEEN DESIGNED, MANUFACTURED AND FURNISHED IN ACCORDANCE WITH VOL, 6 PART 95 OF THE CURRENT FCC RULES AND REGULATIONS FOR CLASS D CITIZENS BAND OPERATION.

LIMITED WARRANTY POLICY

Krypton products are built to rigid specifications and are quality audited at several stages in their manufacturing. We warrant each new Krypton product to be free from defects in material and craftsmanship for a period of 90 days under normal use. We will repair free of charge or replace at no charge any unit which our examination shall disclose to be defective and under warranty. This warranty shall be valid only where a purchaser has filled in and has on file at the factory a warranty registration card (supplied with all units). If no warranty card is on file, a sales receipt showing the date of purchase must accompany the article being returned.

This warranty is invalid for any Krypton product which has been subject to misuse, neglect, accident, modifications in wiring not of our own installation, or to the use in violation of instructions furnished by us. It is also not applicable to units which have been modified or repaired outside our factory.

This warranty does not cover any accessory used in connection with the product.

Should in warranty repair be required, carefully pack the unit and ship it, insured prepaid, to the address listed below. Enclose \$12.50 to cover return postage and handling.

This limited warranty is in lieu of all other warranties expressed or implied, and no representative or person is authorized to assume for us any other liability in connection with the sale of our products.

KRYPTON ELECTRONICS, INC.
18 Mileed Way Avenel, N. J. 07001

BLOCK DIAGRAMS

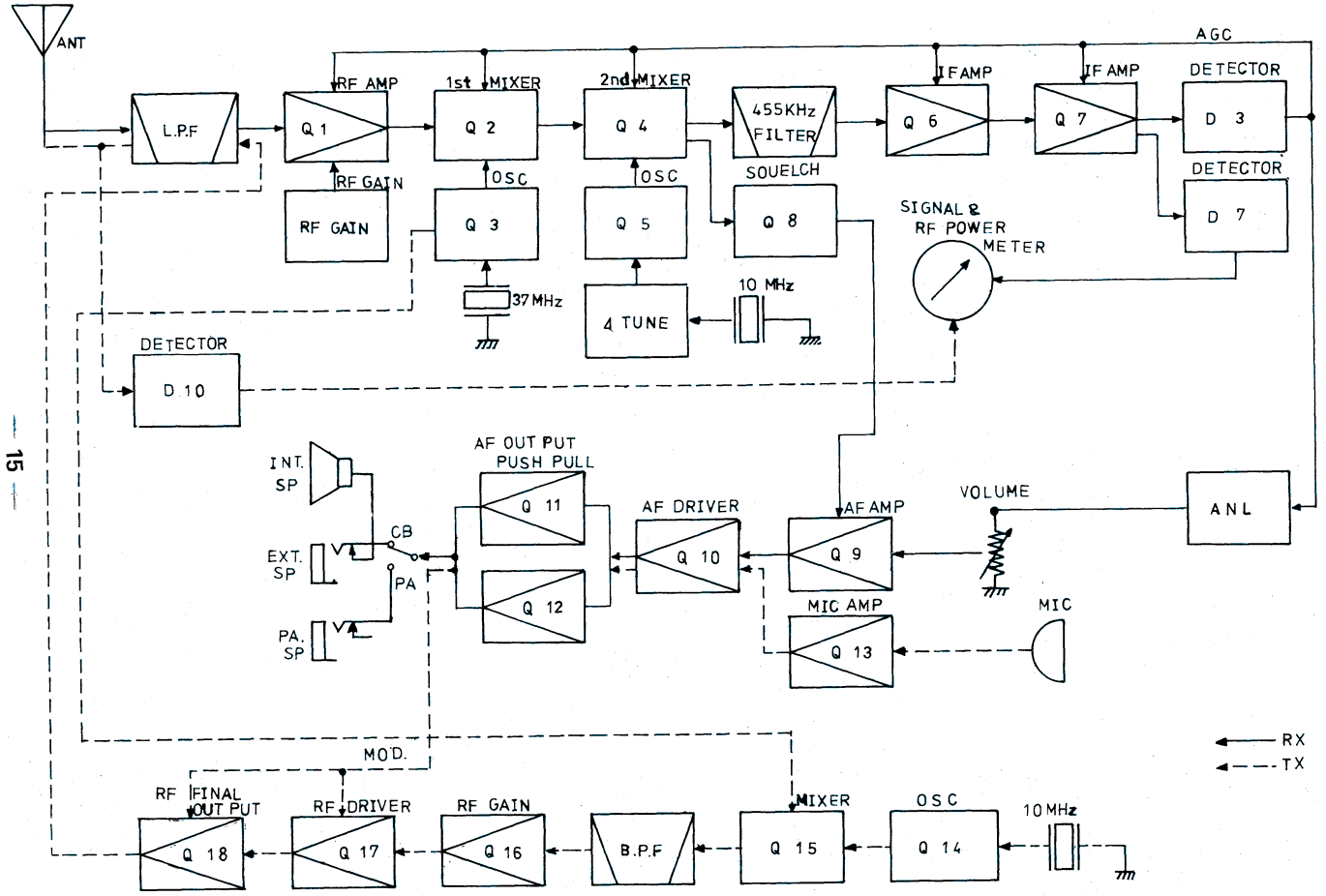

← RX
 - - - TX

TOP VIEW

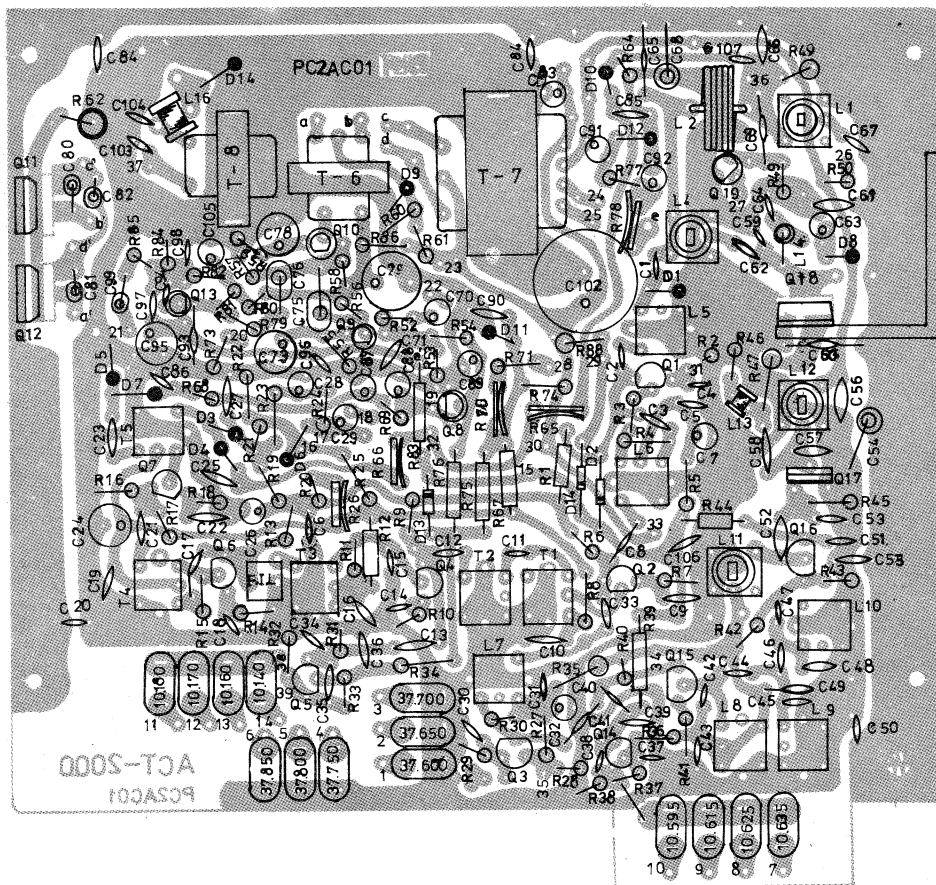

PARTS LAYOUT

BACK VIEW

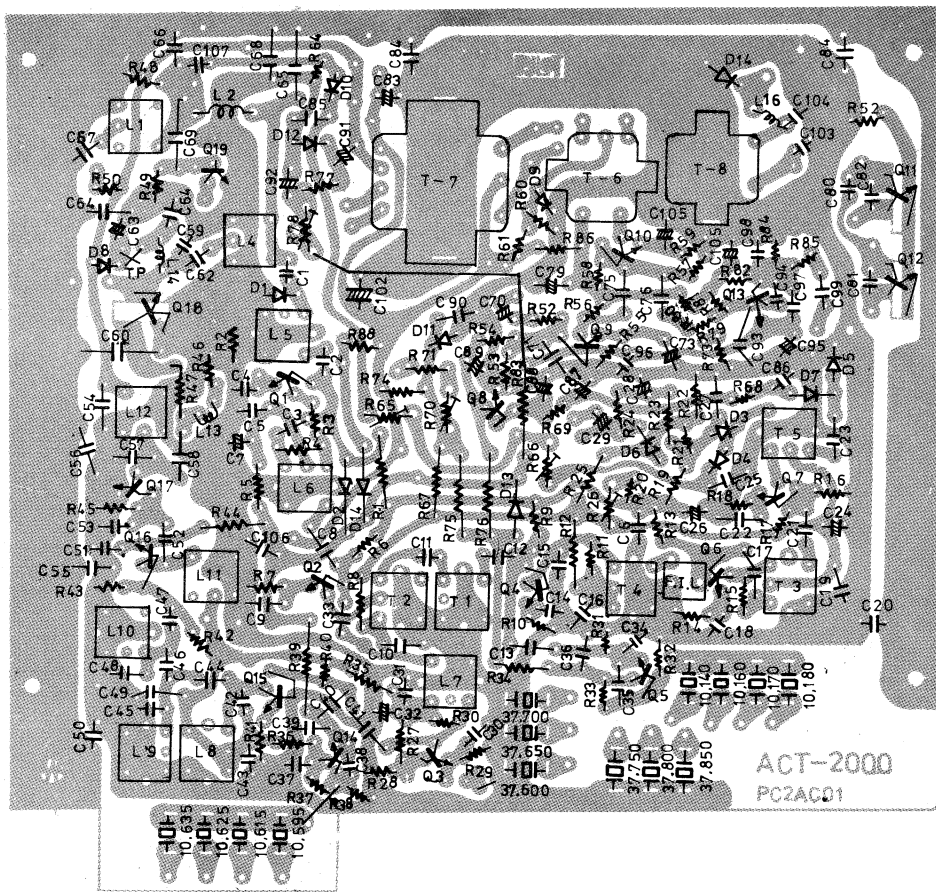

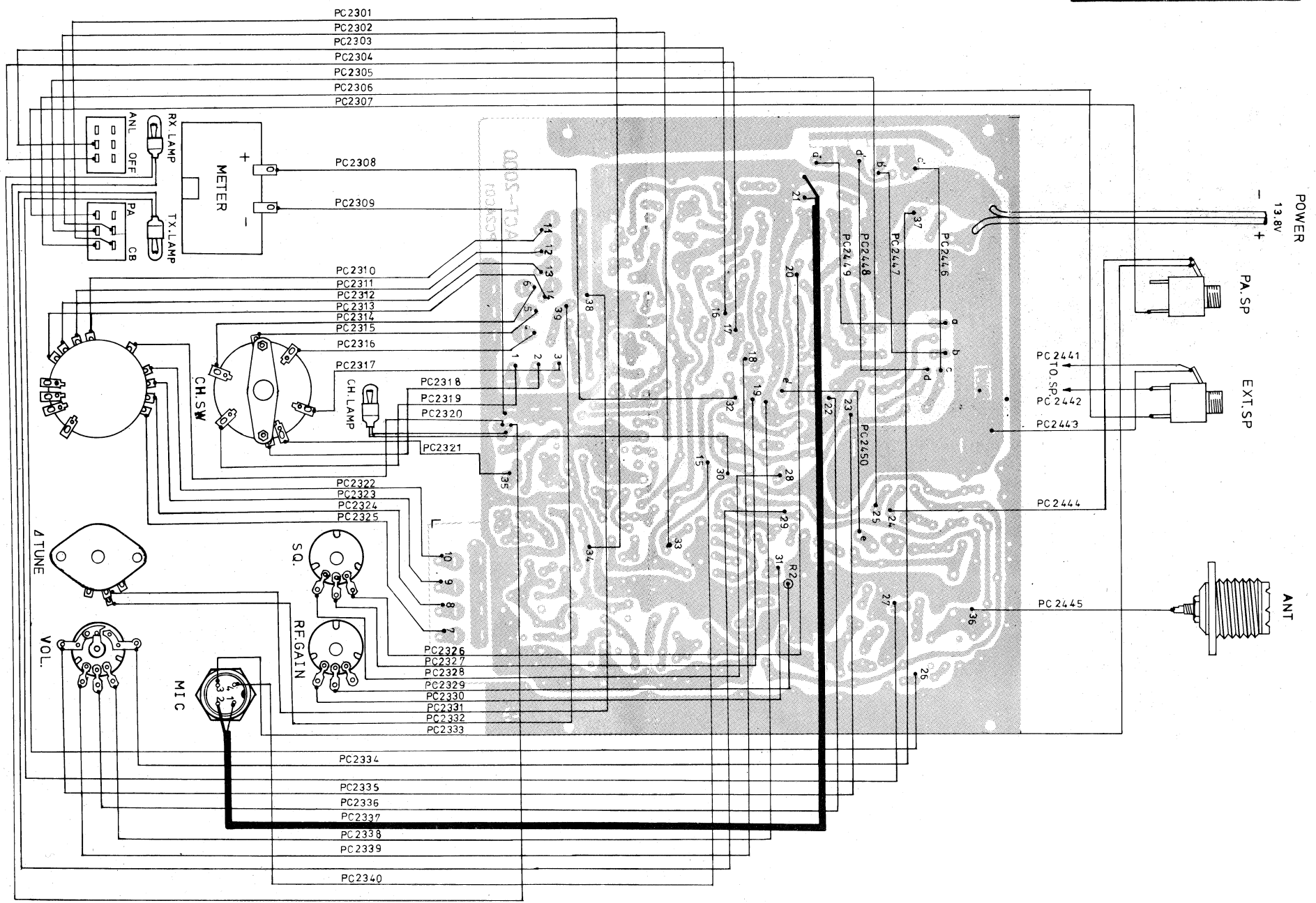

SCHEMATIC DIAGRAM

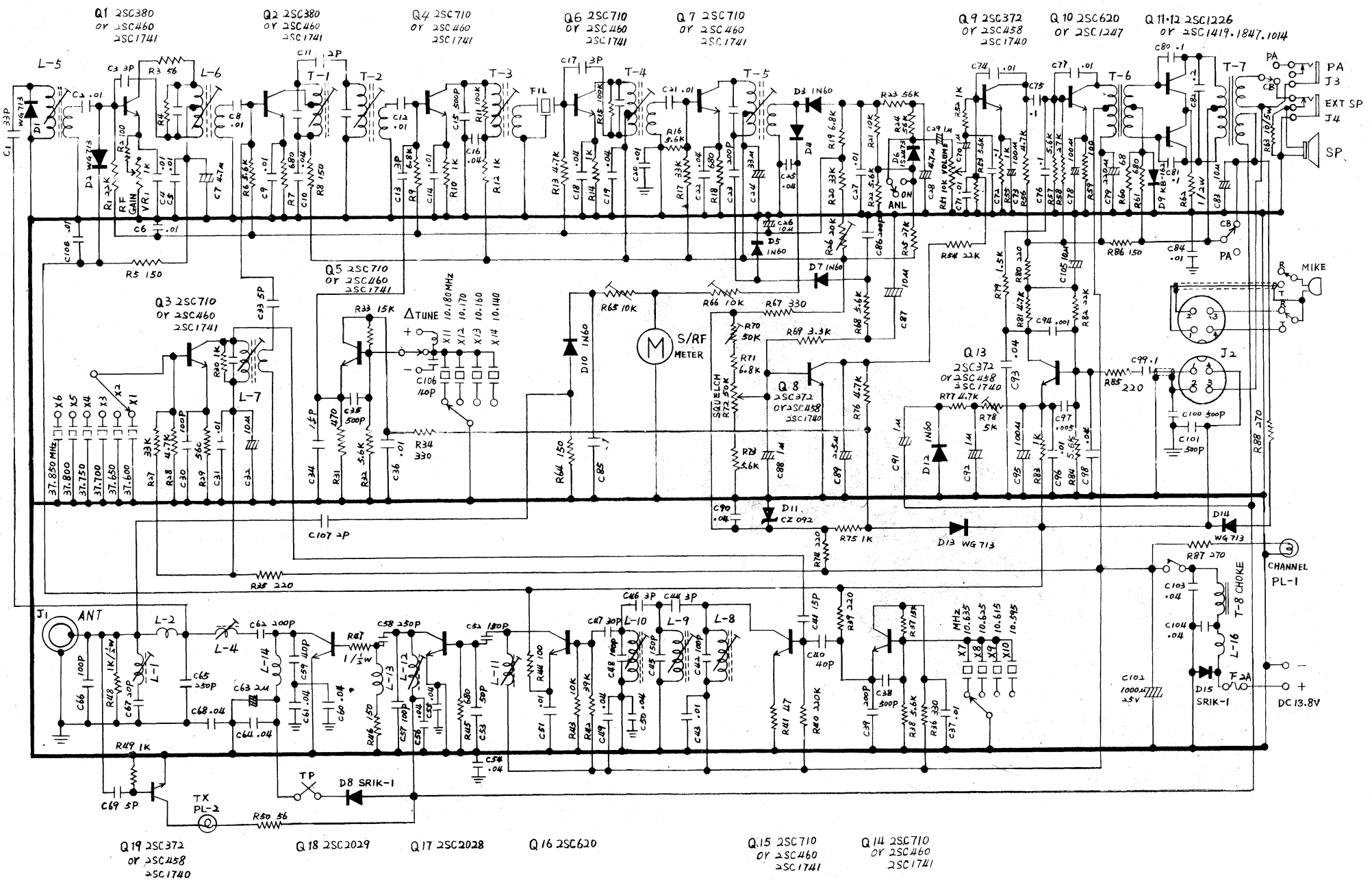

Q1 2SC380
OR 2SC460
2SC1741

Q2 2SC380
OR 2SC460
2SC1741

Q4 2SC710
OR 2SC460
2SC1741

Q6 2SC710
OR 2SC460
2SC1741

Q7 2SC710
OR 2SC460
2SC1741

Q9 2SC372
OR 2SC458
2SC1740

Q10 2SC620
OR 2SC1247

Q11-12 2SC1226
OR 2SC1419, 1847, 1014

Q3 2SC710
OR 2SC460
2SC1741

Q5 2SC710
OR 2SC460
2SC1741

Q8 2SC372
OR 2SC458
2SC1740

Q13 2SC372
OR 2SC458
2SC1740

Q19 2SC372
OR 2SC458
2SC1740

Q18 2SC2029

Q17 2SC2028

Q16 2SC620

Q15 2SC710
OR 2SC460
2SC1741

Q14 2SC710
OR 2SC460
2SC1741