

**REALISTIC<sup>®</sup>**

# Service Manual

21-1561

21-9448

**TRC-448**

## **40-CHANNEL MOBILE TRANSCEIVER**

Catalog Number: 21-1561



CUSTOM MANUFACTURED FOR RADIO SHACK  A DIVISION OF TANDY CORPORATION

# CONTENTS

SPECIFICATIONS .....	3, 4
BLOCK DIAGRAM .....	5
PRINCIPLES OF OPERATION .....	6 ~ 8
DISASSEMBLY .....	9
ALIGNMENT PREPARATION .....	9
ALIGNMENT POSITIONS AND POINTS .....	10
PLL SECTION ALIGNMENT CHART .....	11
VCO OUTPUT FREQUENCY, IC-2 INPUT FREQUENCY AND CODE TABLE .....	12
TRANSMITTER SECTION ALIGNMENT CHART .....	13
RECEIVER SECTION ALIGNMENT CHART .....	14
ALIGNMENT CONNECTIONS .....	15, 16
NOISE BLANKER ALIGNMENT CHART .....	17
PLL P.C. BOARD TOP VIEW .....	18
PLL P.C. BOARD BOTTOM VIEW .....	19
MAIN P.C. BOARD TOP VIEW .....	20
MAIN P.C. BOARD BOTTOM VIEW .....	21
WIRING DIAGRAM (1) .....	22
WIRING DIAGRAM (2) .....	23
LED P.C.BOARD (TOP VIEW) .....	24
LED P.C.BOARD (BOTTOM VIEW) .....	24
LED P.C.BOARD/ CHANNEL SWITCH P.C.BOARD WIRING DIAGRAM.....	24
TROUBLESHOOTING .....	25 ~ 27
SEMICONDUCTOR VOLTAGE READINGS .....	28 ~ 33
PLL P.C.BOARD ASSEMBLY PARTS LIST .....	34 ~ 39
MAIN P.C.BOARD ASSEMBLY PARTS LIST.....	40 ~ 49
LED P.C.BOARD ASSEMBLY PARTS LIST.....	49
CHASSIS ASSEMBLY PARTS LIST .....	50
EXPLODED VIEW .....	51
SCHEMATIC DIAGRAM.....	52, 53
SEMICONDUCTOR LEAD IDENTIFICATION.....	54
IC PIN CONFIGURATION .....	54, 55

# SPECIFICATIONS

DESCRIPTION		CONDITION	NOMINAL	LIMIT
<b>TRANSMITTER</b>				
Frequency Tolerance	AM		±0.0003%	±0.005%
	SSB		±0.0003%	±0.005%
RF Output	AM	13.8 V DC	3.8 W (4 watts max.)	3.5 ~ 4.0 W
	SSB	13.8 V DC	12 W PEP	10 ~ 12 W
Modulation Distortion		80% MOD 1 kHz	3%	10%
Spurious Harmonic Emission	AM		-65 dB	-60 dB
	SSB		-65 dB	-60 dB
Carrier Suppression	SSB		-50 dB	-40 dB
Unwanted Sideband Suppression		2.5 kHz (SSB)	-50 dB	-40 dB
Current Drain		No Modulation (AM)	1500 mA	2000 mA
		(SSB)	1000 mA	1500 mA
		80% MOD (AM)	2000 mA	2600 mA
		10 W PEP Two-Tone (SSB)	2500 mA	3000 mA
Modulation Frequency Response		1 kHz 0 dB		
		Lower 450 Hz	AM SSB -6 dB	AM -10 dB SSB -14 dB
		Upper 2.5 kHz	AM SSB -6 dB	AM SSB -10 dB
Carrier Power Uniformity		Ch-to-Ch with No MOD	AM 0.3 W	0.5 W
MIC Input Level Uniformity		Ch-to-Ch for 4 W Output,	SSB 2 dB	3 dB
		1000Hz Single-Tone		
Intermodulation Distortion		500 and 2500 Hz Two-Tone	30 dB	25 dB
MIC Input Level Uniformity		LSB/USB 4 W Output		
		1.5 kHz Single Tone	1 dB	3 dB
Microphone Sensitivity		AM 50% MOD	0.7 mV	1.5 mV
		SSB 4 W PEP	0.7 mV	1.5 mV
AMC Range		AM 50 ~ 100% MOD	50 dB	30 dB
		SSB 10 ~ 12 W PEP	20 dB	10 dB
<b>RECEIVER</b>				
Max. Sensitivity		AM	0.5 μV	1 μV
		SSB	0.25 μV	0.5 μV
Sensitivity		10 dB S/N AM	0.5 μV	1 μV
		SSB	0.25 μV	0.5 μV
AGC Figure of Merit		50 mV 10 dB AM	90 dB	80 dB
		SSB	90 dB	80 dB
Overload AGC Characteristics		10 mV to 100 mV AM	±2 dB	±5 dB
		SSB	±2 dB	±5 dB
Overall Audio Fidelity		at 6 dB Down		
		Upper Frequency AM	2100 Hz	1750 ~ 2500 Hz
		SSB	3500 Hz	1750 ~ 2500 Hz
		Lower Frequency AM	300 Hz	150 ~ 500 Hz
		SSB	300 Hz	150 ~ 500 Hz
Cross Modulation RS Standard		AM	60 dB	50 dB
Adjacent Channel Selectivity		10 kHz AM	80 dB	60 dB
		SSB	90 dB	60 dB
Maximum Audio Output Power		AM	5 W	4 W
		SSB	5 W	4 W
Audio Output Power		10% THD SSB	3.5 W	3 W
		AM	3.5 W	3 W
THD AM		500 mW Output 1 mV Input 30% (MOD)	3%	6%
		80% (MOD)	5%	12%
THD SSB		1 mV Input 1 kHz Single Tone	3%	6%

DESCRIPTION	CONDITION	NOMINAL	LIMIT
RF Gain Control Range at Max.	AM	40 dB	30 ~ 50 dB
Sensitivity Level	SSB	40 dB	30 ~ 50 dB
S/N Ratio	AM Input 1 mV	40 dB	35 dB
	SSB	40 dB	35 dB
Squelch Sensitivity at Threshold	AM	0.5 $\mu$ V	1 $\mu$ V
	SSB	0.5 $\mu$ V	1 $\mu$ V
Squelch Sensitivity at Tight	AM	1000 $\mu$ V	500 ~ 2000 $\mu$ V
	SSB	1000 $\mu$ V	500 ~ 2000 $\mu$ V
Skirt Rejection ( $\pm$ 20 kHz)	AM	80 dB	70 dB
S Meter Sensitivity at "S-9" (No Modulation AM)	AM	100 $\mu$ V	50 ~ 200 $\mu$ V
	SSB	100 $\mu$ V	50 ~ 200 $\mu$ V
Image Rejection Ratio	AM	80 dB	65 dB
fo + (2 x 7.8 MHz)	SSB	80 dB	65 dB
1/2 IF Rejection Ratio	AM	90 dB	80 dB
fo + 7.8 MHz/2	SSB	90 dB	80 dB
IF Rejection Ratio 7.8 MHz	AM	90 dB	75 dB
	SSB	90 dB	75 dB
Oscillator Drop-out Voltage	AM	7 V	10 V
	SSB	7 V	10 V
Current Drain at No Signal	AM	550 mA	1000 mA
	SSB	550 mA	1000 mA
Current Drain at Maximum	AM	1000 mA	1500 mA
	SSB	1000 mA	1500 mA
Clarifier Range	AM	$\pm$ 1 kHz	$\pm$ 0.6 ~ $\pm$ 2.5 kHz
	SSB	$\pm$ 1 kHz	$\pm$ 0.6 ~ $\pm$ 2.5 kHz
Spurious Rejection Ratio			
Within Band	AM	65 dB	56 dB
	SSB	65 dB	56 dB
Outside of Band	AM	60 dB	50 dB
	SSB	60 dB	50 dB
<b>PUBLIC ADDRESS</b>			
Microphone Sensitivity	3 W Output 1 kHz	1 mV	2 mV
Output Power	10% Distortion	3.5 W	3 W
Current Drain	No Signal	500 mA	1000 mA
	Max. Output Power	1000 mA	1500 mA
<b>GENERAL</b>			
Frequency Range	29.965 to 27.405 MHz		
Channel	40 Channels		
Frequency Control	Crystal Control (PLL System)		
Operating Temperature	$-10^{\circ}$ C to $50^{\circ}$ C		
Humidity	10 to 95%		
Microphone	Dynamic Type with PTT Switch		
Operating Voltage	13.8 V DC Nominal (12.0 ~ 15.0 Volt DC)		
Power Consumption	Pos./Neg. Ground 40 Watts		
Meter	TX Power and Signal Strength		
Size	205(W) x 60(H) x 260(D) mm (8-1/4" x 2-1/2" x 10-1/2")		

NOTE: Nominal Specs represent <sup>the</sup> design specs: all units should be able to approximate these – some will exceed and some may drop slightly below these specs. Limit Specs represent the absolute worst condition which still might be considered acceptable; in no case should a unit perform to less than within any Limit Spec.

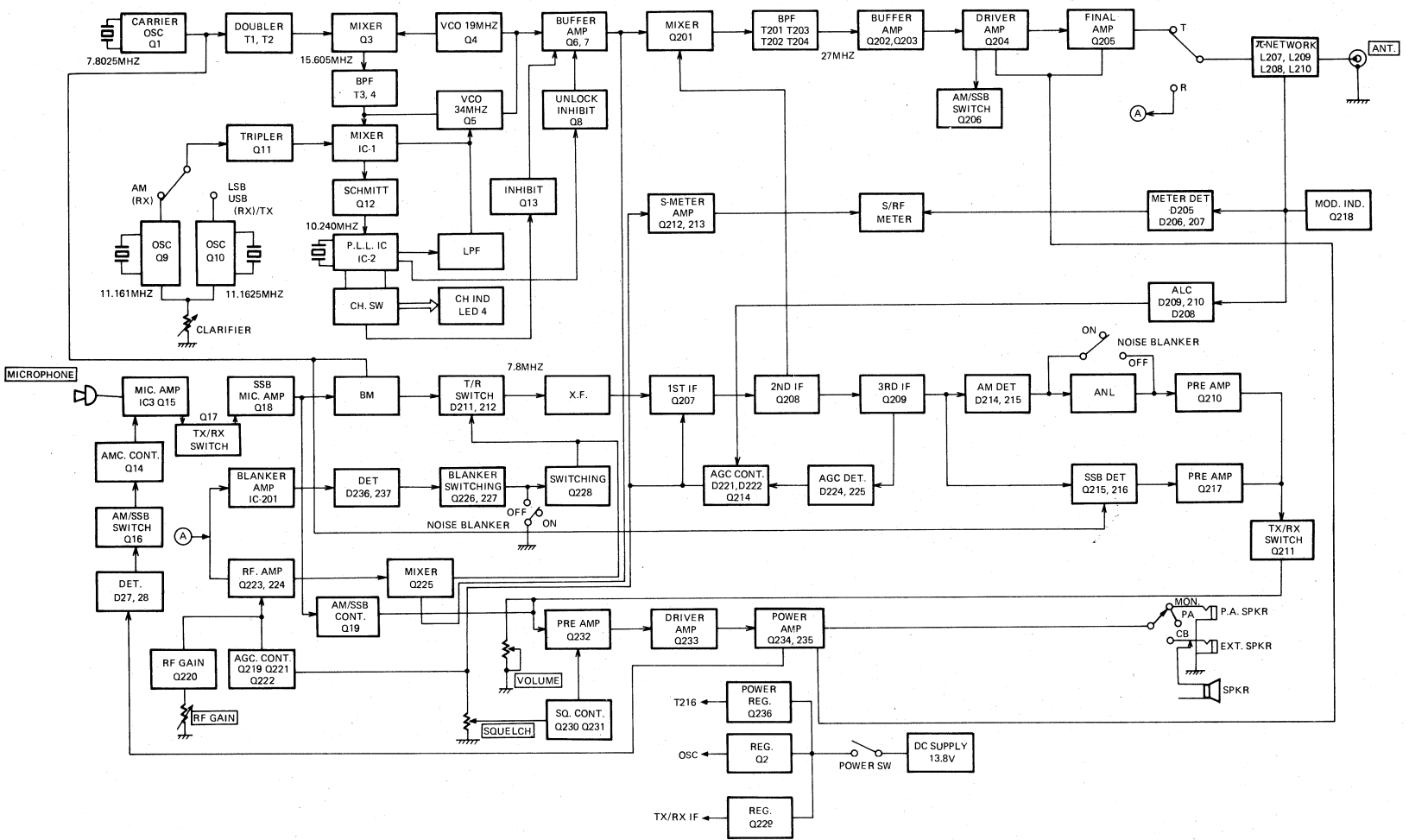

# PRINCIPLES OF OPERATION

This section of the Service Manual will give you a brief technical description of unique or special circuits which you might otherwise not understand, notice or be able to troubleshoot.

## PLL CIRCUIT

The TRC-448 uses a Digital Phase Lock Loop circuit to synthesize each of the channel frequencies. The PLL Circuit consists of a reference crystal oscillator (10.24 MHz), reference divider, programable divider, crystal oscillator, Phase Detector, Low Pass Filter (LPF) and a Voltage Controlled Oscillator (VCO, which uses a varicap diode as the frequency control source).

Refer to the AM and USB Block Diagram as you go through the following description. A 10.24 MHz Crystal is used as a reference frequency. The crystal is connected between Pin 4 and 5 of the PLL IC IC-2.

Crystal oscillator Q10 produces a 33.4875/3 MHz frequency signal. This signal is processed through Q11 tripler and mixed by IC-1 mixer with the Q5 VCO frequency (34.7675 to 35.2075 MHz). The resulting down-mix produces signals of 1.28 through 1.72 MHz, which pass through LPF, and Q12 amplifier and then applied to Pin 3 of PLL IC IC-2. These frequencies are divided by "N" (128 through 172) as determined by the Channel Selector switch. Thus the output is 10 kHz (divided internally by IC-2).

Also, the reference oscillator frequency, 10.24 MHz, is divided by 1024 (again, internally by IC-2) resulting in another 10 kHz frequency.

These two 10 kHz signals are fed to the Phase Detector and AFC. An error voltage is generated by the Phase Detector which is in proportion to the phase difference between these two 10 kHz signals. This error voltage appears at Pin 7. The AFC circuit brings the VCO to within the lock range of the Phase Detector. The AFC output is a tri-state output that is open when the circuit is in phase lock, provides positive going pulses when the VCO frequency is lower than the reference frequency and provides negative going pulses when the VCO frequency is higher than the reference frequency. This error voltage appears at Pin 1. The error voltage which appears at Pin 7 and 1 are the result of the phase difference, plus effects of harmonics and extraneous noise. These error voltages pass through the LPF, where the error voltage is integrated and harmonics and noises are filtered out. The resulting DC voltage is applied to the VCO (a varicap diode) whose capacity varies with applied DC voltage. With proper circuit design and precise adjustments, the VCO frequency is accurate and precise. When the Phase Detector senses no frequency or phase difference between the two 10 kHz signals, the system is "locked" and the VCO generates a frequency which is as accurate and stable as the reference crystal oscillator.

The Channel Selector switch provides a Binary Code output which is connected to Pins 9 through 16. The resulting code determines "N", the divisor which produces the required output frequency for each channel (precisely spaced 10 kHz apart).

For AM Receive Mode, crystal oscillator Q9 generates a frequency of 33.485/3 MHz. This signal is also processed through Q11 tripler and mixed in IC-1 mixer with the Q5 VCO frequency (34.765 to 35.205 MHz). The resulting down-mix produces 1.28 through 1.72 MHz frequencies which are supplied to Pin 3 of IC-2. Thus, the circuit functions in the same way, except for the method of deriving the required 1.28 through 1.72 MHz stepped frequencies.

For LSB, crystal oscillator Q10 generates a frequency of 33.4875/3 MHz. This signal is processed through Q11 tripler. Carrier oscillator Q1 produces a 7.8025 MHz signal. This signal is processed through T1 and T2 Band Pass Filter, tuned to the 2nd harmonic (15.605 MHz) and mixed in Q3 mixer with the Q4 VCO frequency (19.1625 to 19.6025 MHz). The resulting up-mix produces 34.7675 through 35.2075 MHz which pass through BPF and mixed in IC-1 mixer with the 33.4875 MHz. The resulting down-mix produces the 1.28 through 1.72 MHz frequencies which are supplied to Pin 3 of IC-2. Thus, the circuit functions in the same way, except for the method of deriving the required 1.28 through 1.72 MHz stepped frequencies.

At Pin 8 of IC-2 a Transmit Inhibit signal is available. It provides a high output (supply voltage to IC-2) when the synthesizer attains a lock condition, or a low (0 volt) when not in lock. When the output is either high or low, no phase error pulses are outputted that require detection. This circuit is used to inhibit transmitter operation if the programmed frequency cannot be properly acquired. The lock detector output will go low if a frequency error exists for more than 0.5 milliseconds. This signal is applied to the base of Q8, turning it on or off. Thus the Transmitter can not operate in an unlocked condition of the PLL. The channel selector switch also has an inhibit function, when the selector switch is set in between two channel positions, Q13 is turned on to kill Q6.

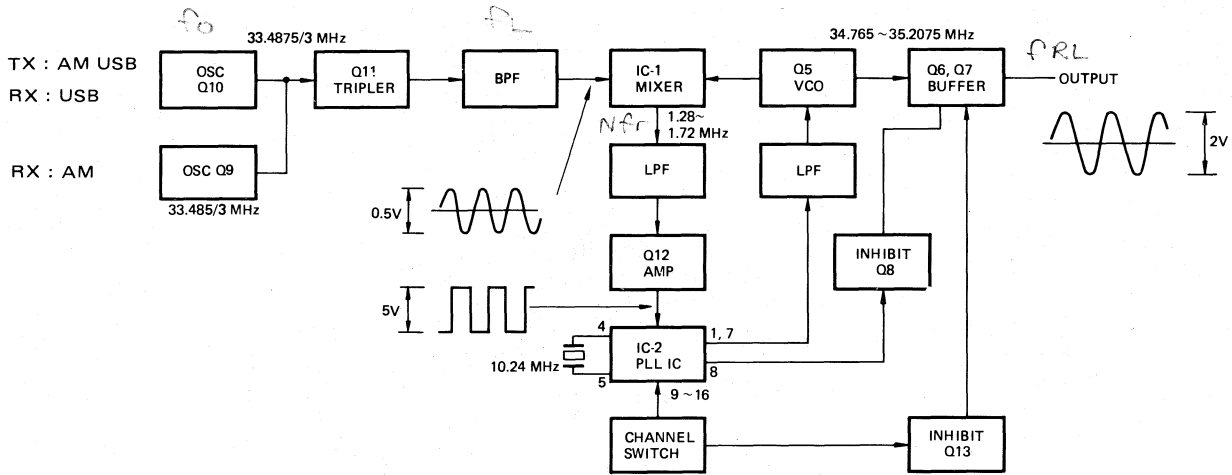

**AM and USB**  
**(Receive and Transmit)**

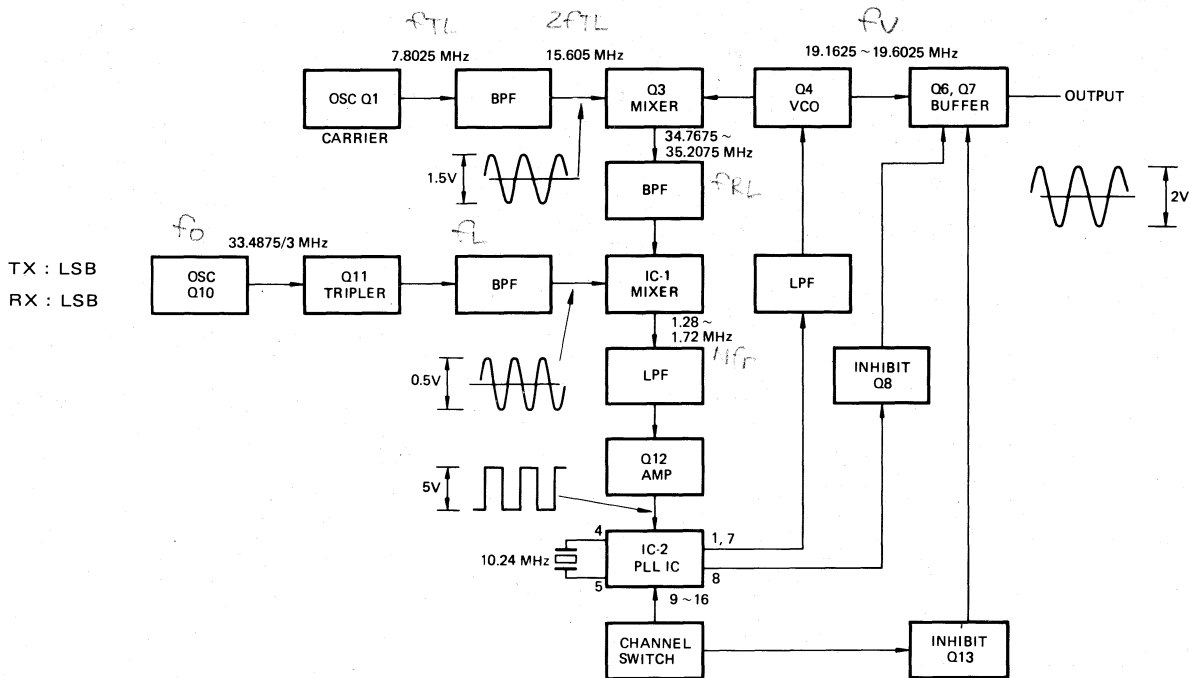

**LSB**  
**(Receive and Transmit)**

## AUTOMATIC MODULATION CONTROL CIRCUIT

The Automatic Modulation Control (AMC) circuit consists of Q14, D26, D27 and D28. The Mic input signal is fed to pin 4 of the microphone jack and then through R62, C84 to the input terminal (pin 5) of IC-3 where it is amplified and delivered through C90 and VR4 for further amplification by Q15, Q232, Q233, Q234 and Q235. The Audio amplifier/Modulation amplifier drives T216, whose secondary incorporates C104, through D228 and R280, which couples a portion of the signal to AMC detector diodes D27 and D28. D26 (an 8-volt zener) is connected to the output of D27/28; when the detected DC voltage from D27/28 exceeds 8 volts, D26 conducts. This applies a DC voltage to the base of Q14, thus decreasing its collector impedance. Notice that the combination of Q14 and VR4 automatically sets the desired audio signal level processed by the audio amplifier circuitry. VR5 is adjusted to set a modulation level of less than 100%.

VR4 is adjusted to set a modulation level in the SSB mode. IC-3 is a silicon integrated circuit which functions as a audio amplifier with built-in automatic voice-operated gain adjustment. It is designed to provide an essentially constant output signal for a 60 dB range of input.

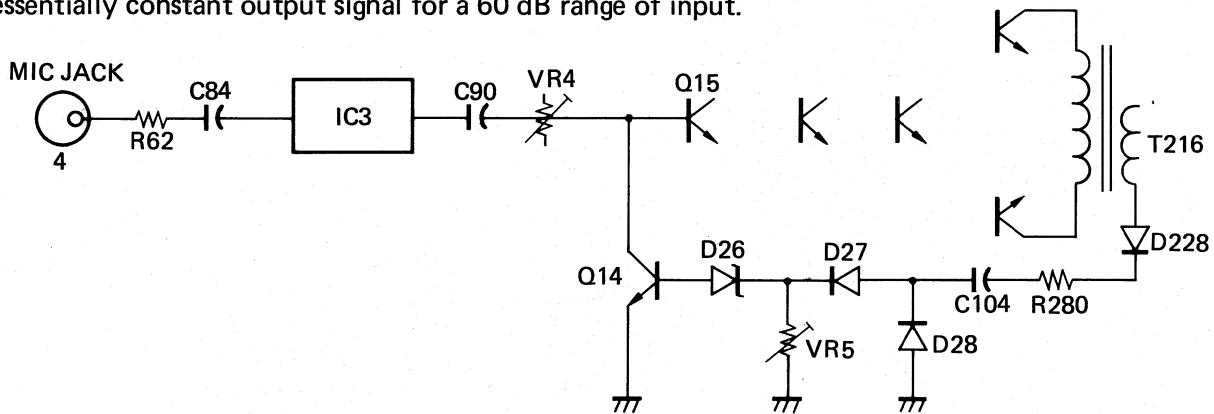

## AUTOMATIC LIMITER CONTROL (TRANSMITTER)/AUTOMATIC GAIN CONTROL (RECEIVER)

The Automatic Limiter Control (ALC) circuit consists of D209, D210 and Q214. The RF output signal is detected by D209 and D210. This applies a negative DC voltage to the gate of Q214, thus decreasing its source voltage. This source voltage controls Q207's (7.8 MHz amplifier) base bias voltage, thus decreasing its base voltage. This automatically sets the desired RF output level processed by the RF amplifier circuitry. VR207 is adjusted to set a RF power level of less than 12 watts PEP.

Q214 is also used as an automatic gain control (AGC). AGC circuit consists of Q214, D221 and D222. The amplified IF signal is detected by D221, D222, D224, and D225. This voltage is used for fast-attack AGC. D221, D222 and C279 are used for slow-release AGC. Thus, the circuit functions in the same way, except for the delivering of source voltage. VR206 is adjusted to set a "0" reading on the S-meter.

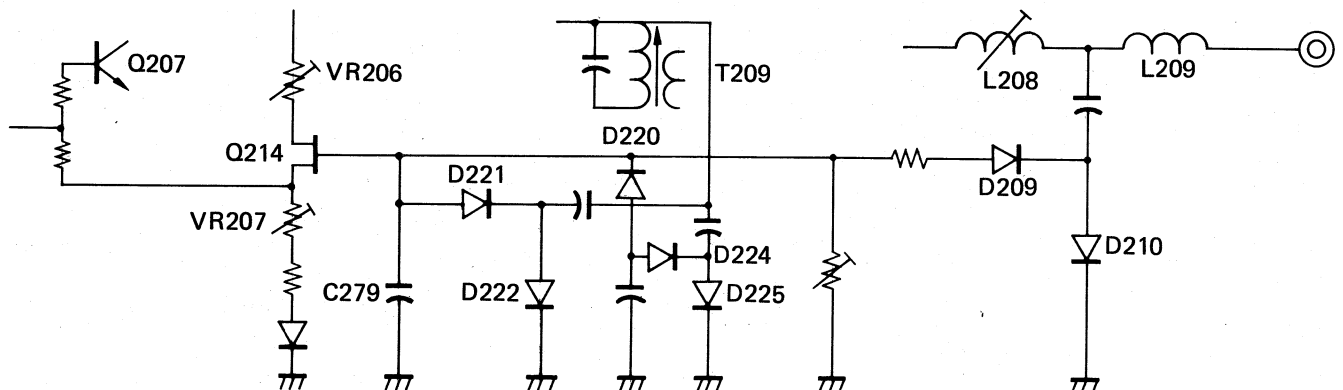

## NOISE BLANKER

Noise pulses are amplified by IC-201 and detected by D236 and D237. The detected pulses are then amplified by Q226 and Q227. This applies a positive pulse to the base of Q228, thus decreasing its collector impedance to shunt the Q225 gate impedance during the duration of the noise pulses. The most objectionable noise pulse frequencies are distributed around 40 MHz, thus T213 and T214 are tuned to this frequency.

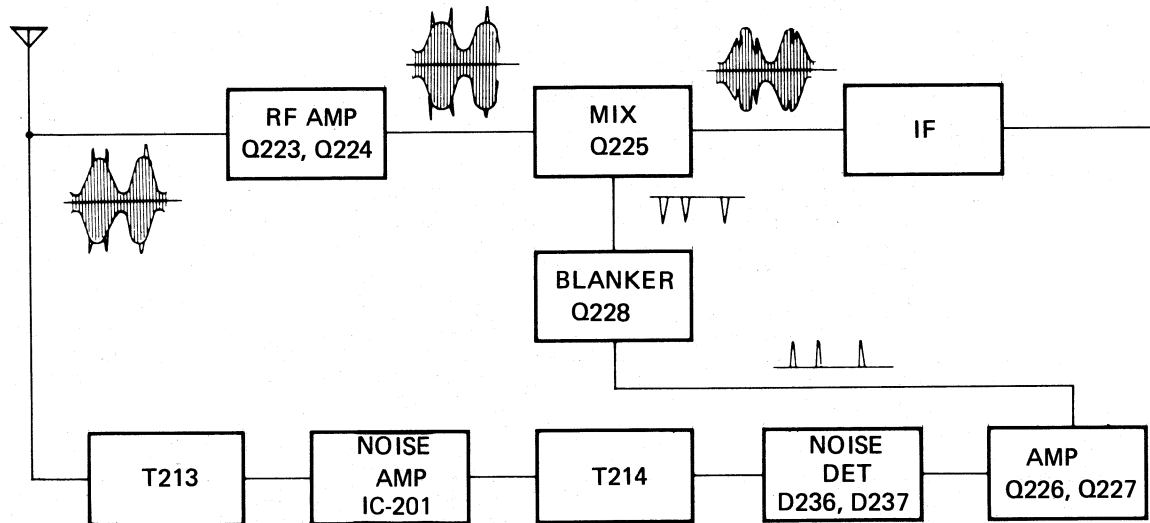

## DISASSEMBLY

Refer to Figure 1.

- Step 1: Remove two bracket screws (A) and the Bracket.
- Step 2: Remove 4 cabinet mounting screws (B) (two from each side).
- Step 3: Remove Cabinet Top and Bottom.

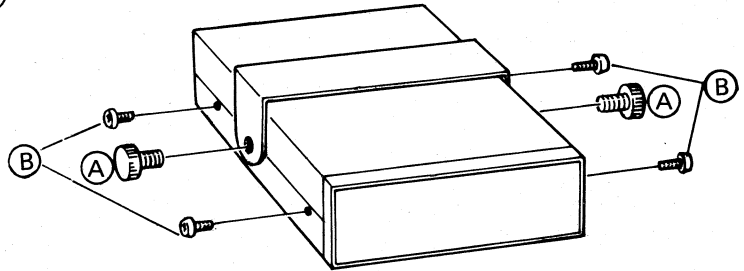

FIGURE 1

## ALIGNMENT PREPARATION

### TEST EQUIPMENT REQUIRED

- 1. Oscilloscope
- 2. AC VTVM
- 3. DC VTVM
- 4. Frequency Counter with level meter
- 5. AUDIO Signal Generator
- 6. Sweep Generator (0 ~ 50 MHz)
- 7. Power meter (50  $\Omega$ )
- 8. 50  $\Omega$ , 10 W dummy load
- 9. 2-tone generator (500 Hz ~ 2.5 kHz)
- 10. RF Signal Generator (0 ~ 30 MHz)
- 11. Pulse Generator
- 12. Monitor Receiver (54 MHz) (or Spectrum Analyzer)

# ALIGNMENT POINTS AND POINTS

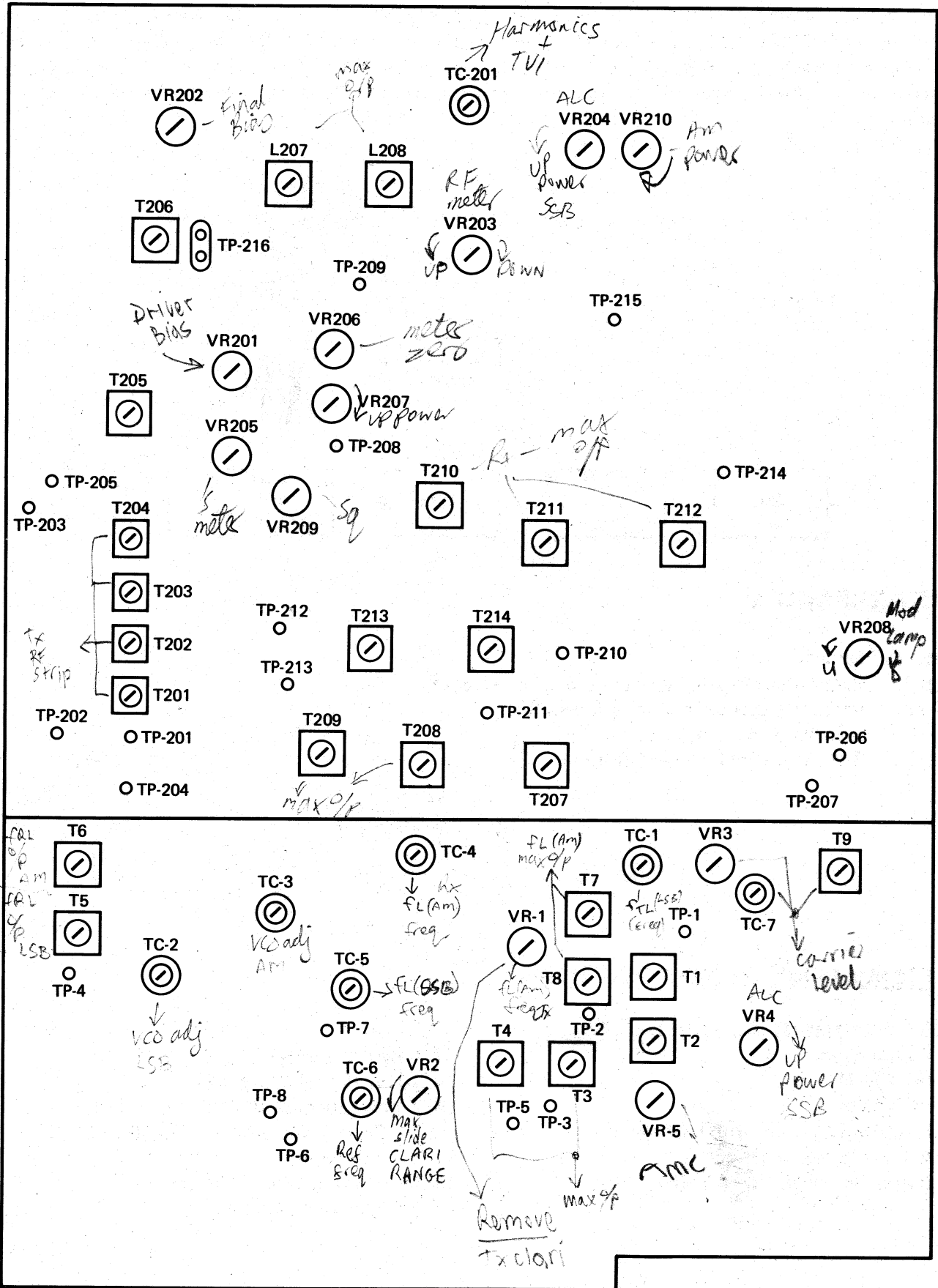

# PLL SECTION ALIGNMENT CHART

Step	Control Setting	Test Equipment	Test Point or Connection	Adjust
1	MODE – RX CH-19 CLARIFIER – Center	DC VTVM	Both ends of VR-304 CLARIFIER Control	VR-2 for 4V DC
2	MODE – RX CH-19	Freq. Counter with with level meter See NOTE 1 below	TP-8	TC-6 for 10.24 MHz ±10Hz
3	MODE – RX (AM)	Freq. Counter with level meter	TP-5	TC-4 for 33.485 MHz T7, 8 for max. output
4	MODE – RX (LSB or USB)	Freq. Counter with level meter	TP-5	TC-5 for 33.4875 MHz
5	MODE – RX (LSB)	Freq. Counter with level metre	TP-1	Check the frequency : 7.8025 MHz
6	MODE – RX (LSB)	Freq. Counter with level meter	TP-2	TC-1 for 7.8025 MHz ±10 Hz T1, T2 for max. output
7	MODE – RX (USB) CH-1	DC VTVM See NOTE 2 below	TP-7	TC-3 for 2.5 V DC ±0.1 V
8	MODE – RX (LSB) CH-19	Freq. Counter with Level Meter	TP-3	T3, T4 34.9875 MHz for max. output
9	MODE – RX (LSB) CH-1	DC VTVM See NOTE 2 below	TP-7	TC-2 for 2.5 V DC
10	MODE – RX (AM) CH-19	Freq. Counter with level meter	TP-4	T6 for max. output at 34.985 MHz
11	MODE – RX (LSB) CH-19	Freq. Counter with level meter	TP-4	T5 for max. output at 19.3825 MHz
12	MODE – TX (AM or USB)	Freq. Counter	TP-5	VR-1 for 33.4875 MHz

**NOTE 1 :** Steps 2 through 12, connect Frequency Counter through a 10 pF Capacitor to the test point noted.

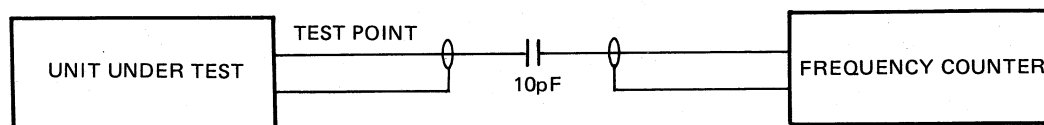

**NOTE 2 :** Steps 7 and 9, DC output should change from  $2.5 \pm 0.1$  volts on CH-1 to approx. 3.5 volts on CH-40.

**NOTE 3 :** You can check the input frequency to IC-2 at TP-6, use TP-7 for ground.

VCO OUTPUT FREQUENCY, IC-2 INPUT FREQUENCY  
AND CODE TABLE

CH	Frequency (MHz)	VCO			N <sub>ref</sub> fin (MHz)	N	INPUT CODE PIN NO.									
		RX (AM) ±1.5 kHz	TX (LSB) RX (LSB) ± 1.5 kHz	TX (AM USB) RX (USB) ± 1.5 kHz			9	10	11	12	13	14	15	16		
1	26.965	34.765	19.1625	34.7675	1.28	128	1	0	0	0	0	0	0	0	0	0
2	26.975	34.775	19.1725	34.7775	1.29	129	1	0	0	0	0	0	0	0	0	1
3	26.985	34.785	19.1825	34.7875	1.30	130	1	0	0	0	0	0	0	1	0	0
4	27.005	34.805	19.2025	34.8075	1.32	132	1	0	0	0	0	0	1	0	0	0
5	27.015	34.815	19.2125	34.8175	1.33	133	1	0	0	0	0	0	1	0	1	1
6	27.025	34.825	19.2225	34.8275	1.34	134	1	0	0	0	0	0	1	1	1	0
7	27.035	34.835	19.2325	34.8375	1.35	135	1	0	0	0	0	0	1	1	1	1
8	27.055	34.855	19.2525	34.8575	1.37	137	1	0	0	0	0	1	0	0	0	1
9	27.065	34.865	19.2625	34.8675	1.38	138	1	0	0	0	0	1	0	1	1	0
10	27.075	34.875	19.2725	34.8775	1.39	139	1	0	0	0	0	1	0	1	1	1
11	27.085	34.885	19.2825	34.8875	1.40	140	1	0	0	0	0	1	1	0	0	1
12	27.105	34.905	19.3025	34.9075	1.42	142	1	0	0	0	0	1	1	1	1	0
13	27.115	34.915	19.3125	34.9175	1.43	143	1	0	0	0	0	1	1	1	1	1
14	27.125	34.925	19.3225	34.9275	1.44	144	1	0	0	1	0	0	0	0	0	0
15	27.135	34.935	19.3325	34.9375	1.45	145	1	0	0	1	0	0	0	0	0	1
16	27.155	34.955	19.3525	34.9575	1.47	147	1	0	0	1	0	0	0	1	1	1
17	27.165	34.965	19.3625	34.9675	1.48	148	1	0	0	1	0	1	0	0	0	0
18	27.175	34.975	19.3725	34.9775	1.49	149	1	0	0	1	0	1	0	1	0	1
19	27.185	34.985	19.3825	34.9875	1.50	150	1	0	0	1	0	1	1	1	1	0
20	27.205	35.005	19.4025	35.0075	1.52	152	1	0	0	1	1	1	0	0	0	0
21	27.215	35.015	19.4135	35.0175	1.53	153	1	0	0	1	1	1	0	0	0	1
22	27.225	35.025	19.4225	35.0275	1.54	154	1	0	0	1	1	1	0	1	0	0
23	27.255	35.055	19.4525	35.0575	1.57	157	1	0	0	1	1	1	1	0	1	1
24	27.235	35.035	19.4325	35.0375	1.55	155	1	0	0	1	1	1	0	1	1	1
25	27.245	35.045	19.4425	35.0475	1.56	156	1	0	0	1	1	1	1	0	0	0
26	27.265	35.065	19.4625	35.0675	1.58	158	1	0	0	1	1	1	1	1	1	0
27	27.275	35.075	19.4725	35.0775	1.59	159	1	0	0	1	1	1	1	1	1	1
28	27.285	35.085	19.4825	35.0875	1.60	160	1	0	1	0	0	0	0	0	0	0
29	27.295	35.095	19.4925	35.0975	1.61	161	1	0	1	0	0	0	0	0	0	1
30	27.305	35.105	19.5025	35.1075	1.62	162	1	0	1	0	0	0	0	1	0	0
31	27.315	35.115	19.5125	35.1175	1.63	163	1	0	1	0	0	0	0	1	1	1
32	27.325	35.125	19.5225	35.1275	1.64	164	1	0	1	0	0	0	1	0	0	0
33	27.335	35.135	19.5325	35.1375	1.65	165	1	0	1	0	0	0	1	0	1	1
34	27.345	35.145	19.5425	35.1475	1.66	166	1	0	1	0	0	0	1	1	0	0
35	27.355	35.155	19.5525	35.1575	1.67	167	1	0	1	0	0	0	1	1	1	1
36	27.365	35.165	19.5625	19.1675	1.68	168	1	0	1	0	1	0	0	0	0	0
37	27.375	35.175	19.5725	35.1775	1.69	169	1	0	1	0	1	0	0	0	1	1
38	27.385	35.185	19.5825	35.1875	1.70	170	1	0	1	0	1	0	1	0	1	0
39	27.395	35.195	19.5925	35.1975	1.71	171	1	0	1	0	1	0	1	0	1	1
40	27.405	35.205	19.6025	35.2075	1.72	172	1	0	1	0	1	1	1	0	0	0

# TRANSMITTER SECTION ALIGNMENT CHART

STEP	CONTROL SETTING	TEST EQUIPMENT	TEST EQUIPMENT SETTING	ADJUST	REFER TO
1 BPF	MODE – AM CH-19	Sweep Generator	Freq. : 27 MHz	T201 – 204 for max. out- put best wave form	Fig. 2
2	MODE – AM CH-19	RF Power Meter 50Ω dummy load DC current meter	Connect in series at TP-216	VR202 for 15 mA on the DC current meter	
3 AM POWER	MODE – AM CH-19	RF-Power Meter 50Ω dummy load		T205 – 208, L207, 208 for max. output	Fig. 3
4 AM POWER	MODE – AM CH-19	RF Power Meter 50Ω dummy load		VR-210 for 3.8 W output	Fig. 3
5 BM	MODE – LSB or USB CH-19	RF Power Meter 50Ω dummy load AF Generator Monitor Scope	AF Generator Freq. : 1 kHz Set the AF Generator out- put to get approx. 10 W.	VR-3, TC-7, T9 for min. carrier	Fig. 4
6 SSB MOD	MODE – LSB or USB CH-19	RF Power Meter 50Ω dummy load AF Generators Monitor Scope	2 AF Generators Freq. : 500/2400 Hz Output : approx. 30 mV	Set VR-204 to 0 ohm. (fully counterclockwise) VR-4 for 11 W PEP output	Fig. 5
7 AM AMC	MODE – AM CH-19	RF Power Meter 50Ω dummy load AF Generator Monitor Scope	AF Generator Freq. : 1 kHz Set the output to 50% Mod. + 16 dB	VR-5 for clean wave form with no over modu- lation ( should be 85~ 90% mod).	Fig. 3
8 ALC	MODE – LSB, USB or AM RECEIVE	DC VTVM	Connect DC VTVM to TP-208 (use TP-209 for ground connec- tion)	VR-207 for 1.2~1.8V	
9 ALC	MODE – LSB or USB CH-19	RF Power Meter 50Ω dummy load AF Generator Monitor Scope	AF Generator Freq. : 1 kHz Output: 15 mV + 6 db	VR-204 for 11 W PEP	Fig. 5
10 TWO TONE	MODE – LSB or USB CH-19	RF Power Meter 50Ω dummy load AF Generators Monitor Scope	2 AF Generators Freq. : 500/2400 Hz Output: Approx. 30 mV	VR-201 for clean wave form	Fig. 5

**NOTE :** You can check 7.8025 MHz in AM transmit mode at TP-204.

STEP	CONTROL SETTING	TEST EQUIPMENT	TEST EQUIPMENT SETTING	ADJUST	REFER TO
11 RF METER	MODE – AM CH-19	RF Power Meter 50Ω dummy load		VR-203 for same reading on built-in meter as power meter indication	Fig. 3
12 MOD IND	MODE – AM CH-19	RF Power Meter 50Ω dummy load AF Generator Monitor Scope	AF Generator Freq. : 1 kHz Set the AF Generator out- put to get 30% mod.	VR-208 for modulation lamp just comes on	Fig. 3
13 HAR- MONICS	MODE – AM CH-19	RF Power Meter 50Ω dummy load 54 MHz Monitor Receiver (or Spectrum Ana- lyzer if available)		TC-201 for min. reading on the receiver	Fig. 3

## RECEIVER SECTION ALIGNMENT CHART

STEP	CONTROL SETTING	TEST EQUIPMENT	TEST EQUIPMENT SETTING	ADJUST	REFER TO
1	SQ Minimum MODE – LSB or USB	Sweep Generator Oscilloscope	Frequency: 7.8 MHz	T209 for max. output and best wave form	Fig. 2
2 RF	SQ Minimum MODE – AM CH-19	RF Signal Generator Oscilloscope AC VTVM 8 Ω load	Frequency : 27.185 MHz MOD 30% at 1 kHz	T210, T211, T212 for max. output	Fig. 6
3 S-Meter	MODE – AM RF GAIN Maximum	RF Signal Generator	No signal	VR-206 for zero on the S-meter	Fig. 6
4 S-Meter	MODE – AM RF GAIN Maximum	RF Signal Generator	Output : 100 μV	VR-205 for S9 on the S-meter	Fig. 6
5 SQ	SQ Maximum MODE – AM	RF Signal Generator Oscilloscope AC VTVM 8 Ω Load	Channel 19 Output : 1 mV MOD. : 30% at 1 kHz	VR-209 to the point where wave form just shows	Fig. 6

# ALIGNMENT CONNECTIONS

## BAND PASS FILTER ALIGNMENT

Connect the instruments as shown in Figure 2.

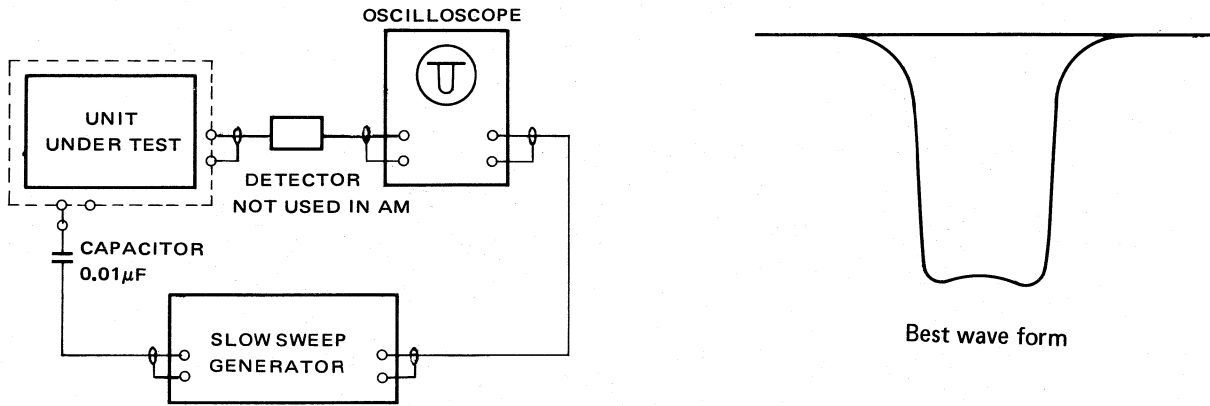

FIGURE 2

Mode Switch	Input Test Point		Output Test Point		Sweep Generator
	hot	ground	hot	ground	
AM	TP-201	TP-202	TP-205	TP-203	27 MHz
USB or LSB	TP-206 or TP-214	TP-207 or TP-215	TP-212	TP-213	7.8 MHz

## TRANSMITTING SECTION ALIGNMENT

Connect the instruments as shown in Figure 3.

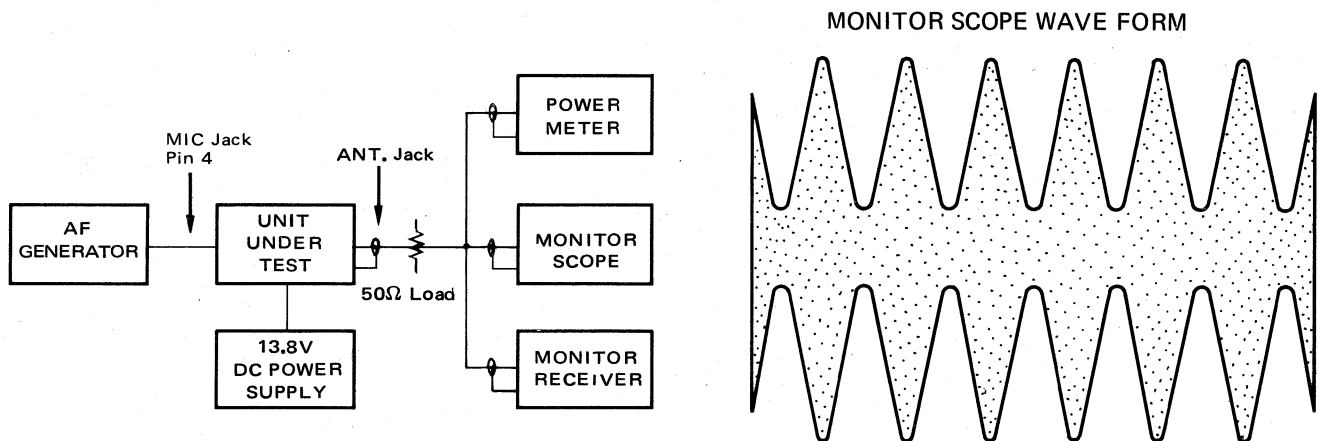

FIGURE 3

## BALANCED MODULATOR ALIGNMENT

Connect the instruments as shown in Figure 4.

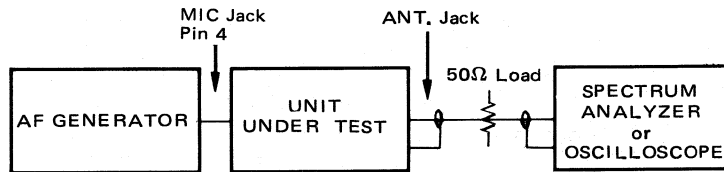
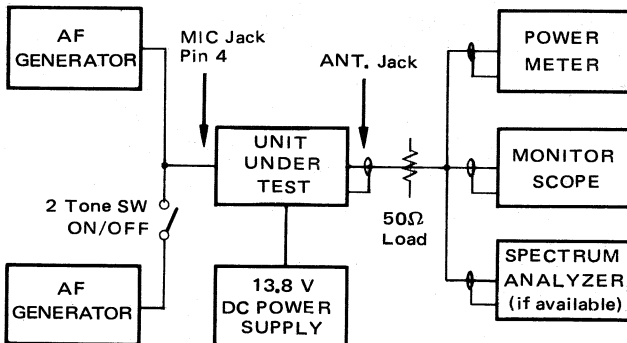

FIGURE 4

Step	Control Setting	Adjust	Remarks
1	SSB TX	AF Generator	To get 10W output power Note the carrier level at 10W output power
2	SSB TX	VR-3 T-9	Remove AF Generator Minimum carrier level
3	SSB TX	TC-7	Minimum carrier level
4	SSB TX		Repeat steps 2 and 3

## TRANSMITTING SECTION ALIGNMENT (SSB)

Connect the instrument as shown is Figure 5.



\* AF input frequency  
2500 Hz

\* AF Two-tone input frequency  
Select frequencies not related harmonically.  
The test tones of 500 Hz and 2400 Hz are suggested.

\* Idling current of Final Transistor : Approx. 50 mA

FIGURE 5

## RECEIVER SECTION ALIGNMENT

Connect the instruments as shown in Figure 6.

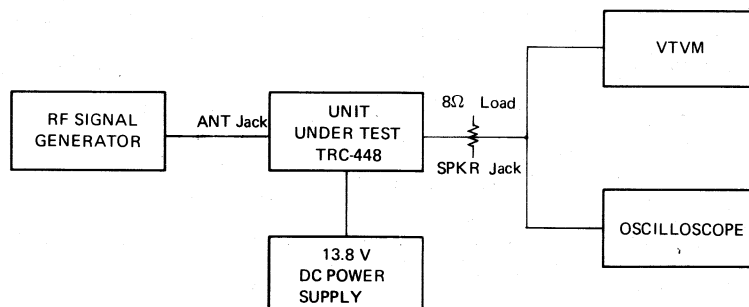
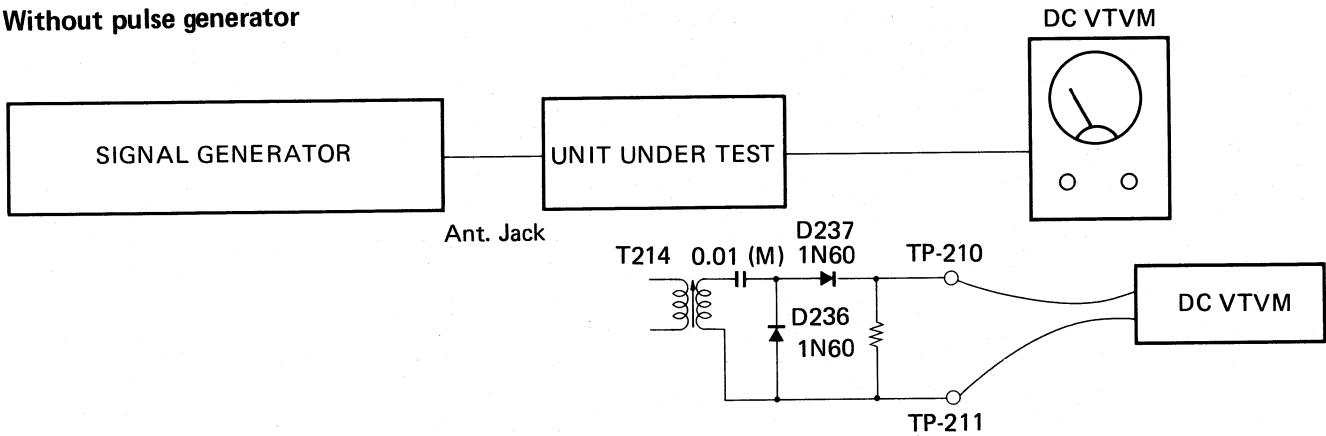

FIGURE 6

# NOISE BLANKER ALIGNMENT CHART

## Without pulse generator



Control Setting	Test Equipment	Adjust	Procedure
Channel -19	Signal Generator 40MHz (Output : 10 $\mu$ V)	T213 T214	Tune T213 and T214 for maximum reading on the DC VTVM
	Connect Oscilloscope		

## With pulse generator

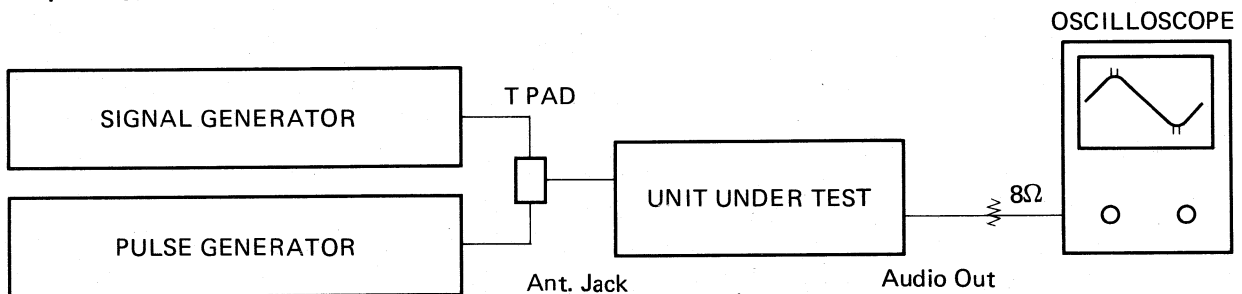

Control Setting	Test Equipment	Adjust	Procedure
CH : 19 (27.185 MHz)	Signal Generator (Output : 1 $\mu$ V)	T214	Tune T214 for Max. S/N ratio on the oscilloscope
	Pulse Generator (Pulse width : 1 $\mu$ Sec.) (Cycle : 10 mSec.) (Output : 1V P.P.)		
	Connect Oscilloscope		



# PLL P.C.BOARD (BOTTOM VIEW)

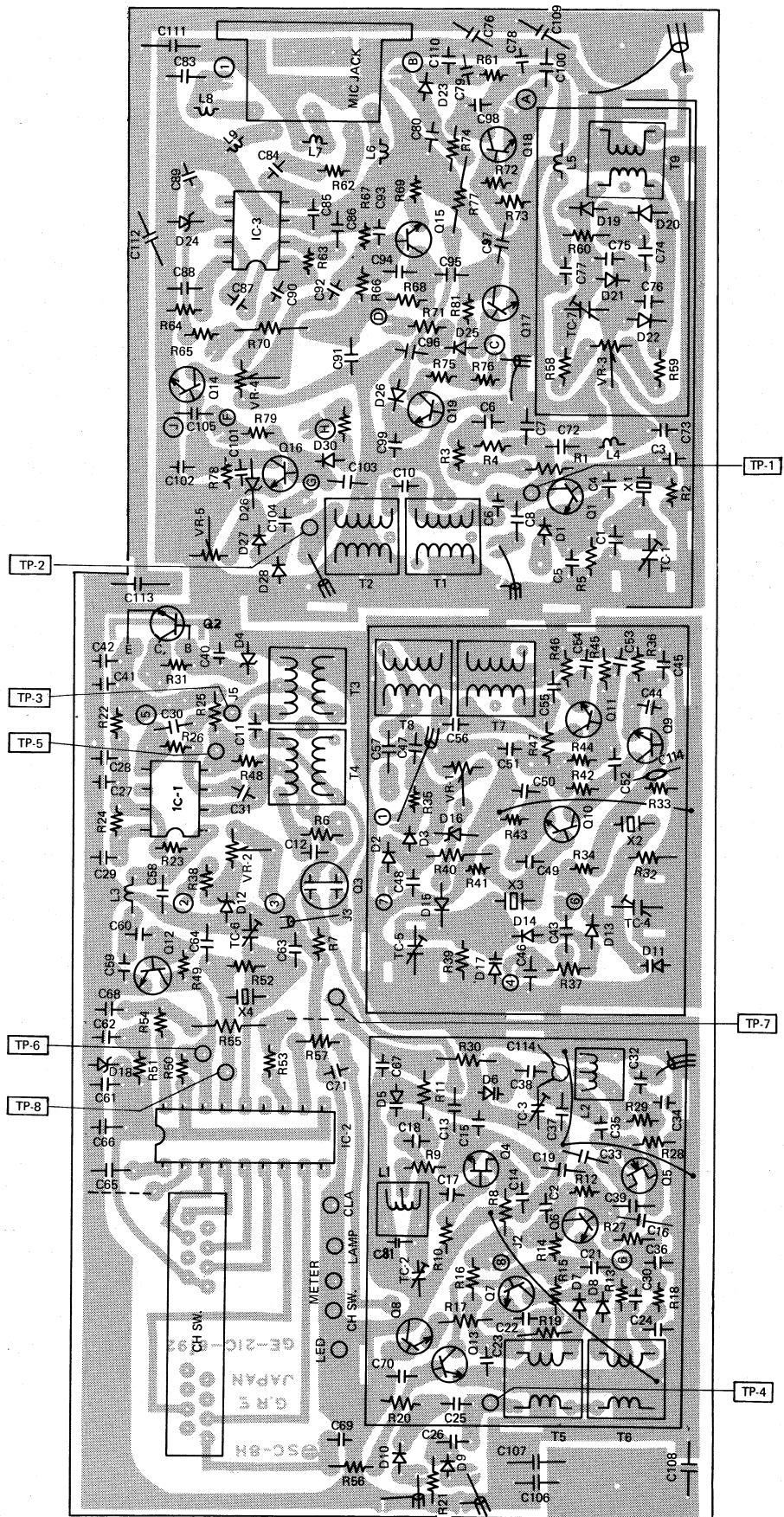

# MAIN P.C.BOARD (TOP VIEW)

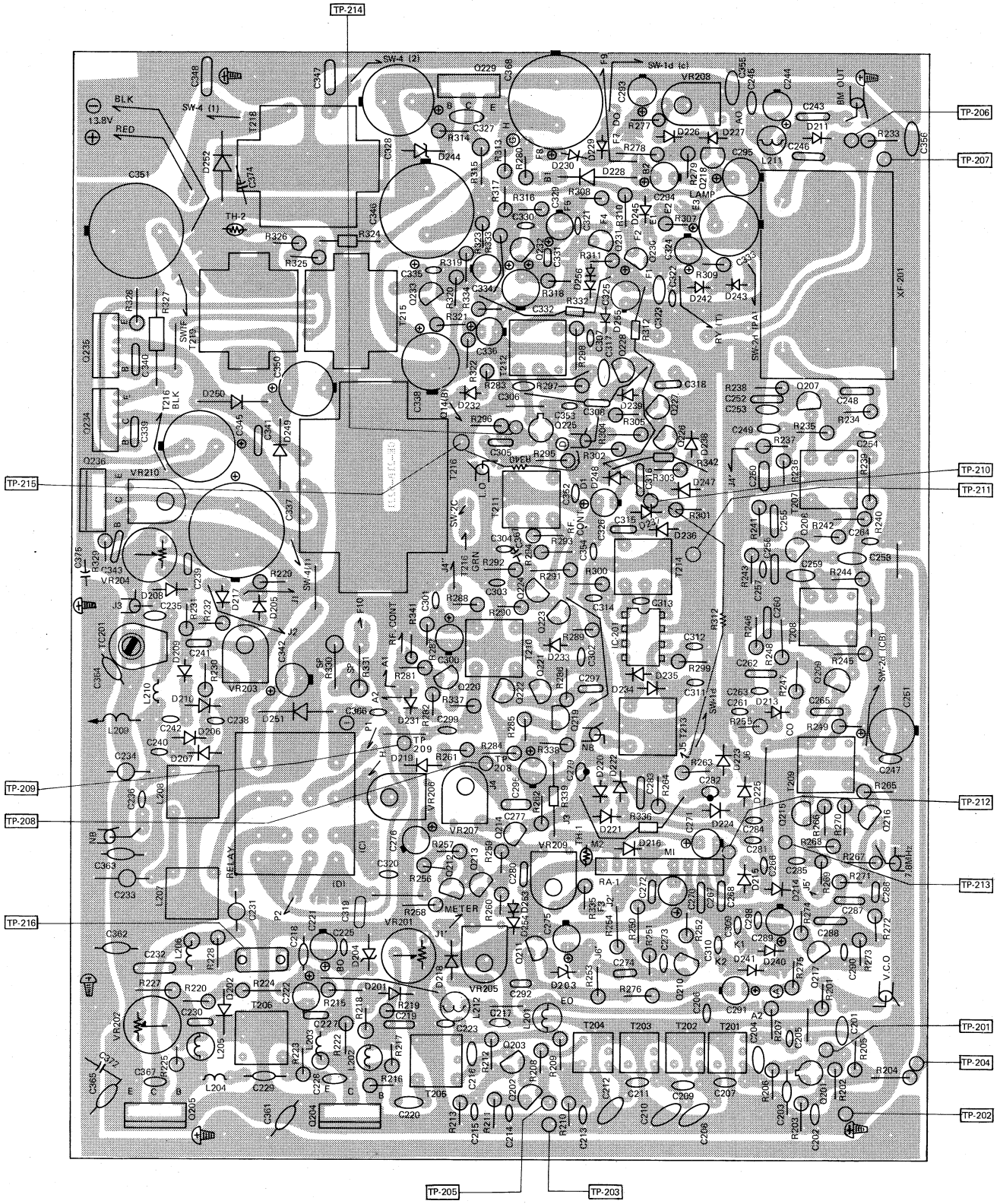



# WIRING DIAGRAM (1)

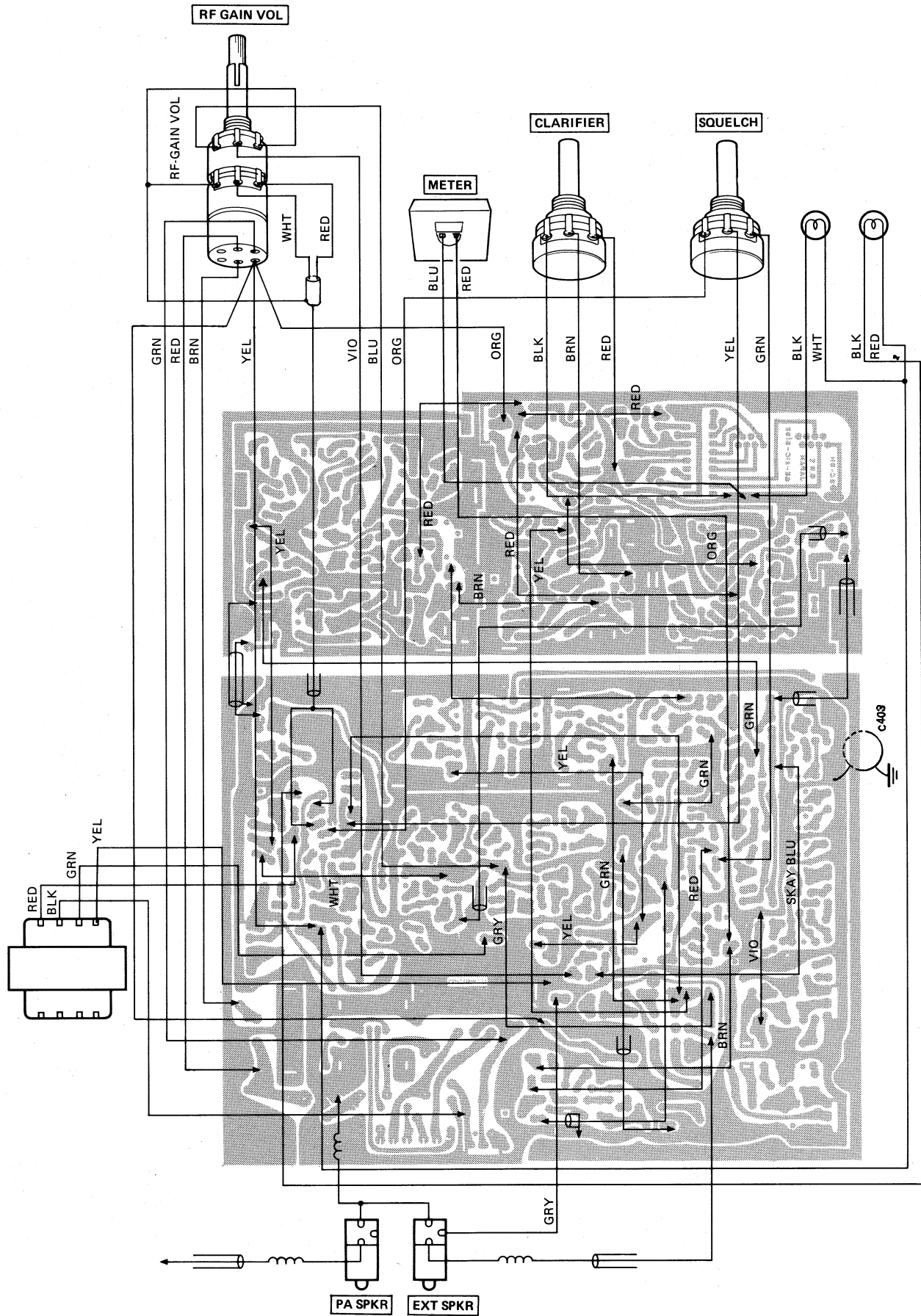

# WIRING DIAGRAM (2)

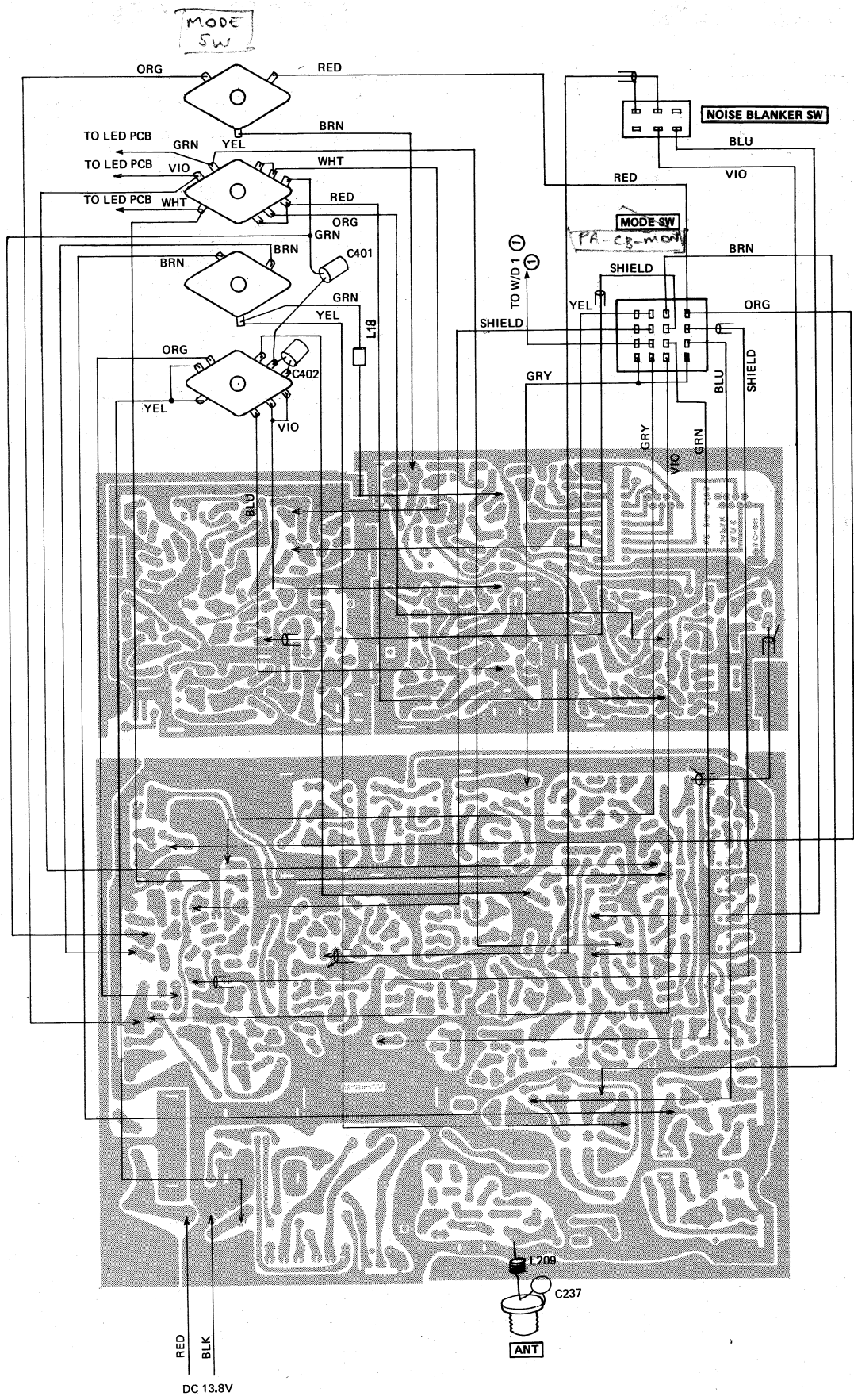

# LED P.C.BOARD

(TOP VIEW)

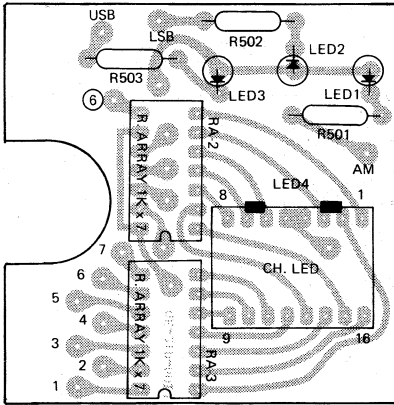

(BOTTOM VIEW)

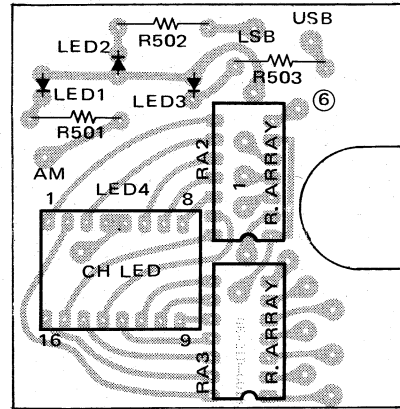

# LED P.C.BOARD/ CHANNEL SWITCH P.C.BOARD WIRING DIAGRAM

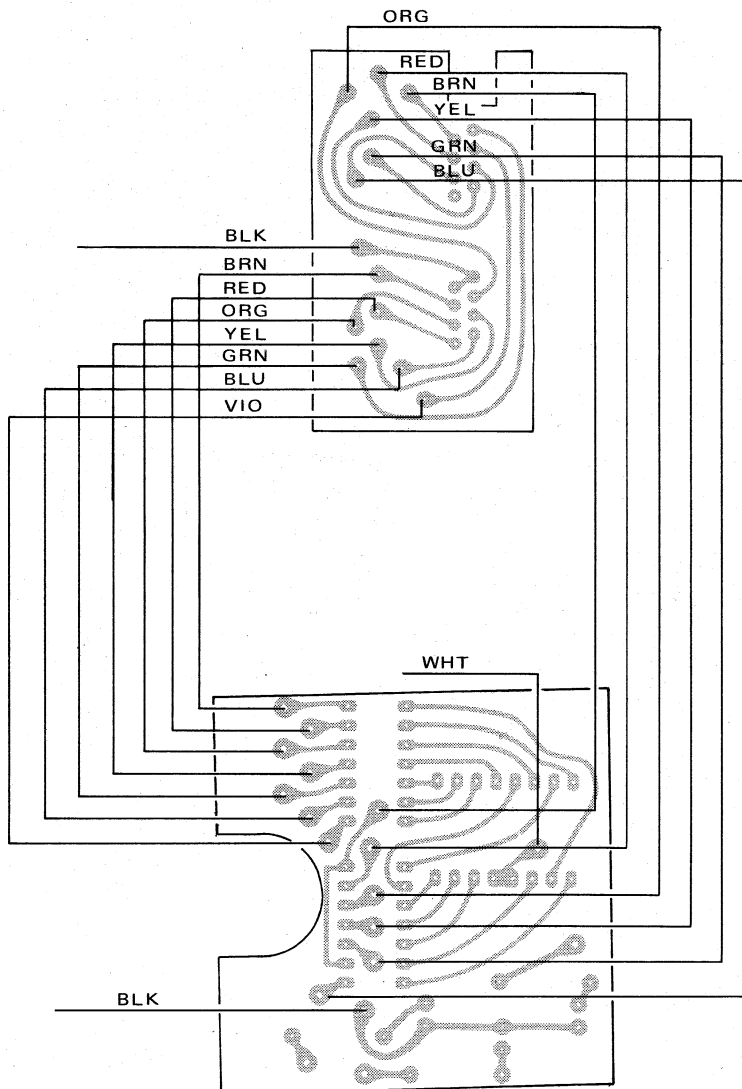

# TROUBLE SHOOTING

Before starting trouble shooting, first check the PLL section with the channel selector set at CH-19.

STEP	CONTROL SETTING	TEST POINT	TEST EQUIPMENT	OUTPUT	REMARKS
1	RX (AM)	TP-4	Freq. Counter	34.985 MHz	VCO freq.
2	RX (LSB) or TX (LSB)	TP-4	Freq. Counter	19.3825 MHz	VCO freq.

If above 2 steps are OK, the PLL section is OK.

## PLL SECTION

Symptom	Possible Cause
1) Wrong frequency in step 1 above	Defective Q5, D6, L2, Q9, X2, Q11, IC-1 and/or associated circuit components
2) Wrong frequency in step 2 above	Defective Q4, D5, L1, Q1, T1, T2, Q10, X3, Q11 and/or associated circuit components
3) Wrong frequency in both steps 1 and 2 above	Defective IC-2, X4, Q3, Q4, Q6, Q7, Q8, Q13 and/or channel selector switch

## OTHER SECTIONS

Symptom	Possible Cause
1) Meter lamp does not light and/or set fails to operate when power is on	A) Faulty DC power cord B) Defective Q229 and/or associated circuit components C) Defective power cord D) Defective meter lamp E) Fuse blown
2) Fuse blows	A) Collector of the Q204, Q205, Q234 and/or Q235 are shorted to chassis. B) Reverse polarity C) Defective Q204, Q205, Q234, Q235 and/or D204 D) Defective Q299 and/or D244
3) Does not receive AM RX SSB : OK TX AM SSB : OK	A) Defective D214, D215 and/or associated circuit components B) Defective Q210 and/or associated circuit components C) Defective Q211, D255 and/or associated circuit components

Symptom	Possible Cause
4) Does not receive SSB RX AM : OK TX AM SSB : OK	A) Defective Q215, Q216 and/or associated circuit components B) Defective Q217 and/or associated circuit components
5) Does not receive or transmit SSB RX AM : OK TX AM : OK	A) Defective Q1 and/or associated circuit components
6) Does not receive AM/SSB or transmit SSB TX AM : OK	A) Defective XF201, Q207, Q208, T207, T208 and/or associated circuit components
7) Does not receive both AM and SSB	A) Defective Q223, Q224, Q235 and/or associated circuit components
8) No sound TX AM SSB : OK	A) Defective speaker or defective EXT. SPKR jack B) Faulty Squelch control circuit C) Defective Relay
9) Does not transmit AM and SSB	A) Defective Q201, Q202, Q203, Q204, Q205 and/or associated circuit components B) Defective Relay, D251 and/or Microphone PTT switch C) Defective MODE Switch
10) Does not transmit AM TX SSB : OK	A) Defective Q236, D228, MODE switch and/or associated circuit components
11) Does not transmit SSB TX AM : OK RX AM SSB : OK	A) Defective IC-3, Q15, Q17, Q18 and/or associated circuit components B) Defective D19, D20, D21, D22, T9, D211 and/or associated circuit components C) Defective D249, D250 and/or associated circuit components
12) SQUELCH Control does not function	A) Defective VR-209 and/or VR-303 B) Defective VR-206 C) Defective Q230, Q231 and/or associated circuit components
13) Receiver oscillates on AM RX SSB : OK	A) Defective D1 B) Defective MODE switch
14) Low sensitivity TX SSB : OK	A) Faulty AGC circuit Q219, Q220, Q221 and/or associated circuit components B) Defective Q228 and/or associated circuit components C) Defective Q223, Q224, Q225 and/or associated circuit components
15) No modulation on AM TX SSB : OK RX AM : OK	A) Defective IC-3, Q15, Q17, Q18 and/or associated circuit components B) Defective T216

Symptom	Possible Cause
16) Modulation indicator does not flash on AM. MOD : OK	A) Defective Q218, D226, D227 and/or associated circuit components B) Defective modulation indicator lamp
17) Meter lamp does not turn on in RX.	A) Defective D229
18) Meter lamp does not turn on in MON/PA	A) Defective D230
19) RX AGC and SSB TX ALC does not work	A) Defective Q214 and/or associated circuit components
20) Noise blanker and ANL does not work.	A) Defective IC-201, Q226, Q228, D236, D237, D238, D239 and/or associated circuit components B) Defective D216 and/or associated circuit components C) Defective NB switch
21) PA does not work. CB : OK	A) Defective PA—CB switch B) Defective PA jack
22) RF control does not work.	A) Defective Q220, D253 and/or associated circuit components
23) CLARIFIER does not work.	A) Defective D12, D13, D14 and/or associated circuit components B) Defective VR-304 and/or VR-2

**REVISION  
FOR  
AUSTRALIAN MODEL OF TRC-448  
Catalog Number : 21-9448**

When servicing Australian model of TRC-448 (Catalog Number 21-9448), refer to the Service Manual for TRC-448 (Catalog Number 21-1561) as well as the following revision:

Page 4

**SPECIFICATION**

**GENERAL**

Frequency Range: 26.965 to 27.405 should be **27.015 to 27.225 MHz.**

Channel: 40 channels should be **18 channels.**

Page 6

**PRINCIPLES OF OPERATION**

**PLL CIRCUIT**

3rd paragraph

2nd line: Q5 VCO frequency (34.7675 to 35.2075 MHz) should read **34.8175 to 35.0275 MHz.**

3rd line: down-mix produces signals of 1.28 through 1.72 MHz should read **1.33 through 1.54 MHz.**

4th line: "N" (128 through 172) should read **N (133 through 154).**

7th paragraph

2nd line: Q5 VCO frequency (34.765 to 35.205) should read **34.815 to 35.025.**

3rd line: down-mix produces 1.28 through 1.72 should read **1.33 through 1.54 MHz.**

4th and 5th line: deriving the required 1.28 through 1.72 MHz should read **1.33 through 1.54 MHz.**

8th paragraph

3rd and 4th line: Q4 VCO frequency (19.1625 to 19.6025 MHz) should read **19.2125 to 19.4225 MHz.**

4th line: up-mix produces 34.7675 through 35.2075 MHz should read **34.8175 through 35.0275 MHz.**

6th line: The 1.28 through 1.72 MHz should read **1.33 through 1.54 MHz.**

7th line: deriving the required 1.28 through 1.72 MHz should read **1.33 through 1.54 MHz.**

### PLL CIRCUIT BLOCK DIAGRAM

#### AM and USB

Q5 VCO frequency 34.765 ~ 35.2075 should be 34.815 ~ 35.025 MHz.  
IC-1 MIXER output frequency 1.28 ~ 1.72 should be 1.33 ~ 1.54 MHz.

#### LSB

Q4 VCO frequency 19.1625 ~ 19.6025 should be 19.2125 ~ 19.4225 MHz.  
Q3 MIXER output frequency 34.7675 ~ 35.2075 should be 34.8175 ~ 35.0275 MHz.  
IC-1 MIXER output frequency 1.28 ~ 1.72 MHz should be 1.33 ~ 1.54 MHz.

### PLL SECTION ALIGNMENT CHART

Control Setting: CH-19 should be CH-9.

Step 7 Adjust T3-3 for 2.7V DC  $\pm$  0.1V.

Step 8 Adjust T3, T4 34.9175 MHz.

Step 9 Adjust TC-2 for 2.7 V DC.

Step 10 Adjust T6 for max. output at 34.915 MHz.

Step 11 Adjust T5 for max. output at 19.3125 MHz.

NOTE 2 should read as follow; Step 7 and 9, DC output should change from 2.7 $\pm$ 0.1 volts on CH-1 to approx. 3.2 volts on CH-18.

### VCO OUTPUT FREQUENCY, IC-2 INPUT FREQUENCY AND CODE TABLE

Refer to the following table.

CH	FREQUENCY (MHz)	VCO (MHz)			N <sub>fin</sub> (MHz)	N	INPUT CODE PIN No.							
		RX (AM)	TX (LSB) RX (LSB)	TX (AM USB) RX (USB)			9	10	11	12	13	14	15	16
1	27.015	34.815	19.2125	34.8175	1.33	133	1	0	0	0	0	1	0	1
2	27.025	34.825	19.2225	34.8275	1.34	134	1	0	0	0	0	1	1	0
3	27.035	34.835	19.2325	34.8375	1.35	135	1	0	0	0	0	1	1	1
4	27.055	34.855	19.2525	34.8575	1.37	137	1	0	0	0	1	0	0	1
5	27.065	34.865	19.2625	34.8675	1.38	138	1	0	0	0	1	0	1	0
6	27.085	34.885	19.2825	34.8875	1.40	140	1	0	0	0	1	1	0	0
7	27.095	34.895	19.2925	34.8975	1.41	141	1	0	0	0	1	1	0	1
8	27.105	34.905	19.3025	34.9075	1.42	142	1	0	0	0	1	1	1	0
9	27.115	34.915	19.3125	34.9175	1.43	143	1	0	0	0	1	1	1	1
10	27.125	34.925	19.3225	34.9275	1.44	144	1	0	0	1	0	0	0	0
11	27.135	34.935	19.3325	34.9375	1.45	145	1	0	0	1	0	0	0	1
12	27.155	34.955	19.3525	34.9575	1.47	147	1	0	0	1	0	0	1	1
13	27.165	34.965	19.3625	34.9675	1.48	148	1	0	0	1	0	1	0	0
14	27.175	34.975	19.3725	34.9775	1.49	149	1	0	0	1	0	1	0	1
15	27.185	34.985	19.3825	34.9875	1.50	150	1	0	0	1	0	1	1	0
16	27.195	34.995	19.3925	34.9975	1.51	151	1	0	0	1	0	1	1	1
17	27.205	35.005	19.4025	35.0075	1.52	152	1	0	0	1	1	0	0	0
18	27.225	35.025	19.4225	35.0275	1.54	154	1	0	0	1	1	0	1	0

### TRANSMITTER SECTION ALIGNMENT CHART & RECEIVER SECTION ALIGNMENT CHART

Control Setting: CH19 should be CH9.

### NOISE BLANKER ALIGNMENT CHART

Control Setting: CH19 should be CH9 27.115 MHz.

### WIRING DIAGRAM

Cut a PLL P.C. Board pattern open at pin 11 of IC-2.

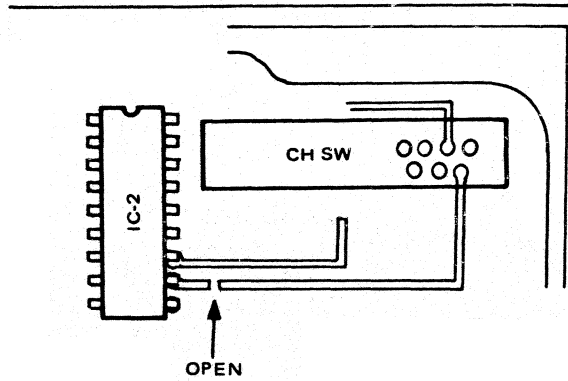

### LED P.C. BOARD/CHANNEL SWITCH P.C. BOARD WIRING

\* 2 BRN, 1 RED and 1 ORG wires are not necessary.

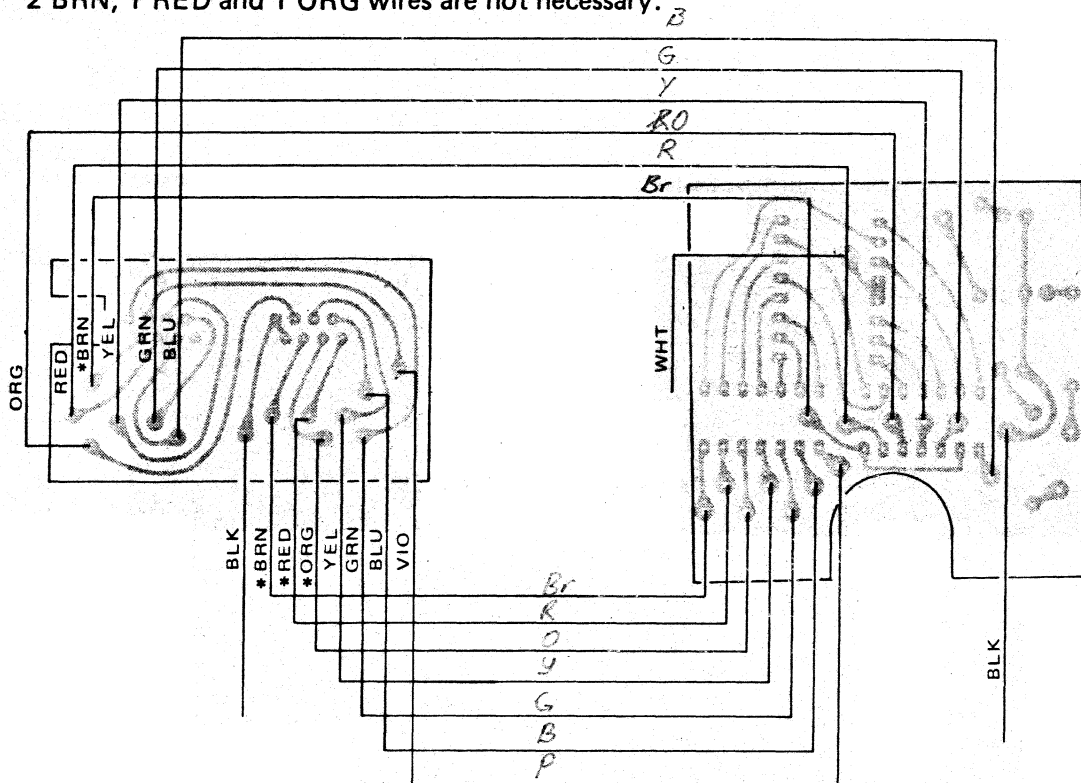

**TROUBLE SHOOTING**

Read first line as follow: Before starting trouble shooting first check the PLL section with the channel selector set at **CH-15**.

**CHASSIS ASSEMBLY PARTS LIST**

(7) Channel SW. MFR's Part Number should be **SRH202J**.

**TANDY CORPORATION**

**280-316 VICTORIA ROAD  
RYDALMERE. N.S.W., 2116  
AUSTRALIA**

# EXPLODED VIEW

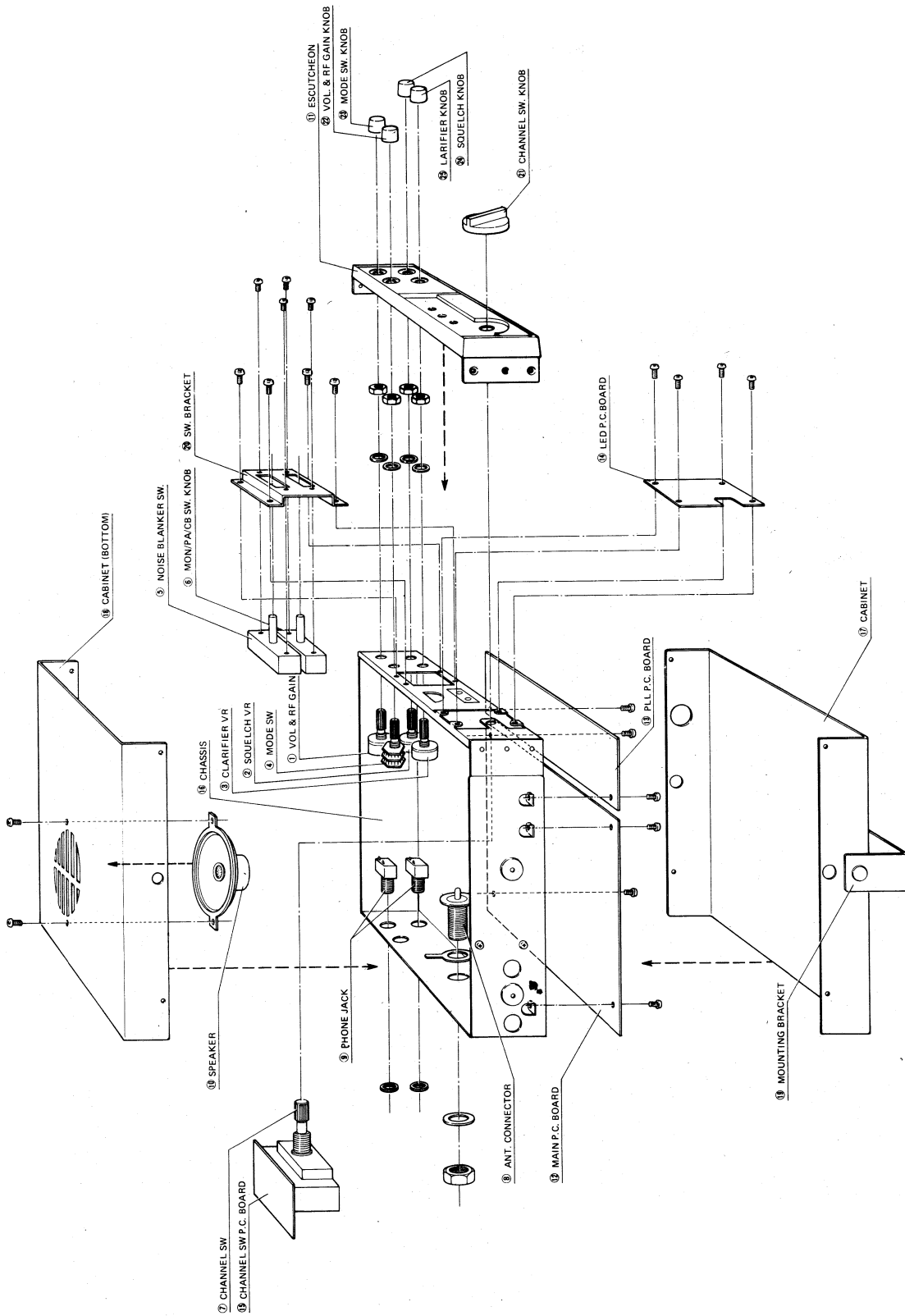

# SCHEMATIC DIAGRAM

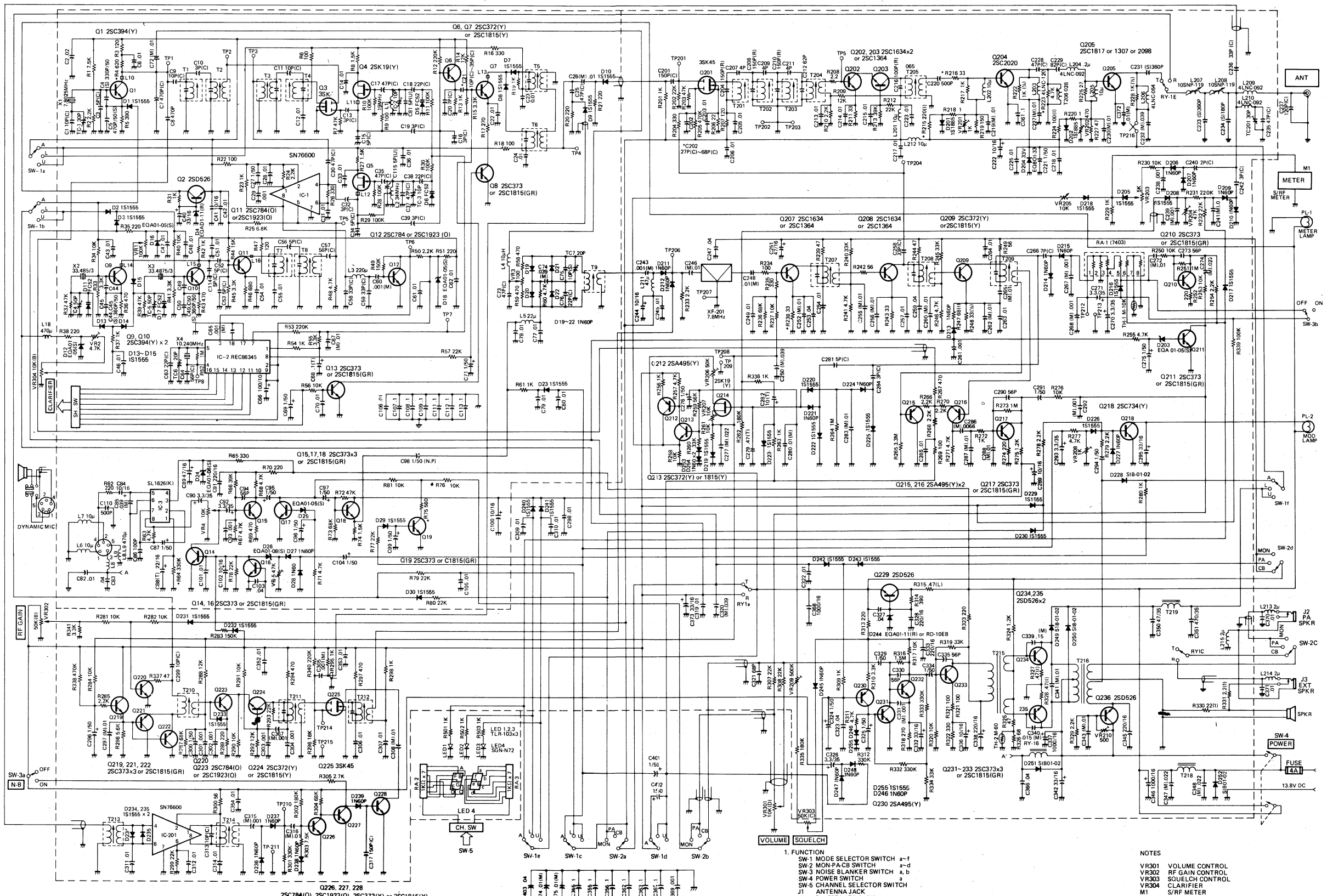

1. FUNCTION  
 SW-1 MODE SELECTOR SWITCH a-f  
 SW-2 MON-P.A.C.B SWITCH a-d  
 SW-3 NOISE BLANKER SWITCH a-b  
 SW-4 POWER SWITCH a-b  
 SW-5 CHANNEL SELECTOR SWITCH  
 J1 ANTENNA JACK  
 J2 P.A. SPEAKER JACK  
 J3 EXTERNAL SPEAKER JACK  
 J4 MICROPHONE JACK
2. RESISTANCE VALUES IN OHMS (K=1000, M=1000K)
3. CAPACITANCE VALUES IN  $\mu$ F (P=PF)
4. RATING OR TYPE NUMBER OF COMPONENT PARTS ARE SUBJECT TO CHANGE FOR IMPROVEMENT WITHOUT NOTICE
5. \* NOT ALWAYS USED

- NOTES
- VR301 VOLUME CONTROL
  - VR302 RF GAIN CONTROL
  - VR303 SQUELCH CONTROL
  - VR304 CLARIFIER
  - M1 S/R/F METER
  - PL-1 METER INDICATOR
  - PL-2 MOD./TRANSMIT INDICATOR
  - LED 1 AM SECTION INDICATOR
  - LED 2 USB SECTION INDICATOR
  - LED 3 USB SECTION INDICATOR
  - LED 4 CHANNEL INDICATOR

# SEMICONDUCTORS LEAD IDENTIFICATION

(A) : 2SA495(O), 2SC372(O), 2SC373, 2SC387(A), 2SC394(Y), 2SC784

(B) : 2SK19(Y)

(C) : 2SD526, 2SC2020, 2SC2098

(D) : 2SC1634, 2SC1364, 2SC1815, 2SC1923

(E) : 3SK45, 3SK35

(A) (B)

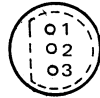
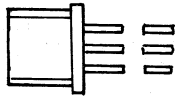

(A)

1. Base
2. Collector
3. Emitter

(B)

1. Gate
2. Source
3. Drain

(C)

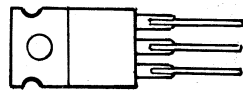

(C)

1. Emitter
2. Collector (Heat Sink)
3. Base

(D)

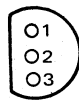
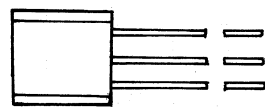

(D)

1. Base
2. Collector
3. Emitter

(E)

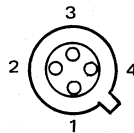
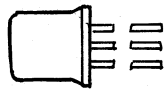

(E)

1. Drain
2. Gate 2
3. Gate 1
4. Source (Case)

## IC PIN CONFIGURATIONS

SN76600 SCHEMATIC DIAGRAM

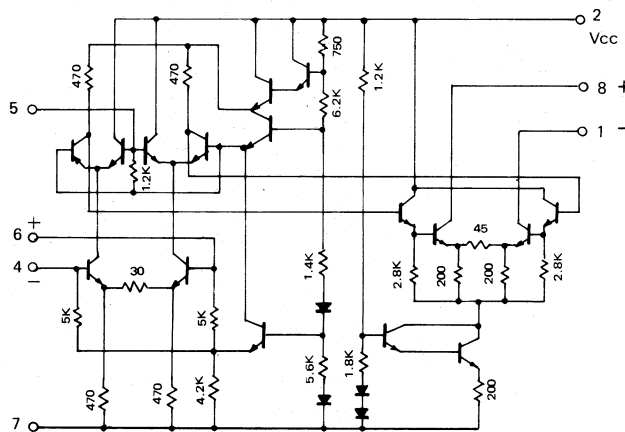

SN76600 LEAD IDENTIFICATION

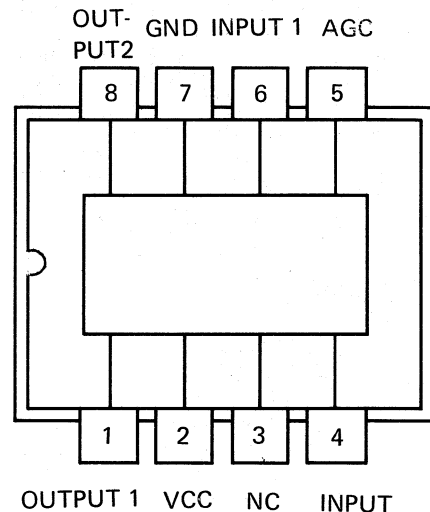



**RADIO SHACK**  **A DIVISION OF TANDY CORPORATION**  
**U.S.A.: FORT WORTH, TEXAS 76102**  
**CANADA: BARRIE, ONTARIO L4M 4W5**

---

**TANDY CORPORATION**

<b>AUSTRALIA</b>	<b>BELGIUM</b>	<b>U. K.</b>
<b>280-316 VICTORIA ROAD RYDALMERE. N.S.W. 2116</b>	<b>PARC INDUSTRIEL DE NANINNE 5140 NANINNE</b>	<b>BILSTON ROAD WEDNESBURY, WEST MIDLANS WS10 7JN</b>