

# AM/SSB CB Transceiver

TRC-458-18



## OWNER'S MANUAL

PLEASE READ BEFORE  
USING THIS EQUIPMENT

**REALISTIC**<sup>®</sup>

CAT. NO.  
21-9458

CUSTOM MANUFACTURED FOR TANDY CORPORATION

Your **REALISTIC TRC-458-18** is a completely solid-state AM/SSB Transceiver for 27 MHz Citizens Band use. It uses a frequency synthesizing circuit with Digital Phase Locked Loop techniques to provide crystal-controlled transmit and receive operation on all 18 channels. The PLL circuitry assures ultra-precise frequency control. You can use your TRC-458-18 Transceiver on any one of the 18 channels in the conventional AM mode, plus the same 18 channels in either the Upper Single Sideband mode or the Lower Single Sideband mode.

This flexibility not only doubles the effective number of channels from 18 to 54, but SSB also increases the effective range of communication because all the power is concentrated in one sideband to provide 100% talk-power. Single Sideband reception also adds advantages in sensitivity and selectivity, plus lower signal-to-noise. This of course also contributes to an increase in operating range.

The TRC-458-18 has been carefully designed for ease of operation. You can select AM, Upper Sideband or Lower Sideband with the simple change of a 3-position switch. Transmission is simple too—just press the microphone button. Ordinarily an SSB signal will reach farther and be heard more clearly than an equivalent AM signal. SSB reception is simple—just adjust the CLARIFIER control to bring in the voice transmissions.

We've added all the other most wanted features for optimum communications—RF Gain control, Squelch, Clarifier, PA, switchable Automatic Noise Limiter and Noise Blanker circuits, RF-S meter and Crystal Lattice Filter.

The TRC-458-18 is designed to operate from 12 volt DC **negative or positive ground electrical systems**, or from 240 Volt AC power.

For your own protection, we urge you to record the Serial Number of this unit in the space provided. You'll find the Serial Number on the back panel of the unit.

Serial Number
---------------

## SPECIFICATIONS

### GENERAL:

<b>Channels</b>	: 18 Channels for AM, Upper Side Band and Lower Side Band, utilizing Digital Circuitry
<b>Frequency Range</b>	: 27.015MHz to 27.225MHz
<b>Frequency Control</b>	: Digital (Phase Lock Loop) Synthesizer
<b>Frequency Accuracy</b>	: $\pm 100$ Hz
<b>Operating Temperature Range</b>	: $-20^{\circ}\text{C}$ to $+50^{\circ}\text{C}$
<b>Power Requirements</b>	: 13.8V DC (12-16 volts DC, negative or positive ground) or 240V AC
<b>Antenna</b>	: 52 ohm (Coaxial connector)
<b>Microphone</b>	: 600 ohm Dynamic Type
<b>Speaker</b>	: 8 ohm, 2.5 Watt
<b>Size</b>	: 4" (H) x 13-1/2" (W) x 11-1/2" (D) (10 x 34.3 x 29.2 cm)
<b>Weight</b>	: 14 Lbs. (approx.) (6.5 kg)
<b>Accessories</b>	: DC Cord with in-line Fuse, Microphone and Microphone Hanger and Mounting Brackets

## RECEIVER:

<b>Max Sensitivity</b>	: AM — 0.5 $\mu$ V SSB — 0.25 $\mu$ V
<b>Sensitivity for 10 dB S/N</b>	: AM — 0.5 $\mu$ V or better SSB — 0.25 $\mu$ V or better
<b>AGC Figure of Merit 50 mV for 10 dB Change in Audio output</b>	: AM — 80 dB SSB — 80 dB
<b>Overload AGC Characteristics from 10 mV to 100 mV</b>	: AM — $\pm$ 3 dB SSB — $\pm$ 3 dB
<b>Overall Audio Fidelity at 6 dB Down Adjacent Channel Selectivity</b>	: 300 — 2100 Hz : AM — 70 dB SSB — 70 dB
<b>Image Rejection (42.6 MHz)</b>	: 80 dB
<b>IF Rejection</b>	: 80 dB
<b>Maximum Audio Output Power</b>	: 4 Watts
<b>Squelch Range</b>	: AM — Adjustable from 0.5 $\mu$ V to 1 mV SSB — Adjustable from 0.25 $\mu$ V to 1 mV
<b>Receiver Clarifier Range</b>	: $\pm$ 1.25 kHz, variable
<b>Battery Drain at no Signal</b>	: 700 mA
<b>Battery Drain at Max. Output Power</b>	: 1,600 mA
<b>AC Power Drain</b>	: At no Signal — 40 Watts : At Max. Output Power — 60 Watts

## TRANSMITTER:

<b>Max. Output Power</b>	: AM — 4 Watts SSB — 12 Watts
<b>Spurious Emission</b>	: — 65 dB or better
<b>Modulation Frequency Response (1 kHz, 0 dB reference)</b>	
<b>Lower at 450 Hz, EIA</b>	: AM — -6 dB SSB — -6 dB
<b>Upper at 2.5 kHz, EIA</b>	: AM — -6 dB SSB — -6 dB
<b>Microphone Sensitivity</b>	
<b>AM : For 50% Mod.</b>	: AM — 0.4 mV
<b>SSB : For 4 Watts PEP</b>	: SSB — 0.4 mV
<b>Microphone Amplifier Circuit Dynamic Range</b>	: AM — 60 dB (between 98% and 80% modulation) : SSB — 60 dB (between 12W P.E.P. and 10W P.E.P.)
<b>Battery Drain</b>	: At no Modulation — AM/2,400 mA SSB/1,500 mA At Max. Output Power — AM/3,000 mA — SSB/2,700 mA
<b>AC Power Drain</b>	: At no Modulation — AM/65 Watts SSB/45 Watts At Max. Output Power — AM/100 Watts SSB/100 Watts

## PUBLIC ADDRESS AMPLIFIER:

<b>Maximum Output Power</b>	: 6 Watts
-----------------------------	-----------

**WARNING: To prevent fire or shock hazard, do not expose this Transceiver to rain or moisture.**

# C.R.S. LICENCE (AUSTRALIA)

Before transmitting with your transceiver, you must obtain a Postal and Telecommunications Department Citizens Radio Service licence. We have provided such an application form with your unit. Before completing the form you should read the conditions governing the licensing and operation of the Citizens Radio Service (P. and T. Dept. brochure RB14). This brochure can be obtained from the P. and T. Department. After completing the application form, mail it with the appropriate fee to the Superintendent, Regulatory and Licensing in the state or territory in which the station will be operated.

Postal and Telecommunications

Department Approval Number \_\_\_\_\_

## FREQUENCIES AVAILABLE FOR CITIZENS RADIO SERVICE OPERATION

Channel	MHz	Channel	MHz	Channel	MHz
1	27.015	7	27.095	13	27.165
2	27.025	8	27.105	14	27.175
3	27.035	9	27.115	15	27.185
4	27.055	10	27.125	16	27.195
5	27.065	11	27.135	17	27.205
6	27.085	12	27.155	18	27.225

Note: Channel 5 is used for Emergency call.

# INSTALLATION

**CAUTION:** Do not attempt to operate your Transceiver without an Antenna or dummy-load connected to the ANTENNA jack. To do so may damage your Transceiver.

For fixed or base station operation, simply connect the AC power plug of the Transceiver to a source of 240 volt 50 Hz AC power and set DC-AC switch on the back of the Transceiver to AC. The only other thing you require is an Antenna connection.

Safety and convenience are the primary considerations for mounting any piece of mobile equipment. All controls must be readily available to the operator without interfering with the movements necessary for safe operation of the vehicle. Be sure all cables are clear of the brake, clutch and accelerator. Also, thought must be given to the convenience of passengers (will they have adequate leg room?).

Another extremely important requirement is the ease of installation and removal (for service and maintenance). Mount the transceiver so it can be slipped in and out very easily.

The most common mounting position for a transceiver of this size is under the dashboard directly over the driveshaft hump. Do not mount the transceiver in the path of the heater or airconditioning air stream. Be sure the chassis of the transceiver is electrically connected to the ground system of the vehicle or boat. Use a separate ground wire to be sure.

When you have determined the best location for mounting, temporarily mount the brackets to the side of the unit. Use the unit, with brackets installed, as a template to mark where the holes are to be drilled. Take care when you drill holes that you do not drill into wiring, trim or other accessories. Remove the brackets from the unit and assemble them to the dash as shown in illustration. Mount the transceiver in position with bolts, lockwashers and nuts or selfthreading screws.

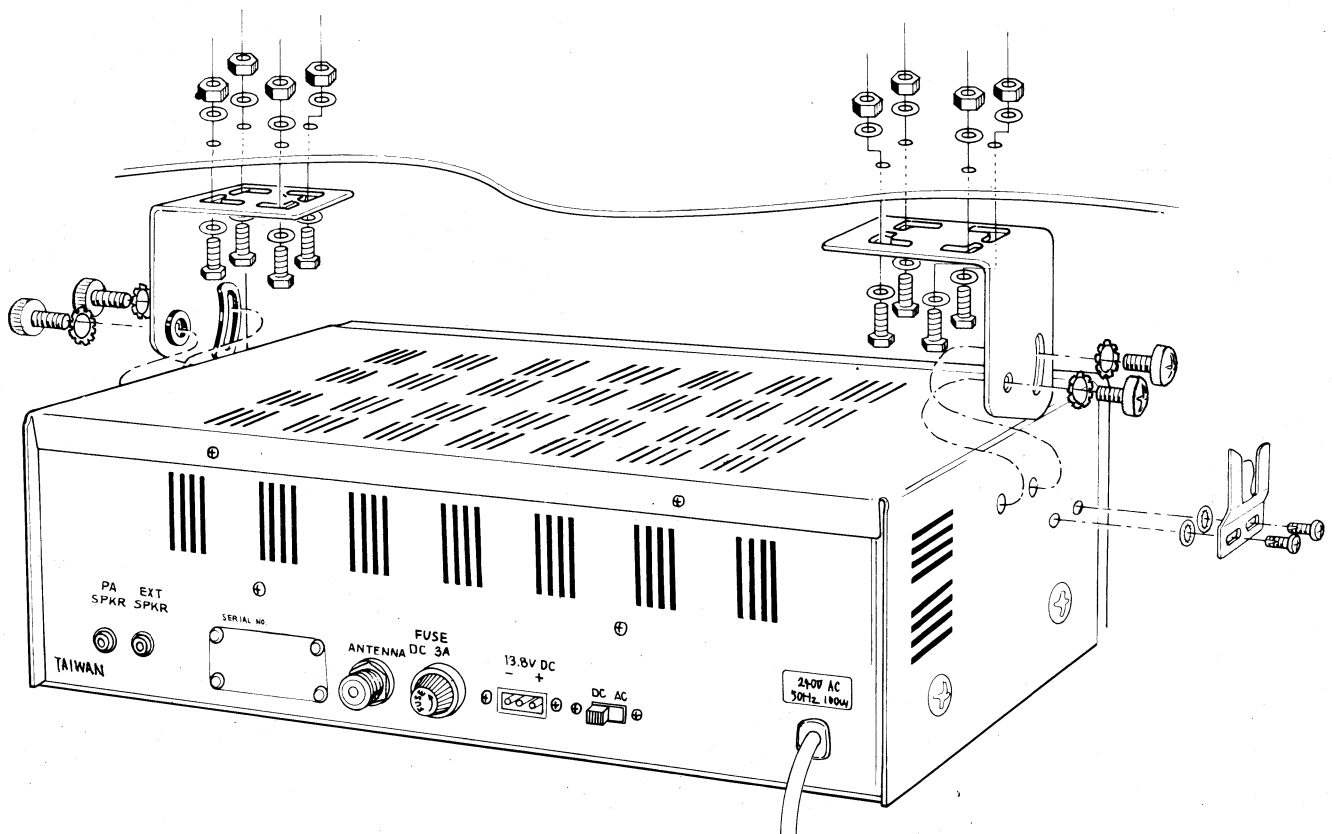

**For Negative Ground Electrical Systems:** Connect the Red wire (with in-line fuse holder) to the Accessory terminal on the ignition switch of your vehicle. Make a good mechanical and electrical connection to the frame of the vehicle for the black (negative) wire.

**For Positive Ground Electrical Systems:** Connect the Black wire to the Accessory switch "hot" terminal and connect the Red Wire to the metal frame of the vehicle. Thus, Black always goes to negative (-) and Red always goes to positive (+).

You can use an auto accessory plug (TANDY Catalog No. 274-331) to connect your transceiver to the vehicle's cigarette lighter socket. However, it is better to connect the DC power cord directly to the accessory terminal of the ignition switch. This will prevent unauthorized usage of the transceiver, and will also prevent you from leaving the transceiver on unintentionally.

Set DC-AC switch on the back panel to DC position.

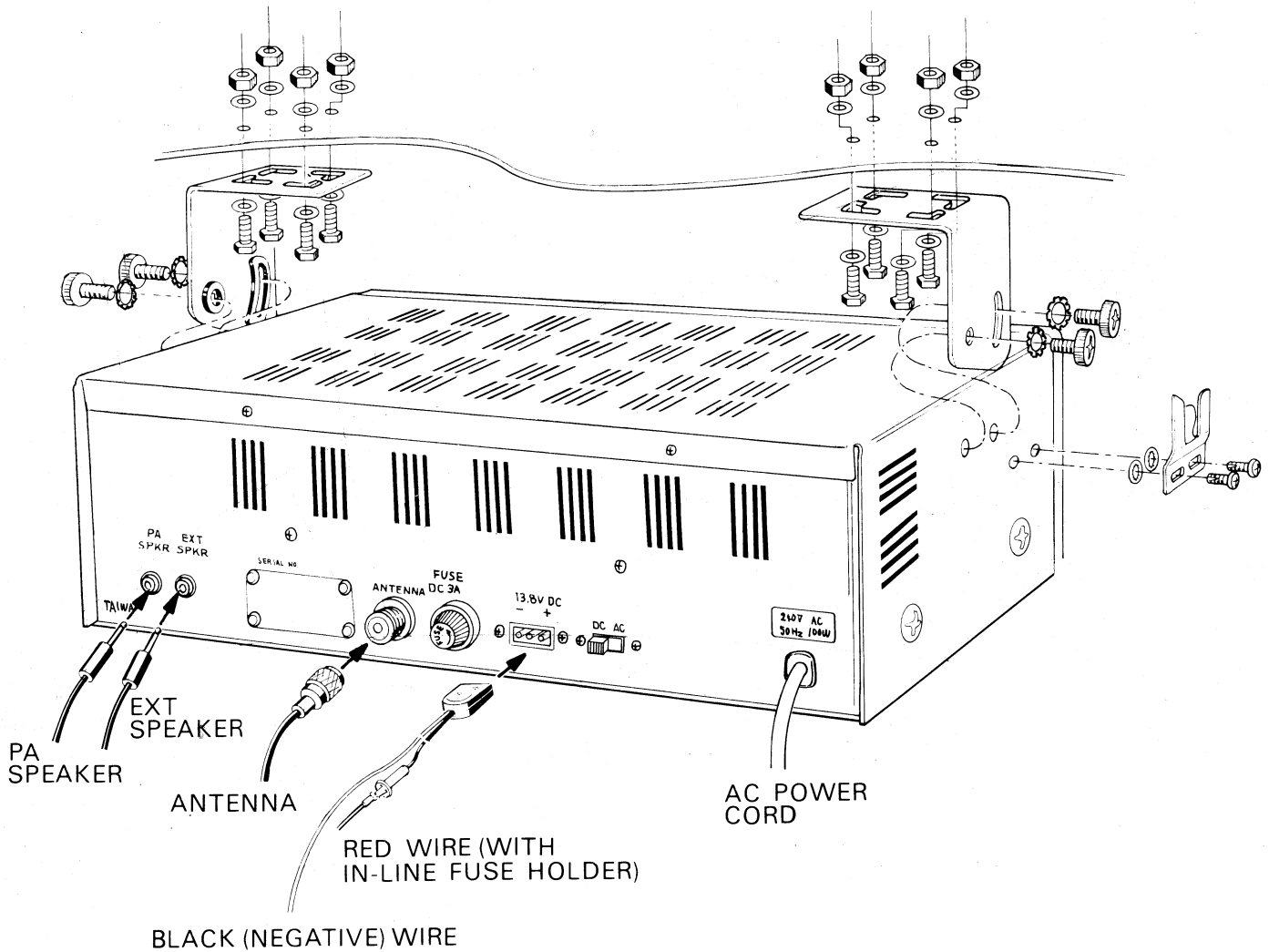

# ANTENNA SYSTEM

The antenna system includes the transmission line, and it is very important that you use the correct type of transmission line. The transmission line should be of the coaxial type and should have an impedance equal to the antenna impedance.

Since your Transceiver is designed to operate most efficiently into a 50 ohm load, it is best to use a type of coaxial cable with an impedance of 50 ohms. We suggest type RG-58/U for short lengths and RG-8/U for long lengths.

Generally speaking, you should keep the length of the transmission line to a minimum. Remember that line losses increase with frequency. Use foam-insulation coax for best results.

The above discussion is as important for reception as it is for transmission. If a mismatch exists between the antenna and the receiver, the excellent sensitivity and signal-to-noise ratio of the receiver circuitry will be defeated.

## FIXED STATION ANTENNAS

The most popular fixed station antenna is a complex colinear or ground plane.

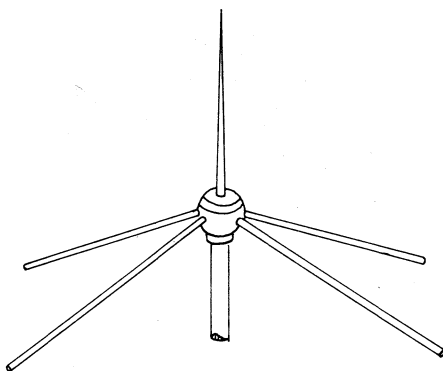

GROUND PLANE

## BASE STATION ANTENNA

Your TANDY store carries a complete line of base station CB antennas and accessories. For maximum efficiency, we strongly recommend using an SWR meter to aid in the proper matching between your antenna and Transceiver.

The antenna system should be adequately grounded.

Always use a lightning arrester for your antenna system.

Since the normal  $\frac{1}{4}$  wavelength whip antenna is too long (102" [2.6m]) for roof mounting on a vehicle, the antenna is shortened and a loading coil is utilized to provide the proper electrical length. As a result, the overall efficiency is reduced and the nondirectional advantage is defeated. Thus, a bumper mounted full-length whip antenna will normally give the best results.

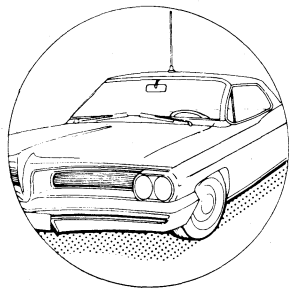

ROOF MOUNT

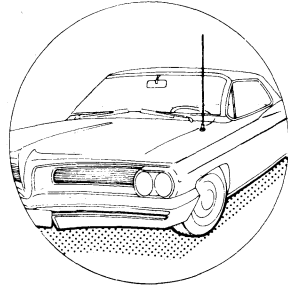

FRONT COWL MOUNT

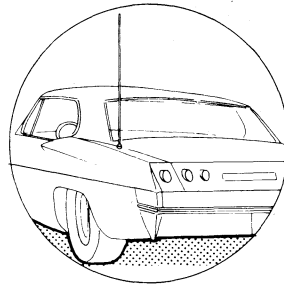

REAR DECK MOUNT

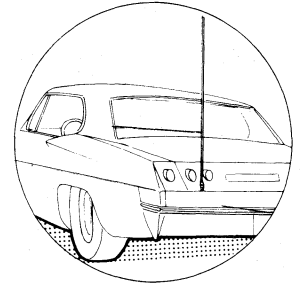

BUMPER MOUNT

A few general rules should be followed for proper installation of any mobile antenna:

1. Keep it as far as possible from the main bulk of the vehicle.
2. Keep as much of it as possible above the highest point of the vehicle or boat.
3. During operation, it must be vertical. Thus, it should be mechanically rigid so it will maintain a vertical position when the vehicle or boat is in motion.
4. Mount it as far as possible from sources of noise (ignition system, gauges, etc.) and convenient for transmission line routing away from these noise sources.

An antenna mounted in a boat requires a ground. This can be either the metal hull or a ground made of tin-foil or copper sheeting. This ground should cover an area of 12 square feet (1 m<sup>2</sup>) or more. Be sure the transceiver has an adequate ground as well. If you use TANDY's 102" (2.6 m) Fiberglass Marine Antenna (21-912), you won't need a ground; it has been designed with its own "ground" system.

## NOISE

Your vehicle or boat can be the cause of much noise interference. Your TRC-458-18 incorporates a switchable Automatic Noise Limiter circuit for AM and a Noise Blanker for both AM and SSB reception. Also, it has built-in power supply filtering. These circuits can help to reduce and/or eliminate annoying noise.

Remember, your transceiver has a very sensitive receiver and it will pick up even the smallest trace of ignition noise. Any noise that you hear in the transceiver is almost totally from external sources. The receiver itself is exceptionally quiet. Steady high noise levels can not be eliminated by the internal Automatic Noise Limiter and Noise Blanker circuits. Noise problems can not be solved internally (in the transceiver); they must be solved at the source of the noise.

If you wonder if the noise is from your ignition system, the transceiver or an external source, try this simple test. Turn your ignition switch off and set it to ACC (accessories). This turns off the ignition, but supplies power to the transceiver. Most of the noise will disappear—indicating that the source of noise is your ignition system.

This interfering noise can be generated anywhere in the electrical system of the vehicle or boat. The first step in reducing or eliminating this noise is to locate the source of the noise.

## IGNITION SYSTEM

The most common source of noise is the ignition system. This noise can be identified by the fact that, it varies with the speed of the engine. It consists of a series of popping sounds occurring at a regular rate that will vary with the speed of the engine and stop when the ignition is turned off.

There are a number of things that can be done to reduce this type of noise:

1. Use only the "radio suppression type" high voltage ignition wire. Most new cars come already equipped with this type of wire.
2. Inspect the high voltage ignition wire and all connections made with this wire. Old ignition wire may develop leakage, resulting in hash.
3. If noise still persists, replace the spark plugs with spark plugs that have suppressor resistors built-in. Be sure to use the correct type for your vehicle.

Other sources of noise are: generator/alternator, regulator, gauges and static discharge. Most of these types of noise can be effectively reduced or eliminated by using bypass capacitors at the various output voltage points. Once again, we suggest you check your TANDY store for a wide selection of noise reduction accessories.

# CONTROLS AND THEIR FUNCTIONS



This short description of the function of each control and jack supplies background information for proper operation. For actual Operating Instructions, refer to **Using Your Transceiver**.

**MICROPHONE** . . . The dynamic microphone must be connected to this jack. To Transmit, press the button on the mic and talk into the mic. To Receive, release the button.

When transmitting, hold the microphone at an angle, two or three inches (5–7.5 cm) from your mouth and speak clearly in a normal voice.

**PHONES** . . . Plug in communications type headphones for private listening, or in areas where background noise is excessive (factories, at the scene of an accident or fire, etc.). When you plug in the headphones, it automatically disconnects the internal speaker (or an external speaker).

**Channel Selector** . . . use to select any one of the standard 18 CB channels.

**VOLUME with "ON/OFF" switch** . . . Turn clockwise to apply power to the unit and then adjust for the desired level of sound from the speaker. When using PA it controls the level of the PA output.

**SQUELCH** . . . Sets the level of the internal Squelch circuitry to cut out the background noise when no signal is being received. When properly set, it allows signals to come through, but cuts off the receiver sound when no signal is being received, thus eliminating annoying background/atmospheric noise during standby and monitoring conditions.

If set too high, you may miss some of the weaker signals. Operating conditions will determine the best setting.

**RF GAIN** . . . Varies the sensitivity of the RF amplifier stages of the Receiver circuitry. For normal operation, set **RF GAIN** to maximum and adjust **VOLUME** for a suitable listening level. Under high-signal conditions, you may want to turn **RF GAIN** down a little and raise **VOLUME** as required.

**CLARIFIER** . . . Functions as a "fine tuning" (or "delta" tuning) for reception of Single Sideband and AM signals when the Mode switch is set to either **LSB** or **USB**. This permits you to tune your receiver to exactly the same frequency of any other station or stations which you are communicating with.

**AM-USB-LSB Mode Switch** . . . set this switch to the desired mode of operation for both transmit and receive. When in the AM position, both transmitter and receiver sections are operative for AM. When set to the LSB position, the Receiver operates to receive only the lower sideband portion of a signal; the Transmitter will transmit only the lower sideband of the modulated waveform. In the USB position, the Receiver operates only to receive the upper sideband portion of a signal; the Transmitter will transmit only the upper sideband of the modulated waveform.

**PA push-button** . . . Controls the function of the audio amplifier/modulation circuitry when the Microphone button is pressed. When the PA button is in the "out" position, the Microphone button turns the Transmitter on for normal transmissions. When you press the button in, the Transmitter will not function—the Microphone turns on the Public Address Amplifier function. For PA operation you must have a PA speaker connected to the PA jack on the rear chassis.

**NB push-button (Noise Blanker)** . . . Press in to cut out annoying impulse-type noise. Press again to release this function. This is particularly effective for ignition noise on both AM and SSB.

**ANL push-button (Automatic Noise Limiter)** . . . Press in to cut out annoying hash-type noises. Press again to release this function. This will be particularly effective for AM signals.

**RF-S Meter** . . . gives visual indication of signal strengths. When receiving, the RF-S Meter shows the strength of incoming signals; a change of one "S" unit indicates a change of 6 dB in signal strength. The meter is set up so that a 100 microvolt signal will produce a reading of S-9. When Transmitting, the RF-S meter gives a relative indication of output power from the Transmitter.

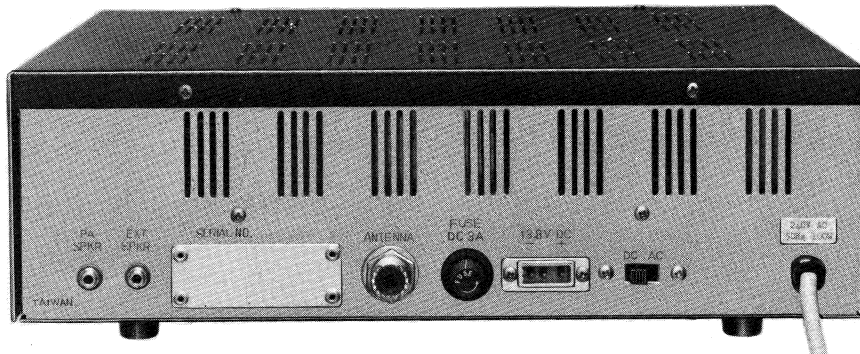

## THE REAR PANEL

**PA SPEAKER Jack** . . . connect an 8-ohm Public Address speaker to this jack for PA use. We recommend TANDY 40-1244, weatherized, rugged PA Speaker, as an ideal unit for either PA or External Speaker application.

**EXTERNAL SPEAKER Jack** . . . if you want to use an external speaker, plug it into this jack. You should use a standard 8 ohm type. When a standard (3.5 mm) phone plug is inserted into this jack, the built-in speaker is automatically disconnected.

**ANTENNA Coax Connector** . . . connect your CB antenna to this (SO-239 type, accepts PL-259 connectors).

**FUSE** . . . is for protection of the Transceiver and its source of AC power. If the Transceiver does not operate from AC power, check this fuse—replace only with the same type and value (3 amp).

**13.8V DC Connector and Power Cable with in-line fuse** . . . this cable is to be connected to a source of 12-16 volts DC power, negative or positive ground. The Red wire with the in-line fuse must be connected to the + side and the Black wire to the - side.

**240V AC Power Cord** . . . plug into source of 240 volts, 50 Hz AC power.

**DC-AC Switch** . . . selects the power source; DC or AC.

# USING YOUR TRANSCEIVER

**Note:** For detailed information on Installing, refer to INSTALLATION. Do not transmit without an Antenna or suitable load connected. Do not operate the PA function without a speaker connected to the PA SPKR jack.

Your Transceiver can be used either as a base or mobile unit.

**For base operation,** connect the AC power plug to a source of 240 volts, 50 Hz AC power. Set the DC-AC switch on the back of Transceiver to AC position. Connect coaxial transmission cable from your Antenna to the ANTENNA coax connector on the rear panel.

For most efficient operation and safety, use a separate ground wire connection between the chassis of your Transceiver and a cold water pipe or ground rod.

You can mount the Mobile Mounting Bracket under the Transceiver. The resultant slightly angled front panel will add to your operating convenience.

**For mobile operation,** use the 12 volt DC power cable, place the DC-AC switch in DC position. Also connect Antenna and ground and make all necessary mounting requirements.

## TO RECEIVE AM SIGNALS

1. Set **RF GAIN** control maximum clockwise.
2. Set **SQUELCH** control maximum counterclockwise.
3. Set Mode to **AM**.
4. Turn power "on" by rotating **VOLUME** clockwise.
5. Set **Channel Selector** to the desired channel.
6. Adjust **SQUELCH** to cut out annoying background noise when no signal is being received. To do this, set **Channel Selector** to a channel where no signals are present (or wait till signals cease on your channel). Then, rotate **SQUELCH** in a clockwise direction to the point where the background noise just stops. Now, when a signal is present, you will hear it, but will not be disturbed by noise on the channel in between signals.

When properly set, **SQUELCH** will keep the receiver "dead" until a signal comes in on that channel. Do not set **SQUELCH** too high, or weak signals will not be able to "open" the Squelch circuit. To receive weak signals, it is best to leave **SQUELCH** set to the minimum position (maximum counterclockwise).

7. Use **CLARIFIER** to tune in slightly off-frequency stations, or to tune out adjacent channel interference caused by a station on the next channel (which may be too close to your channel).
8. Adjust **VOLUME** for a suitable listening level.
9. Push **NB** button in if your reception is disturbed by interference from impulse-type noise (ignition noise and other man-made electrical noise). The Noise Blanker Circuitry is most effective with impulse noise.
10. Push **ANL** button in if your reception is disturbed by interference from hash-type noise (fluorescent lights and other types of constant broad-frequency type noise). The Automatic Noise Limiter circuit can reduce this type of noise.

**NOTE:** Under exceptionally high-noise conditions you may want to use both **NB** and **ANL**.

For most distinct reception, plug communications-type headphones (such as TANDY Catalog Number 279-200) into **PHONES** jack. This will be particularly helpful when operating in high noise surroundings (factory, construction site, etc.).

Often you'll find an external/remote speaker will be most advantageous. We've made provisions for connecting such a speaker—just connect it to the **EXT SPKR** jack on the back. TANDY sells a number of fine speakers for this purpose—we recommend Catalog Number 21-549. When you connect a speaker to this jack it automatically disconnects the internal speaker.



21 - 549

## TO RECEIVE SSB OR DSB SIGNALS

1. Set **RF Gain** maximum clockwise.
2. Set **SQUELCH** maximum counterclockwise.
3. Set **Mode** to either **LSB** (lower sideband) or **USB** (upper sideband), depending on which sideband is being used by the transmitting station.

**NOTE:** When receiving DSB (double sideband) signals, you can use either **LSB** or **USB**.

4. Turn power "on" by rotating **VOLUME** clockwise.
5. Set **Channel Selector** to the desired channel.
6. Adjust **SQUELCH** as noted above.
7. Use **CLARIFIER** to tune in the SSB signal.

SSB tuning takes practice; it is not difficult, it just takes a little experience. When first listening to an SSB signal, it probably will not be understandable; the voice may sound like "Donald Duck", or just low guttural sound. In either case, very slowly adjust **CLARIFIER** to bring the signal into its natural voice tonal range.

If the signal is Donald Duck type, tune so the signal tones become lower in tone; careful tuning will make the voice sound natural. If the signal is low and guttural, tune for higher tones.

- **NOTE:** If you try the above procedure and are not able to make the signal intelligible, it may be an SSB signal operating on the other sideband—try the other SSB Mode (**LSB** or **USB** as the case may be).
8. Adjust **VOLUME** for a suitable listening level.

Use **Noise Blanking** to (**NB**) reduce or eliminate noise interference. With SSB and DSB signals **ANL** will probably not be as effective as with AM signals. Use the position which results in greatest noise reduction.

## Notes on Receiving

An SSB signal will produce a fluttering, unintelligible sound when receiving in the **AM** mode; in such a case, use either the **LSB** or **USB** mode and adjust **CLARIFIER** for intelligibility.

You can tune AM signals when the **Mode** switch is in the **USB** or **LSB** position; tune **CLARIFIER** control to eliminate the steady tone caused by the AM carrier ("zero-beat" the tone so it disappears).

Remember that adjustment of **CLARIFIER** only shifts the Receiving frequency, **not** the Transmitting frequency.

When receiving an extremely strong SSB signal, you will find it best to use the **RF GAIN** control to vary the volume (rather than using **VOLUME**).

## TRANSMITTER OPERATION

1. Be sure PA button is out.
2. Plug the Microphone into the **MIC**rophone jack.
3. Set Mode Switch to the desired position.
4. Select the desired channel of operation.
5. Press the push-to-talk button on the side of the Microphone and speak in a normal voice into the Microphone. Best results will be obtained when you hold the mic 1 to 4" (2.5–10 cm) from your mouth and turned at about a 45° angle (not straight on).
6. When transmitting, the meters will turn red. The RF-S Meter will indicate the relative level of output power.
7. To receive, release the push-to-talk button.



## USING THE PUBLIC ADDRESS AMPLIFIER FEATURE

You can use your Transceiver to provide 4–6 watts of audio power as a Public Address amplifier. To use this function, you must connect an 8 ohm public address type speaker to the **PA SPeaKeR** jack on the rear of this unit. We recommend TANDY's 40-1244; it's a weatherized 4" (10 cm) speaker, specifically made for PA use.



40 – 1244

1. Be sure an 8 ohm speaker is connected to the **PA SPeaKeR** jack.
2. Push in **PA** button.
3. Turn the Transceiver "on" with the **VOLUME** control.
4. Connect the microphone and press the push-to-talk button and talk into the mic. Adjust **VOLUME** as required for the appropriate level of sound.
5. Even though you have your Transceiver set for PA operation, you can still monitor CB signals—press in both **PA** and **N.B.** buttons, and CB signals will be heard through the PA speaker. This way you won't miss any important calls, even while using PA. To defeat the receiver sound, press **NB** button again to release it.
6. To return to normal Transceiver operation, press **PA** button to release it.

# SSB (SINGLE SIDEBAND) . . . . WHAT IS IT?

We thought you'd be interested in knowing and understanding something about the SSB function and capability of your Transceiver.

To understand SSB, we need to know what an AM (Amplitude Modulated) signal is.

Amplitude Modulation is a form of heterodyning—mixing 2 signals together electrically. In the process of mixing, 3 signals result. Example:

An R.F. signal at 27.015 MHz (channel 1 C.B.) is mixed with (modulated by) a 1000 Hz tone.

The resulting signals—

27.015 MHz = original or "carrier" signal

27.015 MHz - 1000 Hz (27,015,000 minus 1000) = 27.014 MHz, the Lower Sideband

27.015 MHz + 1000 Hz (27,015,000 plus 1000) = 27.016 MHz, the Upper Sideband

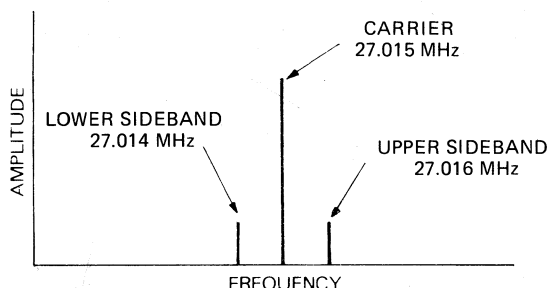

Notice that the communication or intelligence (the 1000Hz tone) is contained in each sideband. The Carrier contains no intelligence. This fact is vital!

For the sake of communication, all we need to receive is the 1000 Hz tone. The receiver only needs to recover one signal, and yet we are transmitting 3 signals. Not only are we sending 3 signals, but also we are wasting most of our power in one of them (which carries none of the intelligence, i.e. the carrier, 27.015 MHz) and the other two signals duplicate each other!

Thus, if we can eliminate the carrier (not needed for communication) and can send only one of the sidebands (since they duplicate each other's information anyway), we could concentrate all of the transmitting power into one sideband. This is exactly what Single Sideband accomplishes.

Single Sideband transmissions incorporate only **one** of the sidebands—i.e. in the example above, **only** the upper sideband at 27.016 MHz or **only** the lower sideband at 27.014 MHz. The second sideband and the carrier are eliminated in the early stages of the transmitter circuitry.

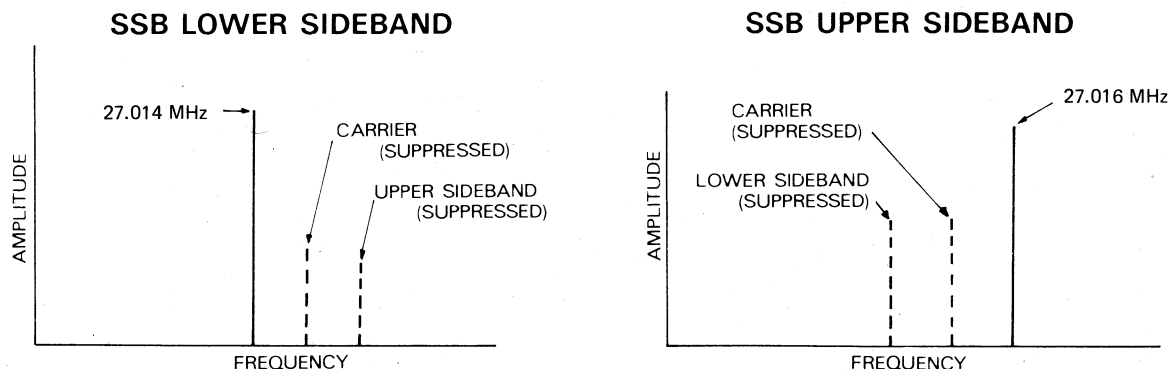

When only one sideband is transmitted, we can concentrate all of the available power in this one sideband, greatly increasing the effective power of an SSB signal as compared to an AM signal.

See Advantages of SSB Over Normal AM.

## ADVANTAGES OF SSB OVER NORMAL AM

A theoretically perfect AM transmitter used in Citizens Band Radio Service as permitted by the P.&T. will have the following maximum output power specification:

Carrier --- 4 watts with the capability of slightly less than 100% modulation

In order to fully Amplitude Modulate a 4 watt carrier, a full 2 watts of audio power is required. In this case, only 1 watt of power can exist in each sideband. Since the carrier contains no intelligence, and the sidebands duplicate each other, really only one sideband is required to transmit the required intelligence.

If we take the above transmitter and convert it to Double Sideband operation (eliminate the carrier power), we can increase the power in the sidebands to 2 watts each, without overloading the circuitry. Further, if we eliminate one of the two sidebands, we can put the full 4 watts of power into remaining sideband. Thus, while an AM transmitter has only 1 watt of power in one sideband, an SSB transmitter can have 4 watts of power in one sideband—or **4 times the power of an AM transmitter.**

Thus, effectively an SSB transmitter with the same power limitations is 4 times more powerful than an AM transmitter.

One further advantage, which is not often mentioned. Not only does the SSB signal take up only 1/2 of the frequency spectrum space of an AM signal (only 1 sideband instead of 2), thus permitting twice the number of stations to be in the same amount of band space—but also, at the receiving end, the receiver only picks up 1/2 of the total AM bandwidth. This means that 50% less noise is amplified along with the signal. This results in a 50% improvement in signal-to-noise figures; or, in more technical terms, a 3 dB improvement.

Thus, given equal limitations and conditions, an SSB signal will be 4 times more powerful and will have 2 times the signal-to-noise advantage of an AM signal—**8 times as effective.**

In technical terms, a 9 dB advantage. Thus, for an AM transmitter to be equivalent in effectiveness it would have to be rated at 32 watts!

Enough said! We hope you're enthused.

# MAINTENANCE

Since only the finest quality parts are used throughout your Transceiver (and these are all conservatively rated), you will need little or no service or repair of the unit.

Be sure you treat it with the care deserving of such a piece of electronic equipment. It is rugged and designed for either base or mobile use—but do not abuse it. Be sure you always make proper connections and adequate mounting provisions.

**If you run into problems with the unit, we recommend you check the following:**

1. If trouble is experienced with receiving.
  - Check the **VOLUME** On/Off switch setting.
  - Be sure **SQUELCH** is adjusted properly. Is it over-squelched?
  - Check if the unit is switched to an operating channel.
2. If trouble is experienced with transmitting.
  - Check if the transmission line is securely connected to the ANTenna Connector.
  - Check to be sure the antenna is OK.
  - Are all transmission line connections secure and free of corrosion?
  - Make sure you are fully depressing the Push-To-Talk Button on the Mic.
  - Be sure Mic connector is firmly pressed into its jack.
3. If the transceiver is completely inoperative.
  - Check the power cable and in line fuse (3A).
  - Be sure DC-AC switch is in correct position.

If these checks don't solve the trouble, do **NOT** attempt repairs or adjustments yourself. The unit should be serviced only by a qualified radio technician. Whenever possible, return the unit to the store from which it was purchased.

## WARNING

Do not open up the Transceiver to make any internal adjustments. Internal adjustments and/or modifications can lead to illegal operation as defined by P. & T., Rules and regulations. Such illegal operation can lead to very serious consequences.

# BLOCK DIAGRAM

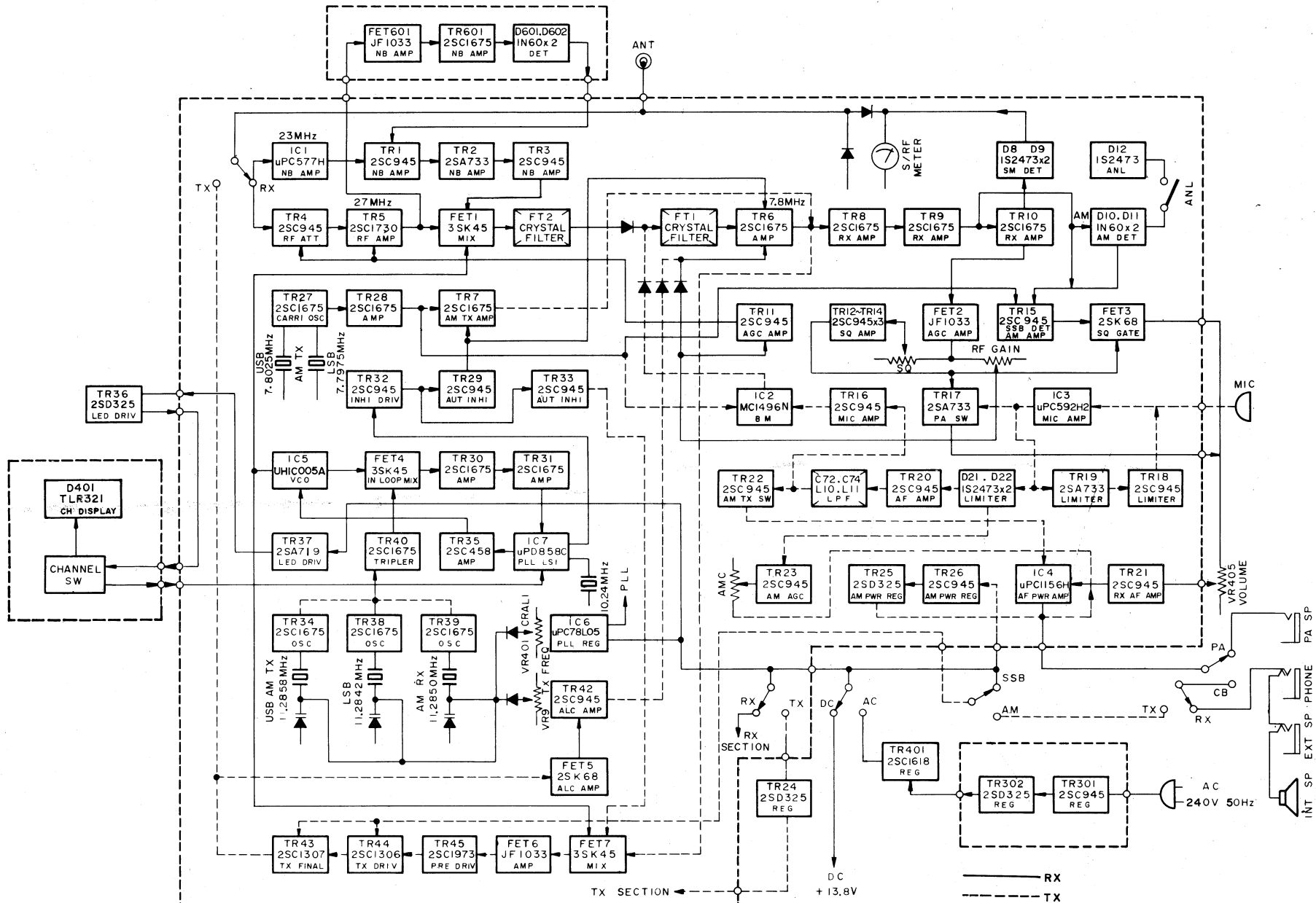



### TANDY LIMITED WARRANTY

This equipment is warranted against defects for 90 days from date of purchase. Within this period, we will repair it without charge for parts and labor. Simply **bring your sales slip** as proof of purchase date to any TANDY store. Warranty does not cover transportation costs. Nor does it cover equipment subjected to misuse or accidental damage.

*We Service What We Sell*

For service, return this set to your nearest TANDY ELECTRONICS store.

### TANDY CORPORATION

#### AUSTRALIA

Head Office:  
TANDY CORPORATION  
280-316 VICTORIA ROAD  
RYDALMERE, N.S.W. 2116

#### BELGIUM

PARC INDUSTRIEL DE NANINNE  
5140 NANINNE

#### U. K.

BILSTON ROAD  
WEDNESBURY, STAFFS WS10 7JN