

REALISTIC[®]

Service Manual

21-139/141

TRC-9A/11

3-CHANNEL / 6-CHANNEL C.B. MOBILE TRANSCEIVER

Catalog Number: **21-139/141**



CUSTOM MANUFACTURED FOR RADIO SHACK  A TANDY CORPORATION COMPANY

CONTENTS

	Page
1. SPECIFICATIONS	1
2. CRYSTAL LOCATIONS	1
3. CHASSIS DISASSEMBLY	2
4. GENERAL ALIGNMENT INSTRUCTIONS	3,4
5. ALIGNMENT POSITION	4
6. BLOCK DIAGRAM	5
7. WIRING DIAGRAM	5
8. P.C. BOARD (TOP VIEW)	6
9. P.C. BOARD (BOTTOM VIEW)	6
10. TROUBLE SHOOTING	7
11. PARTS LIST	8~12
12. SUB P.C. BOARD	12
13. SUB P.C. BOARD PARTS LIST	13
14. SEMICONDUCTOR LEAD IDENTIFICATION	13
15. SCHEMATIC DIAGRAM FOR SUB P.C.BOARD	13
16. SCHEMATIC DIAGRAM (TRC-9A)	14
17. SCHEMATIC DIAGRAM (TRC-11)	15

SPECIFICATIONS

Description	Nominal spec.	Limit spec.
Frequency range	26.965–27.255 MHz	
Channels	3 channels TRC-9A (21–139) 6 channels TRC-11 (21–141)	
Frequency tolerance	Less than $\pm 0.005\%$	
Operating voltage	13.8VDC $\pm 10\%$	
Sensitivity	0.7 μ V at 10 dB	1.5 μ V at 10 dB
Selectivity	–33 dB at ± 10 kHz	–30 dB at 10 KHz
Intermediate frequency	455 kHz with ceramic filter	
Signal to noise ratio	More than 40 dB at 1mV input	
Squelch sensitivity	Threshold less than 1 μ V Tight 500 μ V	Tight 50 μ V–3mV
Audio output	1.2 watts, Max. power 10% distortion 1 watt	More than 0.8 watt More than 0.65 watt
RF output	3 watts	2.5 watts
Power input	5 watts max.	
Modulation	Below 100%	
Antenna impedance	50 ohms (unbalanced)	
Speaker impedance	8 ohms, 2-1/4" Dynamic type	
Dimensions	4-1/4" (W) x 6-1/2" (D) x 1-3/4" (H)	

CRYSTAL LOCATIONS

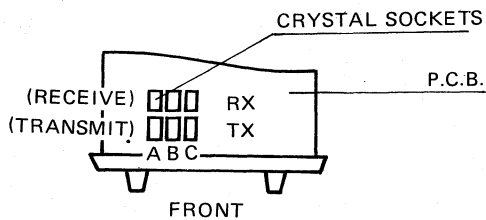
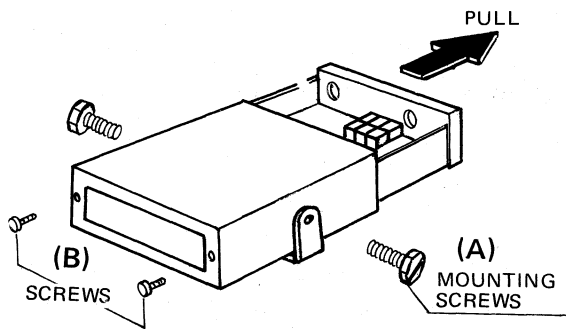

TRC-9A

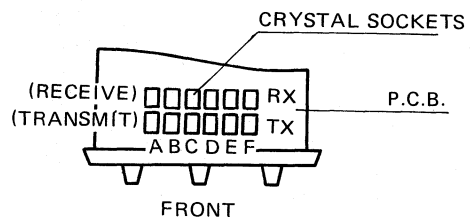
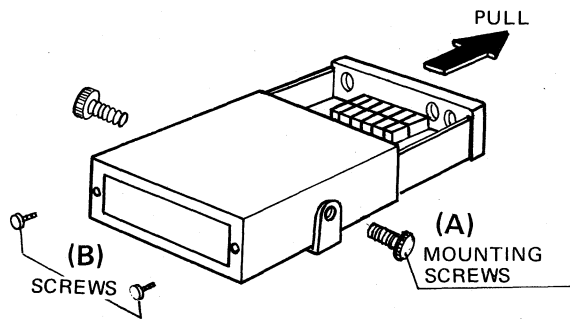

TRC-11

CHASSIS DISASSEMBLY

Removal of the cabinet:

- Step 1: Remove 2 mounting bracket screws(A) as shown and remove the mounting bracket.
- Step 2: Remove 2 screws(B) as shown from the rear.
- Step 3: Pull out the chassis from the front.

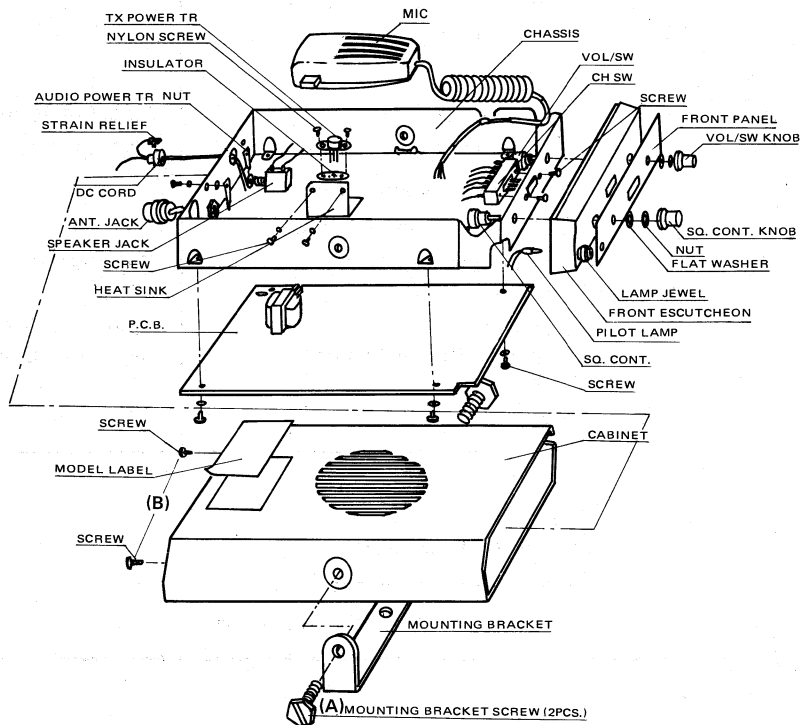

TRC-9A

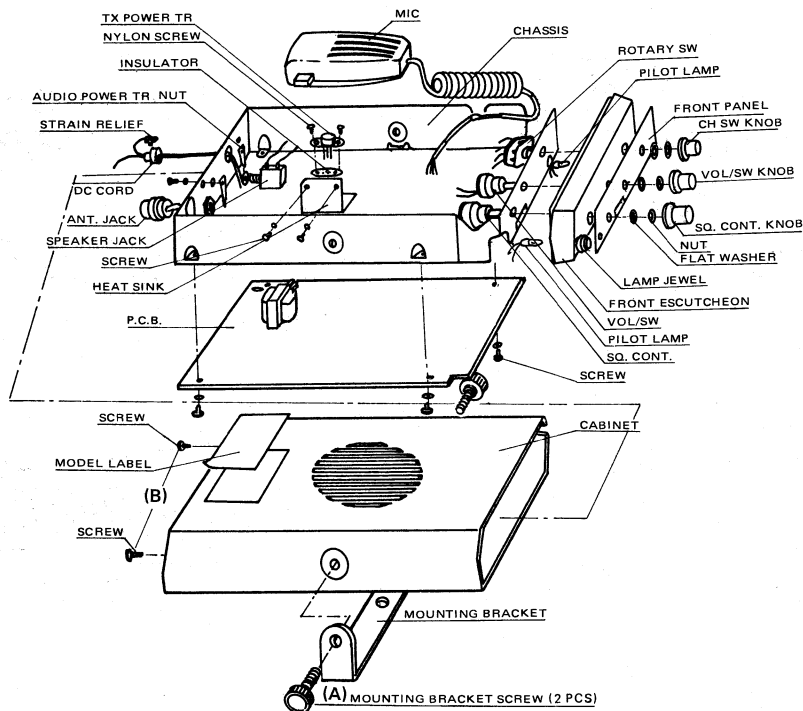

TRC-11

GENERAL ALIGNMENT INSTRUCTIONS

Test equipment required

- 1 RF standard signal generator (S.S.G.)
- 2 AF signal generator
- 3 V.T.V.M.
- 4 RF power meter
- 5 Oscilloscope
- 6 Monitor receiver
- 7 Frequency counter
- 8 1A DC ammeter
- 9 8 ohm dummy load

Note: Keep the input signal from S.S.G. as low as possible during all alignment.

RECEIVING SECTION ALIGNMENT CHART

STEP	CONTROL SETTING	TEST EQUIPMENT CONNECTION	SIGNAL GENERATOR SETTING	ADJUST	REMARKS
1	Volume control: Fully clockwise SQ control: Max. counter-clockwise CH: A position 27.065 MHz (TRC-9A) 27.085 MHz (TRC-11)	V.T.V.M.: Parallel with 8 ohm dummy load connected to J2 Signal generator: through 100 pF to the base of Q2 2SC371	Freq: 455 kHz Mod.: 1 kHz 30%	T3 (YEL) T4 (WHT) T5 (BLK)	Max. output on voltmeter
2	"	V.T.V.M.: Parallel with 8 ohm dummy load connected to J2 Signal generator: to J1	Freq.: 27.065MHz (TRC-9A) 27.085MHz (TRC-11) Mod.: 1 kHz	T1, 2	Max. output on voltmeter
3	Volume control: Adjust for desired audio level SQ. Control: Fully clockwise	V.T.V.M.: Parallel with 8 ohm dummy load or across speaker to J2 Signal generator to J1	Freq.: 27.065MHz (TRC-9A) 27.085MHz (TRC-11) Mod.: 1kHz 30% Output: 500 μ V	R34	Adjust so squelch just opens

TRANSMITTING SECTION ALIGNMENT CHART

STEP	CONTROL SETTING	TEST EQUIPMENT CONNECTION	TEST EQUIPMENT SETTING	ADJUST	REMARKS
1	CH: A position 27.065MHz (TRC-9A) 27.085MHz (TRC-11)	Power meter (50 ohms): to J1 1A ammeter: in series with lead between modulation winding of T8 and collector of Q14 Oscilloscope: in parallel with power meter	Supply voltage: 13.8 volts		
2	Press the P.T.T. SW.	"	"	T9, 10	Max. power output
3	"	"	"	L5, 6	Peak on the Power meter and dip on the ammeter to get 3 watts output at J1 (or max output)
4	"	Power meter (50 ohms): to J1 1A ammeter: in series with lead between modulation winding of T8 and collector of Q14.	Vary supply voltage from 15 to 12 volts.	T9	If no output, adjust T-9 to assure output at both voltage extremes.
5	"	Audio frequency generator: to C23 (or talk into Microphone).	Reset the supply voltage to 13.8 volts.		Check modulation
6	Repeat steps 2 to 4.				

ALIGNMENT POSITION

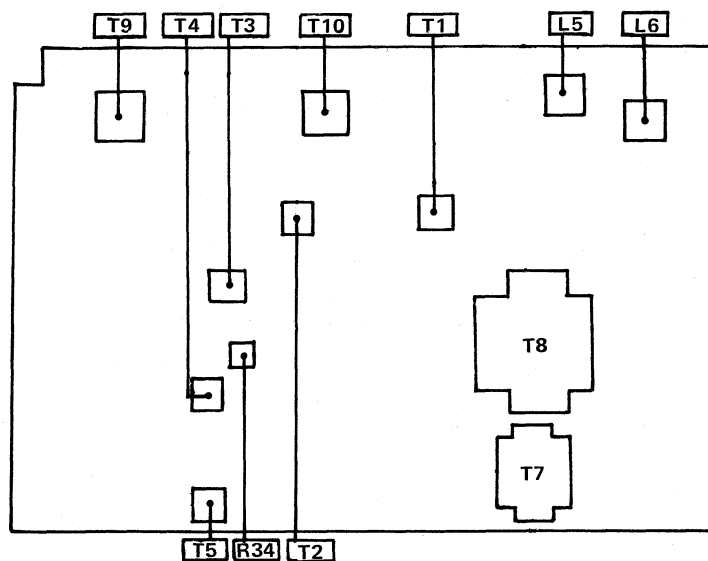

BLOCK DIAGRAM

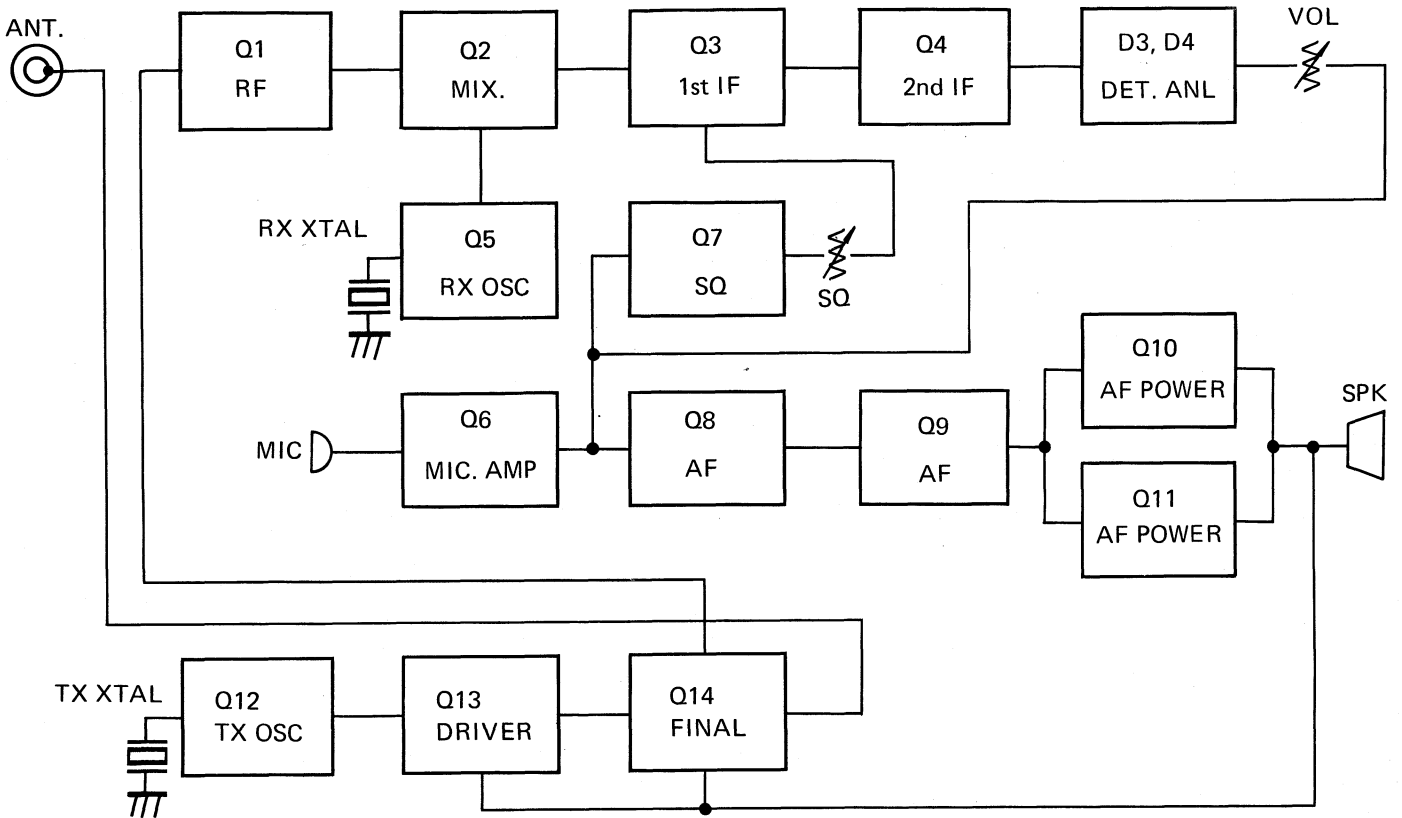

TRC-9A and TRC-11

WIRING DIAGRAM

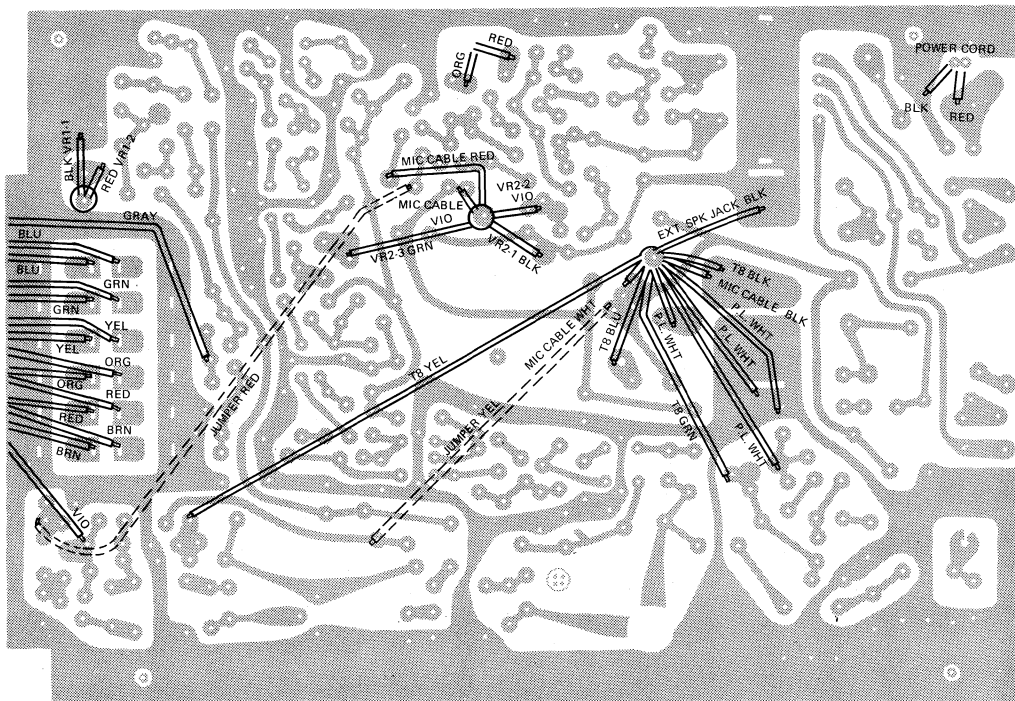

Note: 6 crystal sockets with lead wires (wires color BRN, RED and ORG.) are TRC-9A.

TROUBLE SHOOTING

Symptom	Possible cause
1) Pilot lamp and channel indicator (TRC-11 only) lamps do not light and set does not operate when power is on.	A) Faulty power cord. B) Defective power switch SW2. C) 2A fuse blown.
2) Fuse blows when power switch is on.	A) Defective Electrolytic capacitor. B) Defective audio power amplifier transistor Q10 or Q11. C) Defective TX final Transistor Q14 or Q13. D) Defective zener diode D7.
3) Pilot lamp or channel indicator lamp (TRC-11 only) does not light.	A) Defective pilot lamp or resistor R63. B) (TRC-11 only) Defective channel indicator lamp or resistor R64. C) Short circuit in the B+ Circuit.
4) Pilot lamp comes on but no sound on any channel.	A) Faulty EXT. Speaker jack J2. B) Poor crystal socket contact or crystal loose in socket. C) Defective zener diode D5. D) Weak crystal.
5) Transmitter does not operate or no modulation.	A) Faulty P.T.T. switch. B) Defective microphone cartridge. C) Faulty transistor Q12, 13, or Q14. D) Faulty microphone cord. E) Defective T8 Transformer modulation winding. F) Defective resistor R57 or R59. G) Faulty transistor Q6 or Q7.
6) Squelch control does not operate.	A) Defective transistor Q7. B) Faulty VR2 or R34.

Ref. No.	Description	RS Parts Number	MFR's Parts Number
Lamp 1	Channel switch Knob (TRC-11 only) Pilot Lamp 7V 50mA L=190mm	K-1074 L-0263	GE-18D-4433
Lamp 2	Channel indicator lamp (TRC-11 only) 7V 50mA L=190mm Lamp Jewel Lamp Holder (TRC-11 only)	L-0263 HB-0706	GE-17D-3438 LH-141
J1	Fuse 2A P.C. Board	X-4269	GE-18C-4305
J2	Antenna jack connector	J-6244	SO-239 273
SPK	Speaker Jack Speaker	J-0592 S-4335	JA-C-011 P0642AA
	Line cord strain relief Rubber bushing Rubber bushing (New type)	HB-0705	SR-3P-4 GE-15D-2699 GE-19D-4607

FOR CANADIAN/D.O.C. MODELS ONLY

SUB P.C. BOARD NOTE: Modulation limiting stage for Canadian model TRC-9A and TRC-11

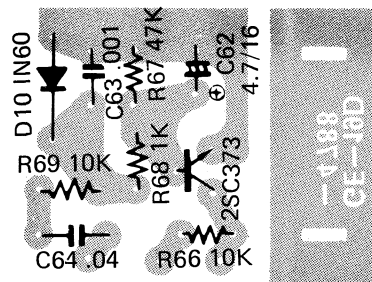
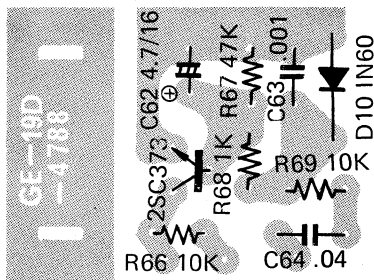

SUB P.C. BOARD WIRING DIAGRAM

(TOP VIEW)

(BOTTOM VIEW)

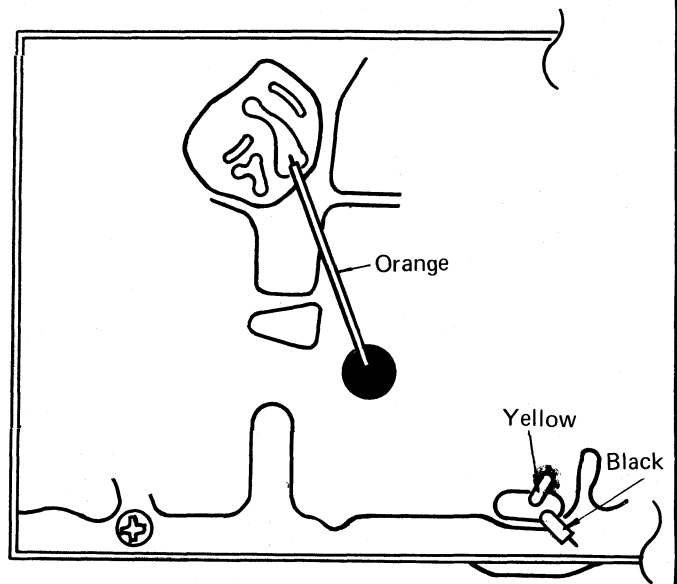
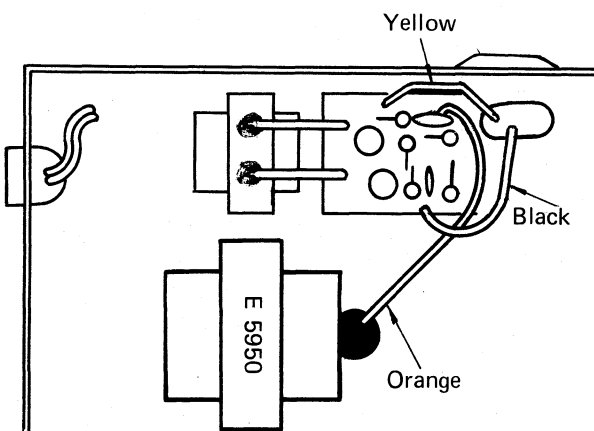

SUB P.C. BOARD PARTS LIST

(Modulation limiting stage for Canadian model TRC-9A and TRC-11)

Ref. No.	Description	RS Parts Number	MFR's Parts Number
CAPACITORS			
C62	Electrolytic 4.7 μ F/16VV		CE04W IC470B
C63	Ceramic 0.001 μ F		MC-60
C64	Ceramic 0.04 μ F		MC-100
RESISTORS			
R66, 69	Carbon film 10K Ω 1/4W \pm 5%		ELR 1/4 103J
R67	Carbon film 47K Ω 1/4W \pm 5%		ELR 1/4 473J
R68	Carbon film 1K Ω 1/4W \pm 5%		ELR 1/4 102J
SEMICONDUCTORS			
Q15	Transistor, Silicon, Toshiba		2SC373
D10	Diode, Silicon		1N60
MISCELLANEOUS			
	P.C. Board		GE-19D-4788

SEMICONDUCTOR LEAD IDENTIFICATION

- (A) : 2SC371, 372, 373, 735, 784
 (B) : 2SA699 (C) : 2SC1239 (D) : 2SC1018
 (E) : 2SC756 (F) : 2SC1364 (G) : 2SC1728

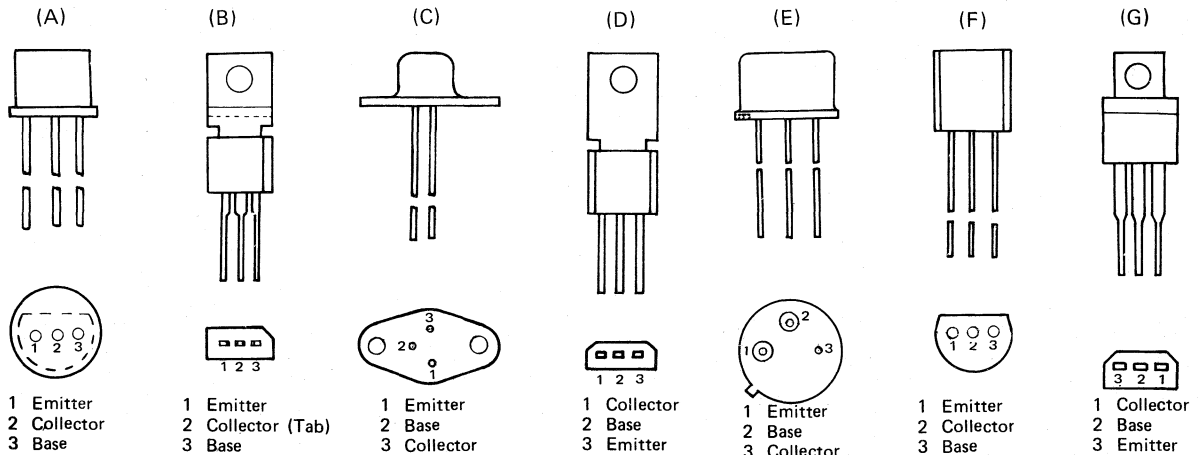

SCHEMATIC DIAGRAM FOR SUB P.C. BOARD

NOTE: Modulation limiting stage for Canadian model TRC-9A and TRC-11.

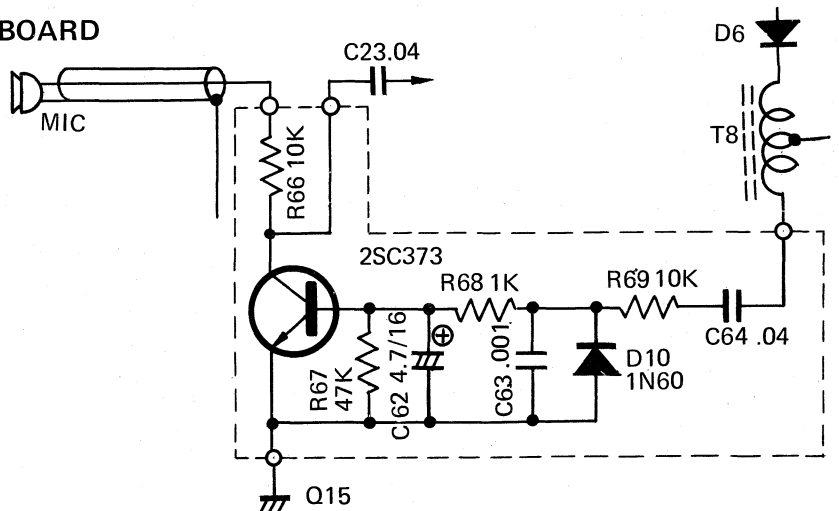

SCHEMATIC DIAGRAM

Q1 2SC784(R)

Q2 2SC371(O)

Q3 2CS372

Q4 2SC372

(7.0)

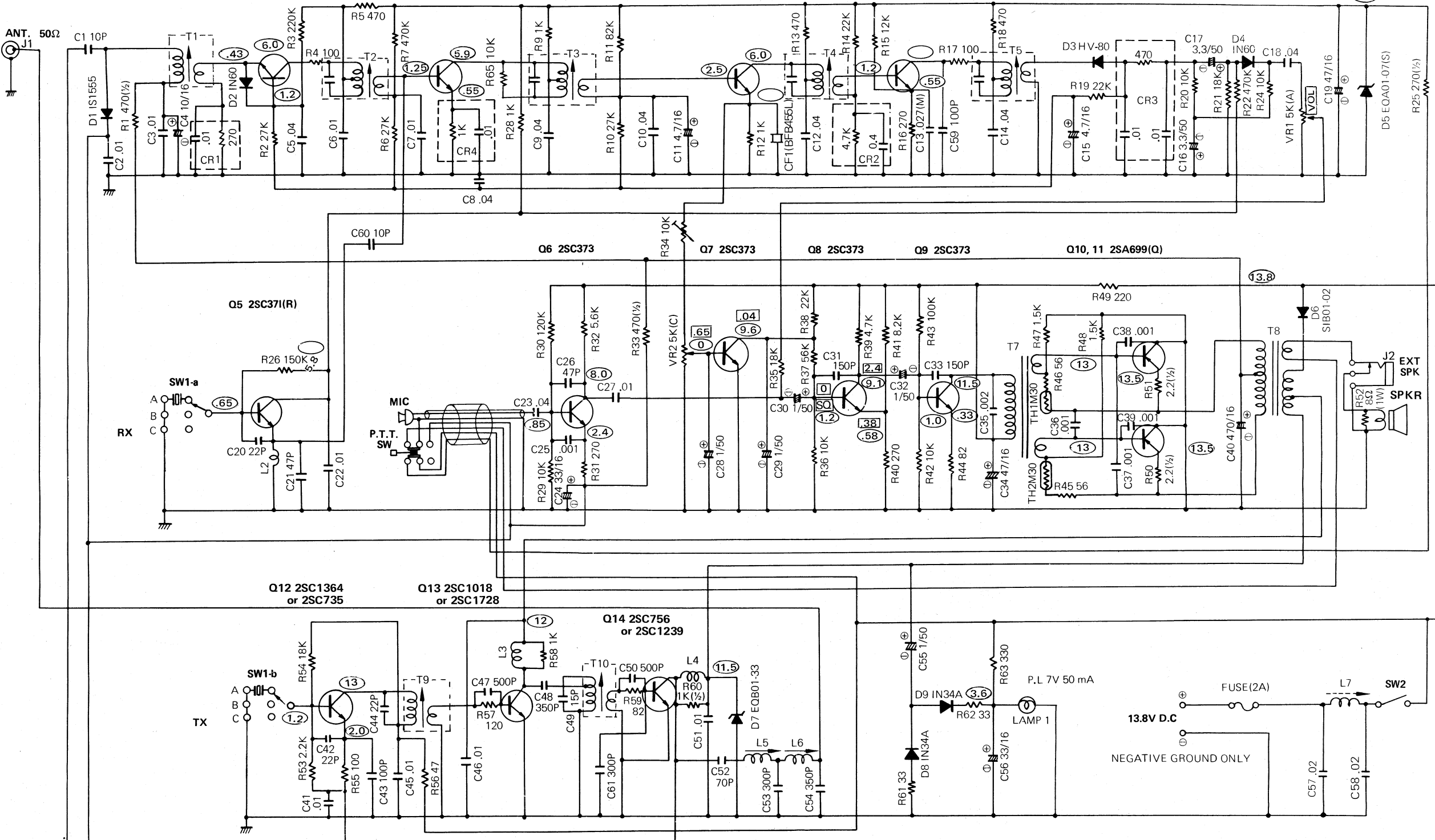

NOTE:

1. SW1a-b: CHANNEL SW.
2. SW2: POWER SW W/VR1
3. RESISTANCE VALUES IN OHMS.
K=1000
4. CAPACITANCE VALUES IN MF.
P=MMF
5. VOLTAGES ARE MEASURED WITH V.T.V.M.
UNDER FOLLOWING CONDITIONS:
VOLUME MINIMUM
SQUELCH MAXCLOCKWISE.

TRC-9A
CAT.No. 21-139

SCHEMATIC DIAGRAM

Q1 2SC784(R)

Q2 2SC371(O)

Q3 2CS372

Q4 2SC372

SW3
ANL
OFF ON

(7.0)

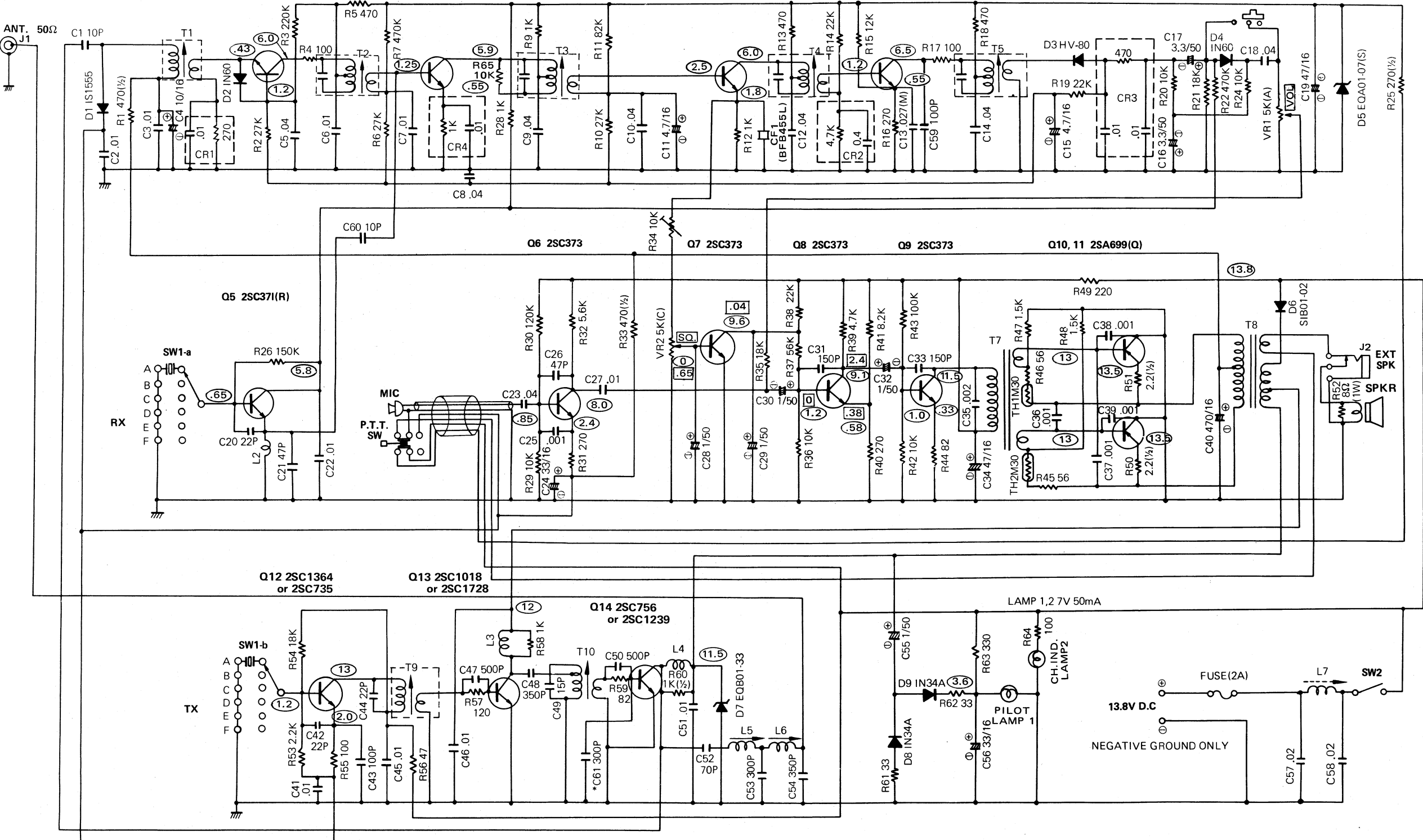

NOTE:

1. SW1a-b: CHANNEL SW.
2. SW2: POWER SW W/VR1 VOL. CONT.
3. RESISTANCE VALUES IN OHMS unless otherwise indicated (K=1000).
4. CAPACITANCE VALUES IN MF unless otherwise indicated (P=MMF).
5. VOLTAGES ARE MEASURED WITH V.T.V.M. UNDER FOLLOWING CONDITIONS:
VOLUME MINIMUM
SQUELCH MAX. CLOCKWISE.

TRC-11
CAT.No. 24-141

RADIO SHACK  A TANDY CORPORATION COMPANY
U.S.A.: FORT WORTH, TEXAS 76107
CANADA: BARRIE, ONTARIO, CANADA L4M 4W5

TANDY CORPORATION

AUSTRALIA

**280-316 VICTORIA ROAD
RYDALMERE, N.S.W. 2116**

BELGIUM

**PARC INDUSTRIEL DE NANINNE
5140 NANINNE**

U. K.

**BILSTON ROAD
WEDNESBURY, STAFFS WF10 7JN**