

Vintage Radio

By RODNEY CHAMPNESS, VK3UG



The Kriesler 41-29 “Trans-Mantel”

Developed during the early 1960s, the Australian-made Kriesler 41-29 “Trans-Mantel” was a 7-transistor receiver based on PNP germanium transistors. It was an excellent little set that could be used both as a mantel receiver and as a portable.

THE TRANSISTOR RECEIVER era effectively started in Australia with the importation of a number of radios from Japan in the mid-1950s. These early sets were not brilliant performers as I soon found out when I bought a small Sony pocket receiver. It proved to be extremely “hissy”, even when tuned to a strong local station. In

fact, the signal had to be quite strong for the set to even receive it.

Despite these shortcomings, I became hooked on this new technology – a technology I didn’t understand at the time but wanted to learn about. I kept the little pocket set for a quite few years but its limitations meant that it had very little use and I mostly listened

to my old faithful valve radios.

Australian manufacturers started making transistor receivers in the late 1950s. Initially, they assembled the sets in the same way as their valve sets, with point-to-point wiring, and in some radios, the transistors were even mounted in special sockets – just like valves. This method of manufacture was expensive, particularly when Australian manufacturers had to compete with the Japanese manufacturing techniques of PC board construction and cheap employee wages.

However, Australian manufacturers quickly realised that transistors should be treated as just another component. Mounting most of the receiver on a PC board would also be cheaper, with fewer wiring mistakes. These techniques coupled with tariff barriers helped Australian manufacturers stay competitive until the barriers were reduced in the early 1970s.

The transitional Kriesler

Kriesler Australia was one of many firms making both valve and transistor sets in the 1960s. Like most manufacturers at that time, they built their transistor receivers in a style that suited valve technology.

Just why they did this isn’t clear. It’s hard to be sure whether the manufacturers were ultra-conservative when it came to designing their radios (cabinets in particular) or whether they felt that customers would not accept the styling changes that were possible with transistors (including portability). In reality, it was probably a combination of both scenarios.

The 41-29 is one of these transitional receivers, being called a “Trans-Mantel”. It is in a case similar to the Kriesler 11-90 valve mantel receiver, although the dial mechanism is quite different. It could be used either as a



This is the fully-restored set, shown here with its carrying handle raised. Its styling resembled the earlier valve mantel receivers.

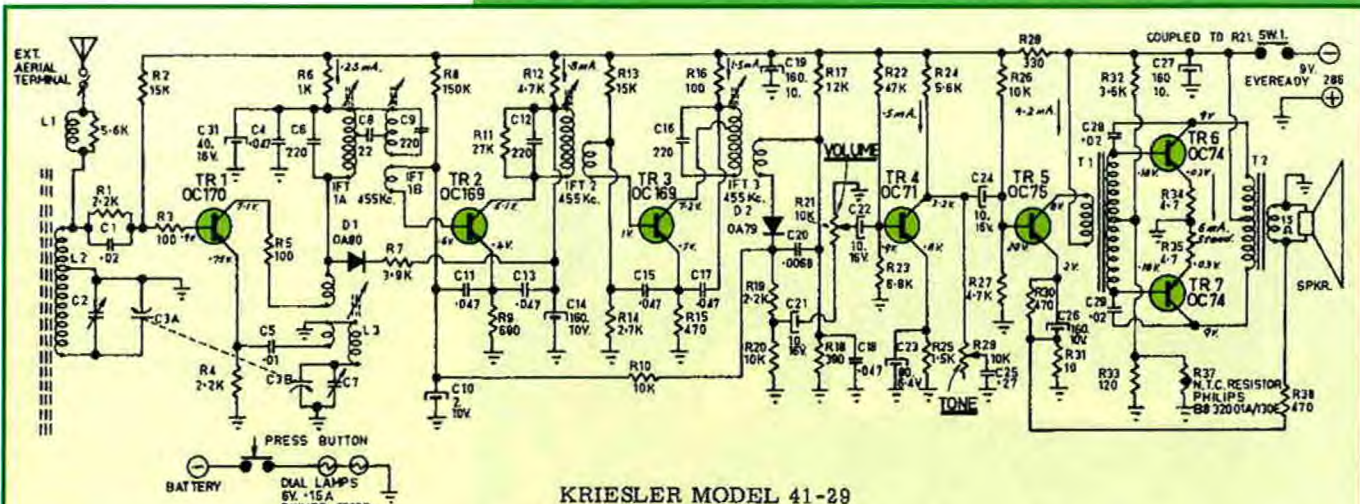

Fig.1: the Kriesler Model 41-29 employed a conventional superhet circuit based on seven PNP germanium transistors.

conventional portable (although the cabinet may not be all that rugged) or as a cordless mantel receiver.

Unlike some other sets, the battery life was quite good, as a 286 battery was used to provide power. The 286 was in reality two 276 type batteries in the one case. In fact, a life of up to 1000 hours has been quoted for this battery in some of the Kriesler receivers.

Main features

The Kriesler 41-29 is housed in an attractive plastic case and its size suited both portable or mantel-piece operation. It has a large slide-rule dial and is tuned by a relatively large knob at the righthand end of the scale.

Apart from that, there are just two other controls: a combined on-off/tone control and a volume control at bottom right. It all adds up to a rather neat and functional layout.

The rear of the set is held in place by two screws, which serve dual functions. When viewed from the back, the lefthand screw is also the antenna connection, while the righthand screw serves as the earth connection.

It is necessary to remove these two screws and the back to replace the battery. In fact, the instructions for this are on a small piece of paper attached to the underside of the receiver. Another set of instructions, this time inside the back, describe how the rest of the receiver can be dismantled.

This same piece of paper also has a layout diagram of the major parts on the PC board, plus a rather small copy of the circuit. This circuit is hard to

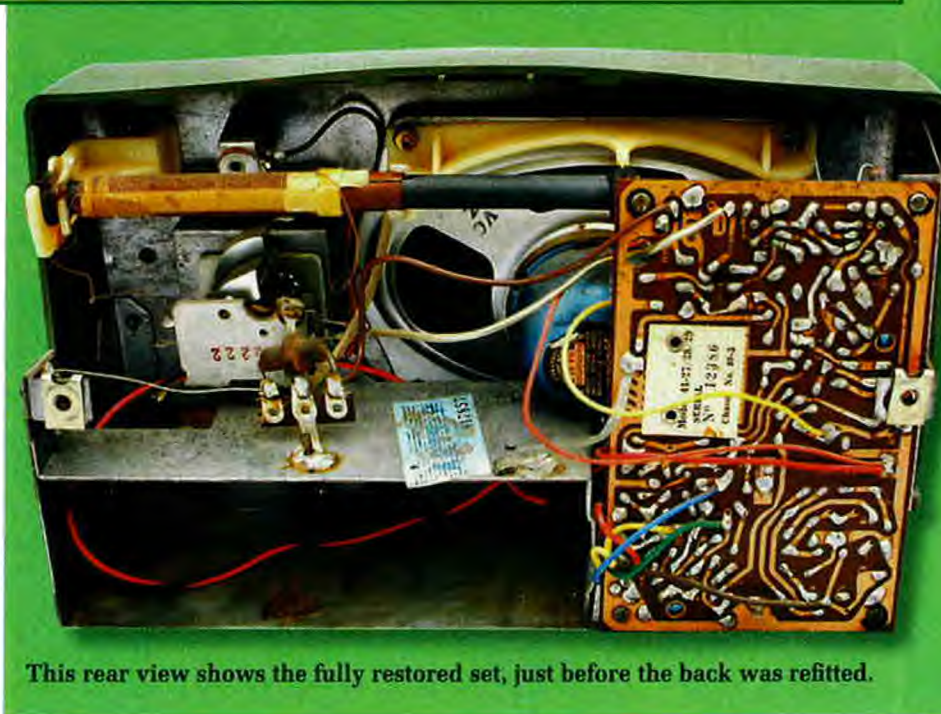

read because of its small size but it's much better than having no information at all about the circuitry.

Dismantling and cleaning

The two control knobs fitted to the unit that was given to me to restore were certainly not the originals. They were both black and much bigger than the originals that came with the set, so they certainly looked out of place.

Fortunately, I had some old Kriesler knobs stashed away and I found two which looked similar to the original knobs. The two black control knobs and the tuning knob were then removed, followed by the four screws

that secured the chassis to the front of the cabinet. That done, the front of the cabinet came away in three separate pieces (that's how it was made).

The chassis was dusty but a few minutes work with an old paintbrush fixed that. The dial pulleys were then oiled, as were other moving parts.

In this set, the volume and tone control shafts are split down the centre and require a knob with a metal insert (this insert anchors to the sides of the knob). The Kriesler knobs that I'd dug up (originally scrounged from a Kriesler TV set) were suitable but to accommodate the metal inserts, I had to increase the width of the slots (the

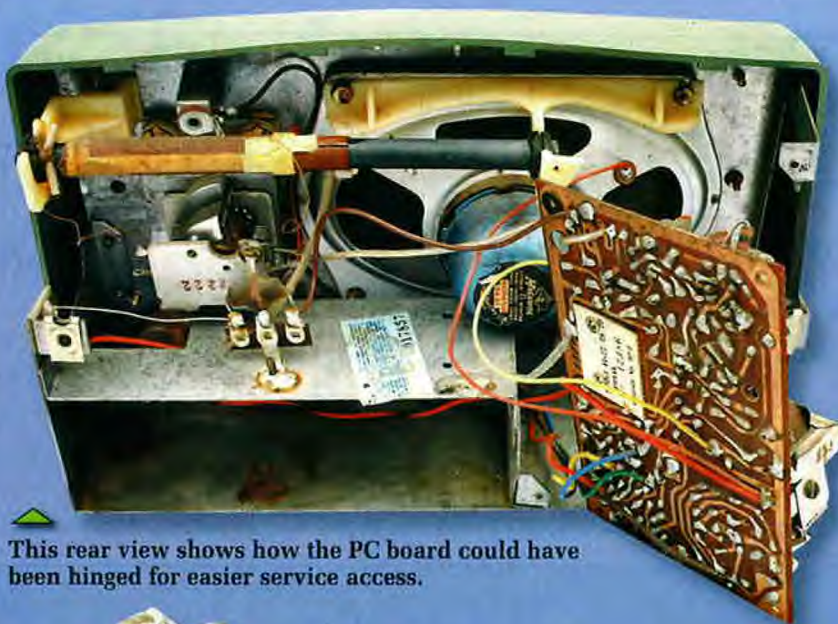

▲ This rear view shows how the PC board could have been hinged for easier service access.

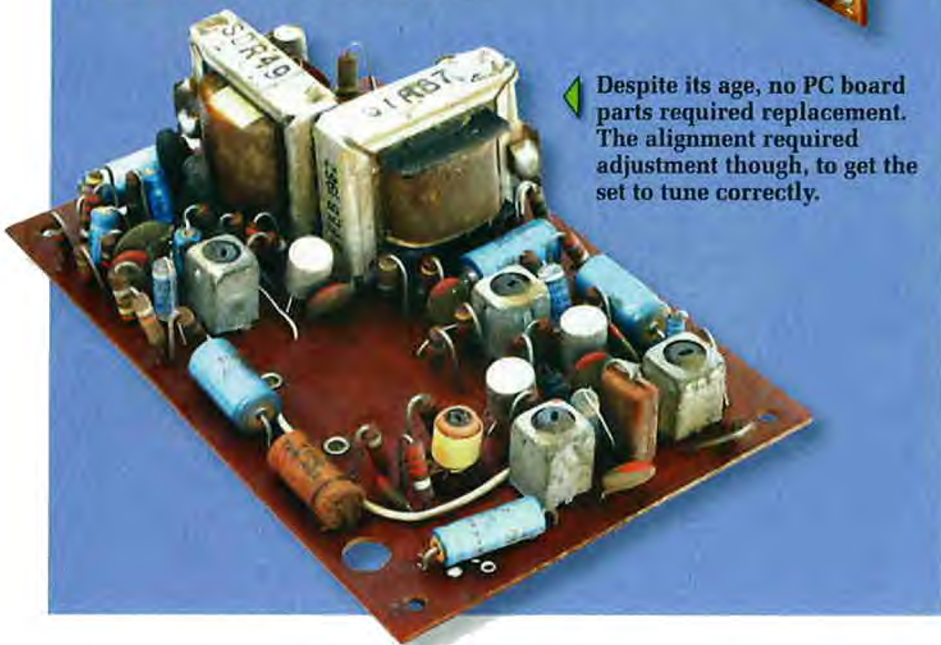

▲ Despite its age, no PC board parts required replacement. The alignment required adjustment though, to get the set to tune correctly.

original knobs obviously had a much narrower insert). This was done by carefully filing them with a needle-nosed file.

That done, the inner retaining screw for the tuning knob was cleaned and repainted with gold spray paint, as was one stud underneath the cabinet front. In addition, the dial pointer was sprayed with white paint, as it too was looking a bit grubby.

The speaker had some fluff trapped at the front of the cone, which meant it had to be removed. This involves first removing the PC board (more on this later), after which it's a matter of undoing the nuts and bolts that hold the speaker in place.

In the end, it was necessary to only

partially remove the speaker, after which the fluff was easily brushed out. The speaker was then correctly refitted into position.

Next, the cabinet and tuning knob were washed using soapy water, a nail-brush and a toothbrush. However, I did take care to ensure that the paper stickers didn't get wet. Any shallow scuff marks in the case were then removed using automotive cut and polish but there were also some marks that were too deep to get out – at least not without cutting well into the plastic case. However, the remaining scratches are not particularly obvious.

Removing the PC board

The PC board wasn't as easy to

remove as it could have been due to the location of the "earth", which is also the mounting plate for a screw holding the back of the set against the metal chassis.

First, the single-strand wire from the oscillator section of the tuning gang to the PC board has to be desoldered, after which the four screws holding the board in place are removed. The "earth" plate is then sprung outwards so that the board can be removed. In practice, the board can then be turned over (so that the parts face upwards) and a piece of cardboard or cloth placed underneath it to prevent shorts to the frame during testing.

This procedure could have been simplified by mounting the board in a slightly different position, so that it could be directly removed without the "earth" being in the way. In fact, with a little more thought, the board could have been hinged on the edge near the centre of the receiver, which would have made it a dream to service.

The old AWA P1 portable TV set had a hinged board and it made the set very easy to service. In fact, AWA did such a good job of making the P1 accessible that the picture tube could be replaced in 15 minutes.

Circuit details

The circuit configuration is similar to many other transistor receivers of the era – see Fig.1. It's a standard 7-transistor superhet circuit, with the front-end using an OC170 transistor as an autodyne converter.

Kriesler economised on the windings on the loopstick antenna by connecting the low-impedance section of L2 to both the base of TR1 (via R1, C1 & R3) and to the antenna via a broadly-tuned coil (L1). Coils used in the L1 position are usually tuned below the broadcast band when used with a 7-10m long antenna. This coil boosts the performance at the low-frequency end of the dial, as the performance here is usually inferior to that at the high-frequency end.

The output from TR1 is fed via 455kHz IF (intermediate frequency) transformers IFT1A and IFT1B to the base of the first IF amplifier (TR2, OC169). It then goes to IF amplifier stage TR3 (OC169) and from there to detector stage D2 (OA79) which also provides the AGC voltage. Resistors R17 and R18 forward bias D2 almost to the point of conduction, thereby

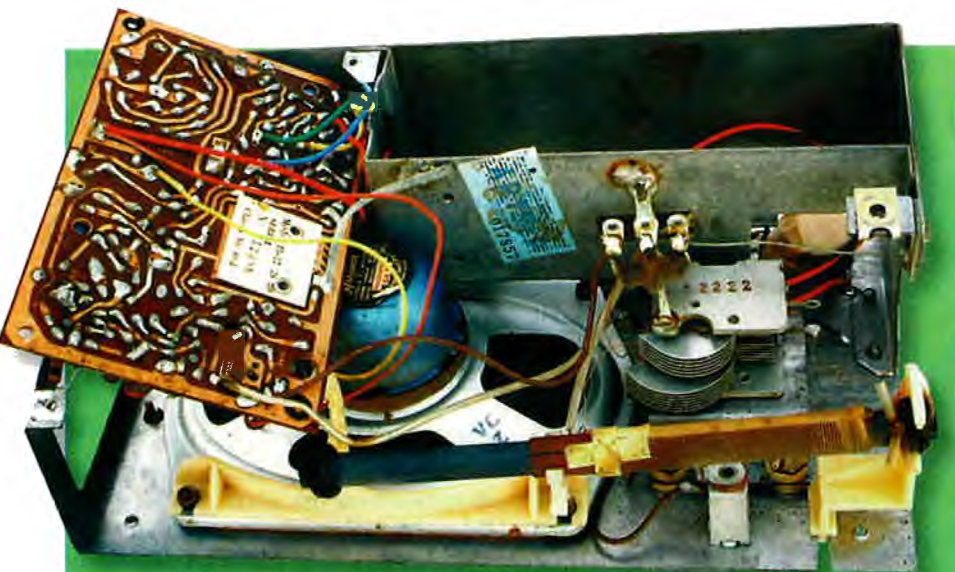

Despite its apparent simplicity, the Kriesler Model 41-29 Trans-Mantel is not all that easy to disassemble for service.

greatly increasing its sensitivity and reducing distortion.

As the signal strength increases, D2 applies an increasingly positive voltage to R10 and hence to the base of PNP transistor TR2. This AGC voltage in turn causes TR2 to draw less current as it cuts off. As a result, the voltage at the junction of IFT2 and R12 becomes more negative (note: the circuit is positive earth).

Now let's consider the action of diode D1 (OA90), which is effectively wired between the collector circuit of TR1 and the collector circuit of TR2.

Normally, D1 does not conduct as TR1's collector is at -7.1V and TR2's is -5.1V (ie, D1 is reverse biased). However, as TR2 shuts down due to AGC action, its collector voltage progressively becomes more negative. When this voltage goes below about -7.3V, D1 becomes forward biased and conducts, thus causing the signal from TR1 to largely bypass TR2 and go straight to TR3 (via IFT2).

As a result, the gain of the set is reduced on strong signals. At the same time, the selectivity is also reduced, as IFT1 is bypassed and only IFT2 and

IFT3 are effectively in circuit. This loss of selectivity probably doesn't matter a great deal and actually has the benefit of improving the audio quality on strong signals.

Following the detector, the audio is fed to volume control R21 and then to the first audio amplifier (TR4, OC71). This is then followed by audio stage TR5 (OC75) which in turn drives two class B audio transistors TR6 and TR7 (OC74s) via transformer T1. TR6 and TR7 operate in push-pull configuration and drive the loudspeaker via transformer T2. Negative feedback is applied from the loudspeaker voice coil to the emitter of TR5.

The output stage quiescent current is regulated by R37, a negative temperature coefficient (NTC) thermistor. Germanium transistors are particularly prone to thermal runaway as their temperature increases. In fact, it can be so bad in circuits like this that the transistors can self-destruct.

To overcome this, the NTC thermistor decreases its resistance with increased temperature, thereby reducing the forward bias on the bases of transistors TR6 and TR7. This compensates for the tendency of the TR6 and TR7 to conduct more heavily with increasing temperature.

In this circuit, the thermistor senses the ambient temperature inside the case but some later transistor equipment had the thermistor physically connected to the output transistor

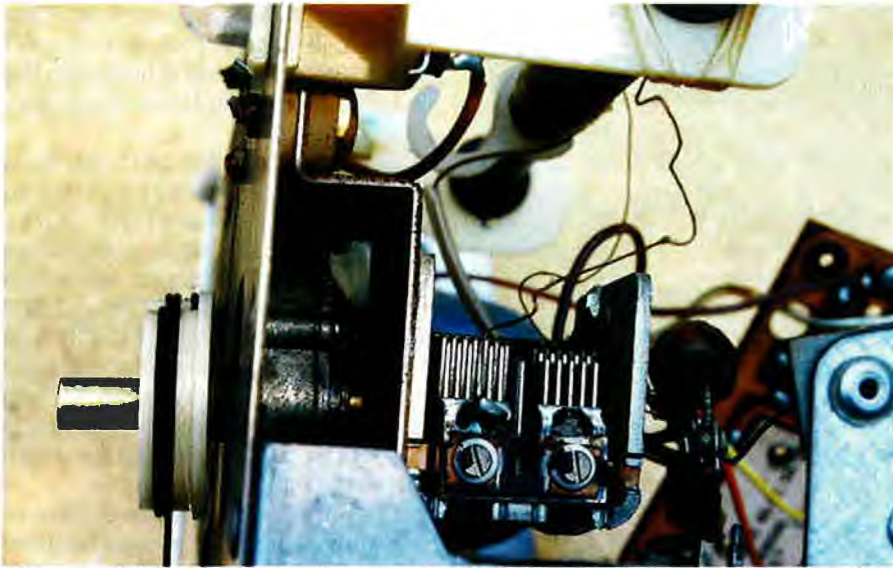

The geared drive for the tuning capacitor is inside the compartment to the left. This made difficult to drill a hole to lock the gear to the tuning capacitor shaft.

heatsinks to improve the response time and provide more effective control.

Restoration

Initially, this set was completely dead but this was quickly traced to a faulty on/off switch. Not having a replacement on hand, I decided to simply bypass the switch until a suitable control became available. The set then showed signs of working.

Next, I sat my Leader LSG11 signal generator on the other side of the workshop, so that it could provide a weak test signal for the set. This was tuned to 455kHz and I could immediately hear a beat tone from the radio, so it was quite a sensitive set.

The cores of the IF amplifier transformers had all been sealed but their alignment appeared to be pretty much spot on. However, I found that the set would only tune down to 600kHz in-

stead of the more normal 525kHz.

This was easily fixed. All I had to do was adjust the oscillator coil so that it tuned down to 525kHz with the gang shut, then adjust the oscillator trimmer so that it tuned to 1620kHz with the gang fully open. There seemed to be little interaction between these two adjustments so I then aligned the antenna circuit by adjusting the position of the loopstick coil for best performance at about 600kHz and the antenna trimmer for best performance at around 1500kHz.

The set was now working rather well and that was with no external antenna. In fact, it worked so well that the addition of an external antenna almost caused overload.

At this stage, I ran into a problem. The dial scale has a "start point" marked on it but I couldn't get it right. I tuned to either end of the dial and

the rest point for the pointer changed which wasn't good.

I then found that the plastic gear shaft on the dial reduction drive had expanded, so that when tuned to the end of the dial, you could keep turning it even though the tuning gang was now stationary. This was easily fixed by drilling through the plastic gear and the brass tuning capacitor shaft and then locking the two together with a wire pin.

Summary

Kriesler made many interesting receivers over the years and the 41-29 Trans-Mantel was an excellent little set with long battery life. The dial drive system is a little more complicated than needed and the PC board could have been mounted in such a way that it could have been hinged for easy service. However, these are comparatively minor quibbles.

Finally, note that the circuit indicates that the on-off switch is part of the volume control. In practice, it's part of the tone control instead, so someone didn't check the circuit too well.

Errata

In Vintage Radio for June 2004, I stated that the suppressor grid on a valve caught the electrons that bounced off the plate. This isn't strictly correct as the electrons that hit the plate dislodge other electrons, which are collected by the suppressor. This is called "secondary emission".

It has also been pointed out that the screen grid reduces the capacitance between the grid and the plate. This should have added to my statement that the screen grid screens the grid from the plate. **SC**