

Vintage Radio

By RODNEY CHAMPNESS, VK3UG

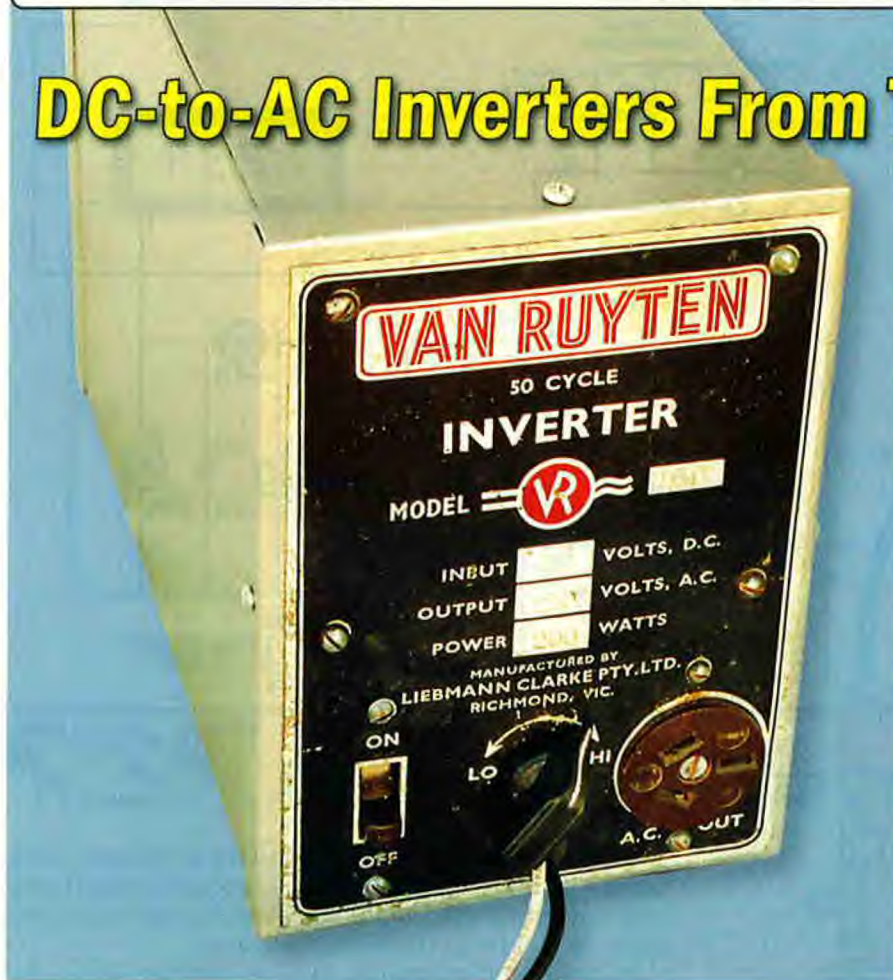

DC-to-AC Inverters From The Valve Era



There have always been odd little offshoots from the mainstream technology of radio and DC-to-AC inverters are one such offshoot. This month, we'll take a look at two of those early inverter circuits and describe their restoration.

DURING THE VALVE era, many radio manufacturers also made DC-to-AC inverters to power items such as electric shavers, TV sets and other 240VAC items from 6, 12 or 32V DC. However, with the exception of radiograms, 240VAC radios were rarely powered from inverters, as the inverters were not very efficient.

Getting some of those early inverters working again can be quite a challenge. So let's take a look at a couple of the more common units.

Bland's shaver inverter

Bland Radio Ltd of Adelaide were well-known for their Operatic series of good performance radios. They also

made various other devices, one of which was an electric shaver inverter. This ran off 6V DC and produced 240V AC with a near square-wave output waveform. Its current drain was approximately 4A for a power output of up to 15W.

My unit was obtained when a friend decided to reduce his radio collection. When I subsequently pulled the cover off the unit to see what was inside I found an Oak V5211 vibrator, an iron-cored transformer and a 0.5 μ F 600V buffer capacitor. These buffer capacitors can be unreliable so I immediately replaced it with a new polyester type with a slightly higher voltage rating than the original unit.

There being nothing else to check, I then attached the inverter to a 6V power supply and absolutely nothing happened. Further examination of the device then revealed that the inverter had to have a shaver or some other similar device connected to it to work.

Basically, the earth pin on the appliance's 240V plug is used as the switch to turn the device on – see Fig.1. As shown, the earth terminal on the inverter's 240V socket was modified so that it had two separate sections. Plugging in the appliance connected these two sections (via the earth pin on the plug), thus allowing the inverter to operate from the 6V supply.

In practice, this means that the inverter will not operate until a 3-pin plug is inserted. It then turns off automatically when you remove the plug. It's quite a neat scheme but I wonder how many men complained that the unit didn't work, not knowing that their shaver needed to have a 3-pin plug and not a 2-pin plug!

No voltage

Having solved that problem, the vi-

brator started but I still couldn't get any voltage out of the unit. An ohmmeter soon showed that the transformer was still OK so that left the vibrator itself, although it appeared to be working.

When the vibrator was removed from its case it initially appeared to be OK. However, the ohmmeter showed that all the contacts except for the reed drive had oxidised. So although they were making physical contact with each other, there was no conductivity across the contacts.

This is not a common problem but I've seen it before and the solution is quite simple. It's just a matter of cleaning the contacts using some very fine wet and dry paper.

The procedure is as follows. First, tear off a small amount of wet and dry paper about 20mm square. That done, fold it in half with the abrasive side out and insert the paper between each set of points. Finally, press the points lightly together and rub the paper back and forth between the points until they are clean.

In practice, several pieces of paper are usually needed to get the points thoroughly clean and conducting again. In this case, once cleaning had been completed, an output voltage of over 400V peak-to-peak was obtained with no load. I then put a 5.6kΩ wirewound resistor across the output and briefly obtained an output of about 260V before the unit suddenly stopped.

For such a simple device, it was certainly causing more than its fair share of trouble. I checked the circuit around the vibrator and the voltages around it were normal. I then re-checked the points and this time found that the reed drive had fouled up.

As a result, the points were all given a further clean-up, after which the unit worked well. I then checked the waveform on the oscilloscope and found what was nominally a square wave but with some slight resemblance to a sine wave. There was no significant overshoot on the waveform.

I don't have a true RMS meter to measure the output but according to the oscilloscope, it appeared to be producing roughly 240V AC.

Having got the unit working, I decided to trace out the circuit and it turned out to be a little different to most vibrator circuits. In this unit, the synchronous split-reed V5211 vibrator is wired so that the whole



This simple 6V DC to 24VAC inverter was made by Bland Radio Ltd of Adelaide and was designed to power electric shavers.

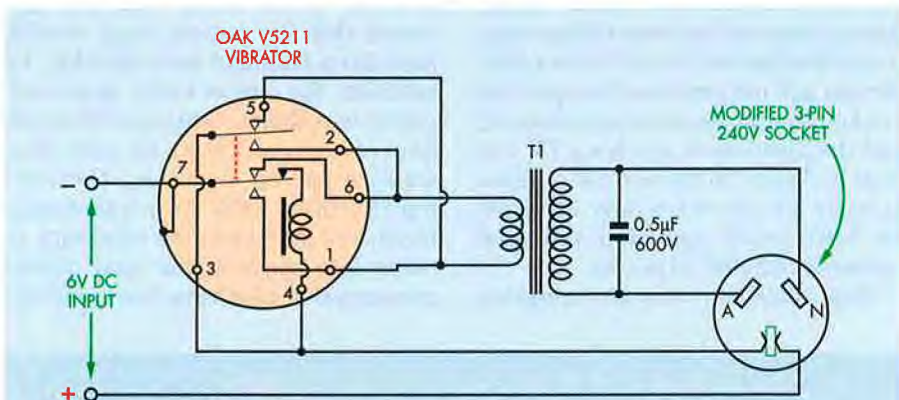

Fig.1: the Bland Radio inverter circuit. Its mains socket used a 2-piece earth terminal which functioned as a switch for the 6V DC input (a scheme that would now be illegal). This meant that the mains plug fitted to the appliance had to have an earth pin in order for the inverter to work.

primary winding is used but the current through the winding is reversed at the end of each half cycle.

Many vibrator inverters did not work well on inductive loads and shavers usually are inductive. However, there was no sign of excessive pitting on the vibrator contacts so it would appear that it did a satisfactory job, despite the nature of the devices likely to have been connected to it. In fact, Bland Radio's vibrator power

supplies were well designed and rarely required vibrator replacement.

Van Ruyten model VR58TV

Up until the late 1950s and even into the 1960s, 240V mains power was still not available to some farms and other remote areas. Instead, they mostly relied on 32V DC power plants for lighting but only some household equipment was designed to operate from this supply voltage.

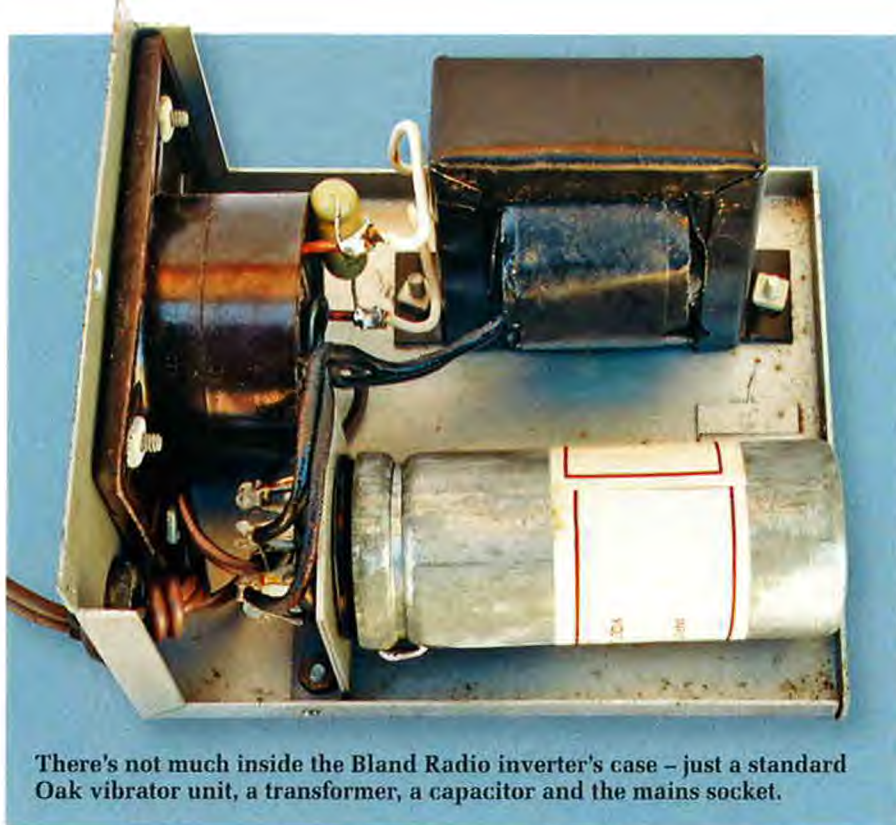

There's not much inside the Bland Radio inverter's case – just a standard Oak vibrator unit, a transformer, a capacitor and the mains socket.

Items like washing machines, electric irons, food mixers and vacuum cleaners were available but 32V refrigerators were not (kerosene refrigerators were used instead). A 32V 2-bar radiator was just not practical (an open fire or a kerosene heater were used instead) and the pleasure of watching TV was largely denied to these rural citizens as early TV sets were only designed for 240V mains operation and used upwards of 200W of power.

Now 200W of power consumption

was not in itself too much for a 32V system but the fact that people like to watch TV for many hours per day meant that the battery bank would have been flattened quite quickly. In addition, the cost of home generated power was about a dollar per kilowatt hour or more, which is a lot more than we now pay for electricity. Converting 32V DC to 240V AC is inherently inefficient and when the efficiency is taken into account, the total power consumption climbs to nearly 300W.

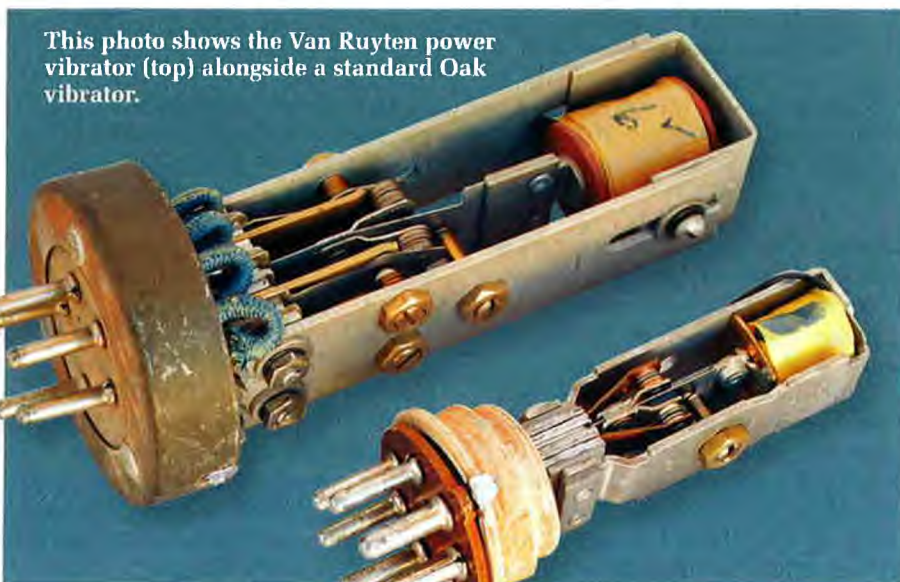

This photo shows the Van Ruyten power vibrator (top) alongside a standard Oak vibrator.

During that era, the only manufacturer to produce DC-powered TV sets was Ferris. These purpose-built set incorporated their own vibrator supply and were more efficient than mains sets operating from an inverter. However, despite the inefficiency and the cost, there was still some demand for inverters to run mains-operated TV receivers.

One well-known DC-AC inverter manufacturer was Liebmann Clarke Pty Ltd of Richmond in Victoria. The company manufactured several different models, designed to power 240V AC equipment from 6V, 12V or 32V DC.

Their highest power unit was the Van Ruyten model VR58TV. This 32V-to-240V inverter had an output power of 200W and weighed in at 10kg. It was specifically designed to power black and white TV sets from a 32V bank of batteries on a farm or station.

In fact, it would appear that the model number indicates the design year and that its prime purpose was to power TV sets.

Cleaning up

When I obtained the inverter, it looked pretty shabby, with rust showing through the paint work, the voltage adjustment knob missing and the front panel hanging loose. Unfortunately, I didn't have any knobs that exactly matched the type used so I used one that suited the era.

On the other hand, the inside of the inverter was quite clean and only a quick clean-up with a small paint brush was required. That done, I separated the unit from its case and removed the front panel. The case and its panel were then washed with soapy water and left to dry.

Once they had dried, I set about removing the rust and old paint from these items using an angle grinder. The two parts were then sprayed with grey hammertone paint and the unit now looks almost like new. It's certainly vastly better than the rusty unit it was before restoration.

Overhauling the electronics

It was now time to overhaul the works and my first step was to replace the 0.56 μ F 600V paper capacitor (C11) which was leaky as expected. This was swapped out for two 0.27 μ F 630V polyester capacitors wired in parallel. All the other capacitors were being run

well under their voltage ratings so I left them in circuit. That proved to be a mistake but more of that later.

The vibrators in these inverters often had a hard life due to the uncertainty of whether the load would be inductive or capacitive. C5-C8 and C11 are the buffer capacitors which “tune” the inductances so that the circuit resonates to around 50Hz.

However, with capacitive or inductive loads, this tuning will be altered, leading to sparking at the vibrator points.

I don't have any spare 32V vibrators so I dismantled the unit that was in the inverter. This was done by desoldering the two solder joints between the base and the can and then sliding the vibrator out.

A close inspection of the points showed that one pair out of the five sets had a “dag” on one contact which mated with a hole in the other point. This was fixed by releasing the adjustment screw and filing the dag away. I then cleaned all the points with fine wet and dry paper.

That done, I re-installed the adjustment screw and rotated it until I had the same gap as the other parallel set of points. A feeler gauge was then used to make the adjustment as accurate as possible. I then connected the vibrator to a 12V supply to check that the reed drive worked properly.

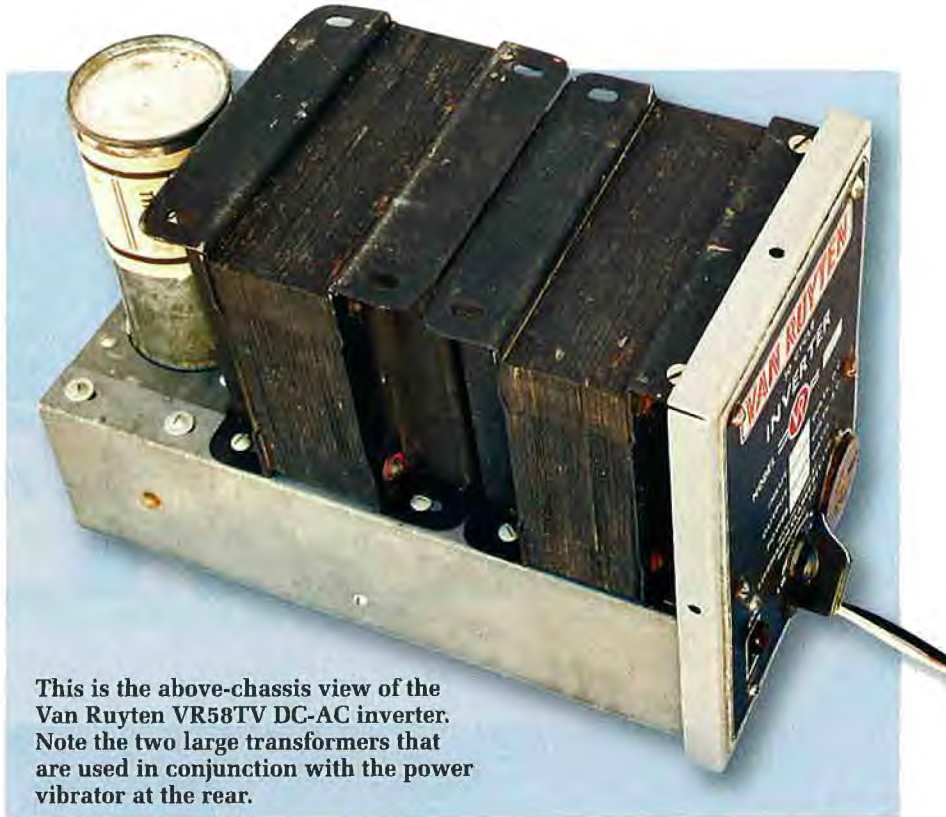

This is the above-chassis view of the Van Ruyten VR58TV DC-AC inverter. Note the two large transformers that are used in conjunction with the power vibrator at the rear.

This checked OK and required only a minor adjustment.

Re-assembly

The next step was to re-assemble the inverter. First, the 32V power leads and the grommet were fed through the hole at the bottom of the panel, then the switch was mounted in position,

followed by the 240V output socket.

The 32V switch was next on the list and this proved to be difficult, as the screws are hard to get at. Eventually, I got them in but then found that the switch wouldn't work – much to my frustration.

On inspection, it appeared to be fouling on the switch cut out on the

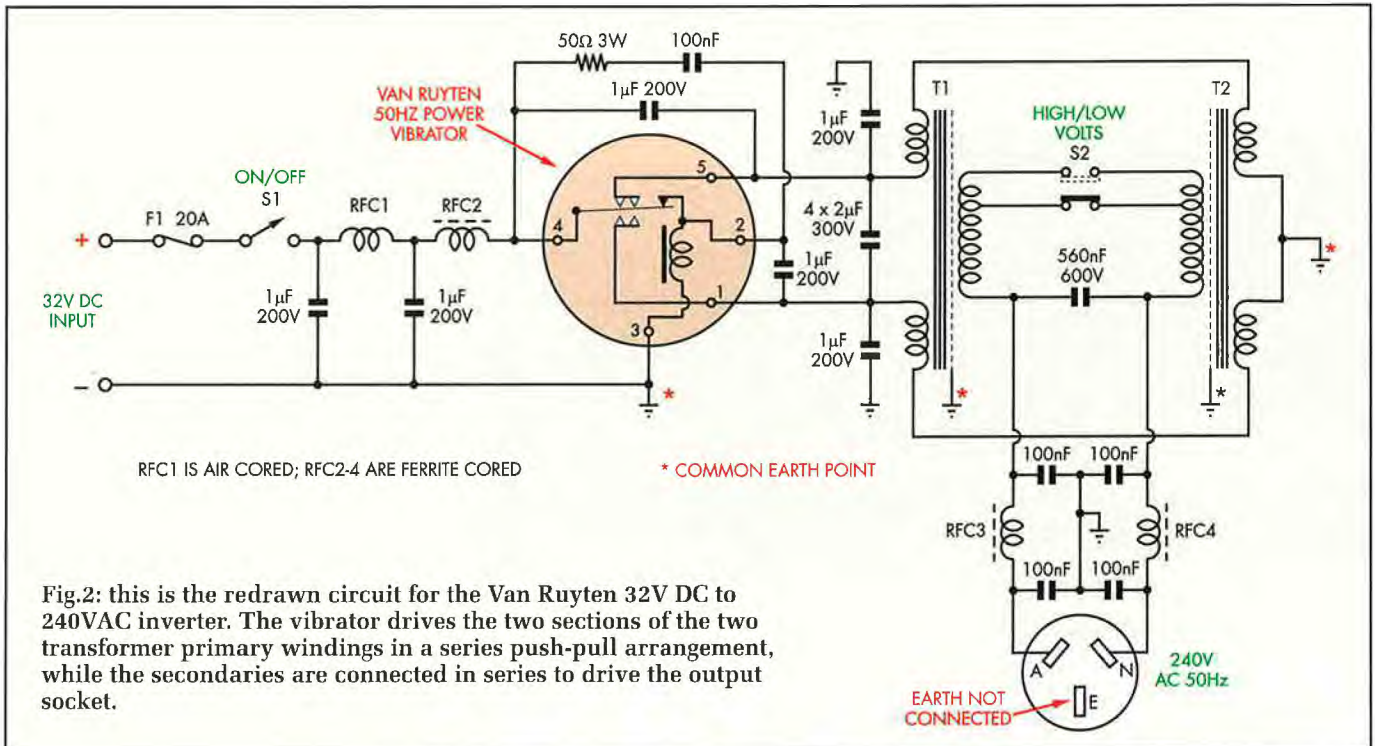
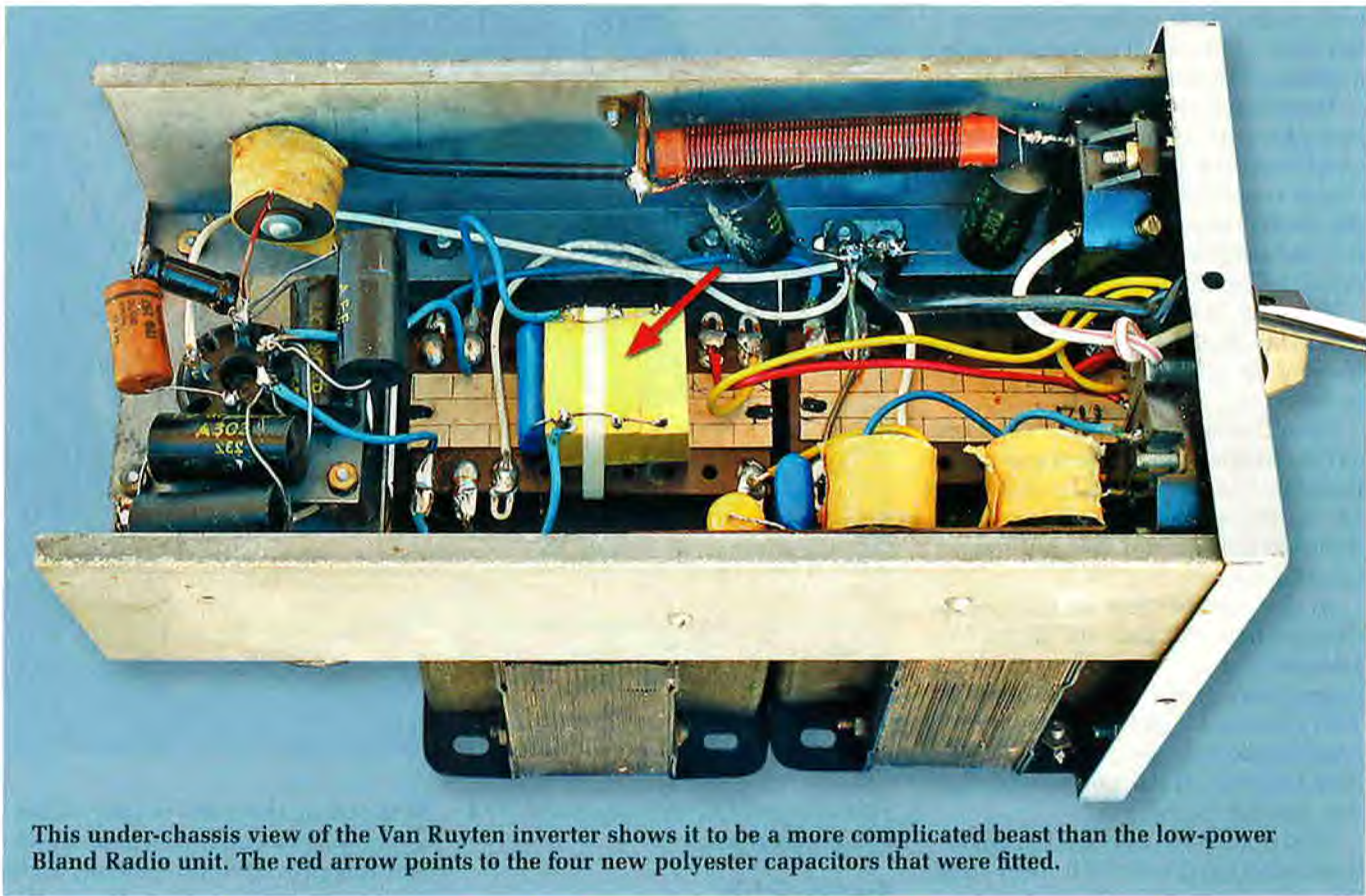

Fig.2: this is the redrawn circuit for the Van Ruyten 32V DC to 240VAC inverter. The vibrator drives the two sections of the two transformer primary windings in a series push-pull arrangement, while the secondaries are connected in series to drive the output socket.



This under-chassis view of the Van Ruyten inverter shows it to be a more complicated beast than the low-power Bland Radio unit. The red arrow points to the four new polyester capacitors that were fitted.

front panel. Fortunately, the previous owner had left all the screws, nuts and bolts for the inverter in a plastic bag. Much to my delight, there were also two ceramic spacers in the bag and it appeared they had been used as spacers for the switch.

Getting the nut onto the screw nearest the top of the chassis (furthest into

the chassis) was no easy task. Eventually, I resorted to an old trick. The nut was pressed into the end of a plastic tube, after which I was eventually able to position it inside the chassis correctly to take the screw. The one towards the bottom of the chassis is much easier but I now know why the previous owner passed the unit on to

me – he couldn't get it back together!

The knob I selected for the High/Low switch had a white recessed indicator line down the pointer section. However, this had largely disappeared so I scraped out the old paint using a scribe and cleaned it thoroughly. I then used "White Out" to fill the groove in the knob.

Once this was dry, the excess was scraped off the knob using a razor blade, leaving a neat white line down the channel in the pointer. It now looks like new.

It was now only a matter of sliding the chassis back into the case and fitting four screws. In addition, the rubber feet had long since disappeared from the bottom of the case so I used four large rubber stick-on furniture-type buffers to stand the case proud of the bench. These can be obtained from hardware or "\$2" shops. The finished unit now looks quite attractive, especially when compared to the grubby unit it was before restoration.

Testing

Now it was time to test the unit. I slipped it out of the case, connected my 32V DC power supply to it and con-



This is the Van Ruyten inverter's case before restoration. The rust was removed using a drill fitted with a wire brush, after which the unit was repainted so that it now looks almost like new.

nected a 15W 240V lamp to the output as a load. This load was deliberately kept small as my 32V supply is only rated at 1.5A.

At this stage, I still had the cover off the vibrator. I turned the power on and the unit started up and produced an output. Everything appeared to be OK, so I left it running on soak test.

Unfortunately, it didn't stay that way for long – the next time I came back, there were tiny bits of silver paper and other tiny bits of powdery material like confetti near the inverter. The inverter was still running quite happily so I turned it off to investigate. When I looked under the chassis, I was greeted by two capacitors that had blown their insides out.

The two capacitors involved were among the primary circuit buffers (C5-C8). They had overheated so badly that foil had been blown out of them. The inverter had kept going despite this catastrophic failure and none of the foil shorted anything out.

It was easily fixed – the “confetti” was cleaned out and the four capacitors (which were still quite hot) removed from the chassis. These original paper capacitors were then replaced with a batch of four polyester type capacitors.

As shown in one of the photos, the replacement capacitors were glued together with contact adhesive and then tied to the tag strip on the bottom of one of the transformers using a plastic cable tie.

Why did they fail?

The original paper capacitors are rated at 300V working, so why did they “blow up” when only 32V was being applied across them?

The answer is that the actual voltage across them is in fact considerably higher than the supply voltage, as the circuit is roughly resonant at 50Hz. As a result, considerable voltage is developed across the total inductance of the primary windings as they are completely charged and discharged 100 times a second.

I hadn't checked for leakage across these capacitors as I had reasoned (erroneously) that even if they did have some leakage, it would not be serious enough to cause much heating. How wrong I was. The two that hadn't blown up showed very low insulation resistance, so how low was the resistance in the two that did blow up?

Photo Gallery: Astor Mickey Model DL



MANUFACTURED BY RADIO CORPORATION, MELBOURNE in 1947, the “DL” was another model carrying the “Mickey” name. It was fitted with a full-width (almost) glass dial, with the loudspeaker mounted at the side of the cabinet. This set did not employ the reflex circuit that was later to become popular with “Mickey” models until the end of the series. Brown and cream were probably the most common cabinet colours and this mottled yellow example is unusual.

The valve line-up was as follows: 6A8-G frequency changer, 6B8-G reflexed IF amplifier/1st audio amplifier/detector/AVC rectifier, 6V6-GT audio output and 5Y3-GT rectifier. Photo: Historical Radio Society of Australia, Inc.

In hindsight, I should have tested these capacitors for leakage resistance before starting the unit up and then I should have periodically (every few minutes) checked for any signs of overheating.

Summary

These vibrator-powered DC-to-AC inverters served the needs of the public quite well before the arrival of solid-state devices. A number of other brands were also produced although they were not as common as the Van Ruyten.

Van Ruyten also produced a 100W version of the unit described above and it used just one transformer. The radio frequency (RF) filtering in the Van Ruyten unit may be sufficient so as not to noticeably impair domestic radio reception but the Bland Radio unit

has no such RF filtering. As a result, the reception on any radio used with the Bland Radio unit would have been severely marred by interference due to sparking at the vibrator points.

Based on my experience, these vibrator-type inverters were only moderately reliable due to the uncertain characteristics of the loads that they drove. By contrast, the Davey rotary motor alternator was a very reliable device which produced sinewave 240V AC, compared to the roughly square-wave output from the vibrator inverters. They also were not affected to any extent by the type of load that was connected to them.

However, the Davey units were rarely seen as they were even more expensive than the vibrator inverters and drew even more current from the 32V DC power supply. **SC**