

Vintage Radio

by PETER LANKSHEAR

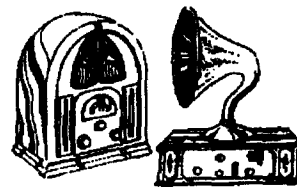

Rewinding output transformers

A frequently encountered problem in servicing valve radios is that of open-circuited audio transformer windings. Suitable replacements are hard to find, creating a serious problem in restoration projects. This month, we describe a practical method of using simple tools to rewind speaker transformers.

As explained in my previous column, transformer failures are generally the result of electrolytic corrosion of fine wire, the culprit being acidic paper insulation. Often this is the reason for a valve radio having been 'retired' as unservicable.

During the valve era, such was the rate of failures that there was a thriving trade in winding replacement transformers, making them readily available at competitive prices. There is no alternative to replacing or rewinding a defective transformer, but today production of audio transformers has ceased, leaving the vintage radio enthusiast with a major problem.

If you are lucky, you may locate a re-winding specialist, but his services can be expensive. Usually, restorers resort to 'cannibalising' transformers from other radios, or substituting unsuitable transformers intended for other duties — neither of which are very satisfactory alternatives.

Machinery not essential

Many vintage radio enthusiasts regard transformer winding as a 'black art' requiring considerable expertise and expensive machinery, and will not treat seriously any suggestion that rewinding an output transformer can be done in the home workshop.

Certainly, the traditional method of winding several thousand turns of fine primary wire — interleaved with paper — can, when done by hand, be a daunting task; although it has been done. Fortunately, using modern materials, it is unnecessary to display such patience. Modern wire coverings are so reliable and durable that today, as a study of a modern small transformer will reveal, fine gauge windings are simply piled on randomly without any interleaving paper on to molded bobbins, available in a

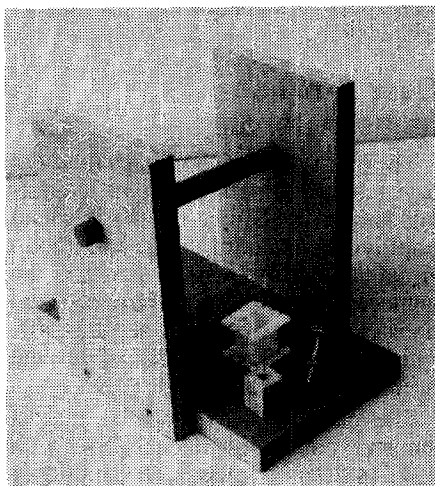

Fig.1: The equipment required is minimal — a spool holder, a mandrel and a 6mm bolt with washers.

wide range of sizes. Even mains transformers are now made this way, with little risk of breakdowns.

As the photographs show, the only essential tools for transformer winding are

a small vice, a hand drill, a long bolt with washers, and a simple support for a reel of wire. The drill is clamped in the vice and is used to rotate the bobbin mounted on the bolt. The main requirement for the reel support is that it should allow the reel to turn freely with a minimum of friction. Ideally, a spindle with threaded cones and running in ball races would be used, but a wooden dowel that is a close fit in the reel is quite satisfactory.

Remove and dismantle the transformer. If it is mounted on the loudspeaker, take care when you are drilling out rivets that metal particles don't get into the voice coil area. As speakers with energised fields generally have a humbucking coil in series with the voice coil and secondary winding, take a note of the connections.

Opening it up

Now open any tabs locking the cover to the core. The cover can be prised off and the core separated from the winding. Unless the receiver has a pushpull output

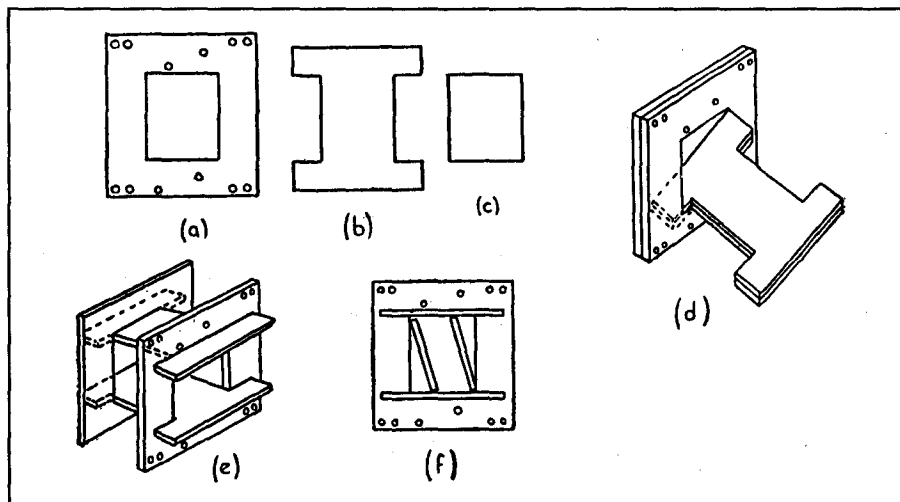

A method of making your own bobbin, using thin fibre board or Formica.

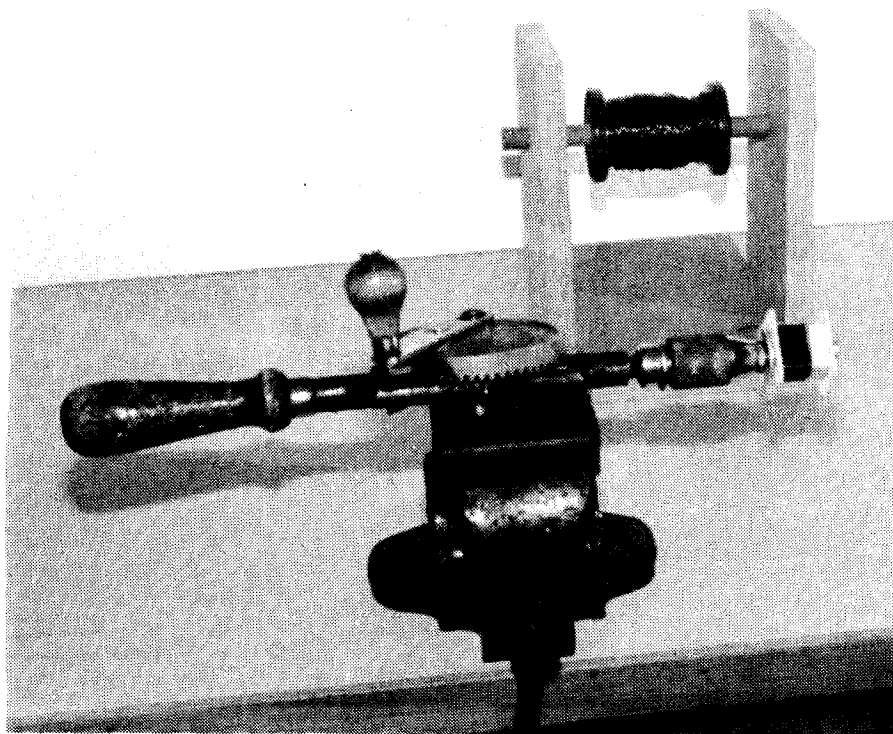

Fig.2: The simple setup, with a partly completed secondary winding visible.

stage, the E and I core laminations will not be interleaved, but simply butted together with a piece of thin paper as a spacer.

An original winding will have been made in the traditional manner, with alternate layers of wire and paper on a fibre or cardboard rectangular tube. Peel off the outer paper or tape and the thick outer secondary or voice coil winding will be uncovered. Unwind this wire, noting the number of turns, typically somewhere between 50 and 100.

Underneath a layer of insulation will be the primary, consisting of several thousand turns of fine wire. Counting them would be a tedious business, likely to put anyone off transformer winding forever. However, this is unnecessary as calculation is quite easy.

New bobbin

A wide range of plastic bobbins is made but it may take a bit of shopping around to locate a source. Although generally not stocked by the major electronic supermarkets, smaller suppliers often have transformer bobbins available, or know where to get them. Take along your core to make sure that you get the right size. If you are unlucky enough not to be able to obtain a suitable bobbin, a very practical method of fabrication from thin fibre or Formica is shown in the diagram.

A typical transformer does not require

a lot of wire, but small quantities purchased from electronics suppliers can be prohibitively expensive. A full reel is much more economical, but would provide sufficient wire for a lifetime of re-winding. It may be possible to buy a part reel from a motor re-winder or similar firm.

For all but the smallest transformers, a suitable wire for primaries is 0.125mm (39swg) and for secondaries, 0.5mm (24swg). Use 0.11mm (41swg) and 0.4mm (27swg) respectively for the very small '3 watt' transformers.

TRANSFORMER RATIOS		
VOICE COIL IMPEDANCE	ANODE LOAD 5K OHMS	7K OHMS
2.0 OHMS	50:1	59:1
2.3 OHMS	47:1	55:1
3.5 OHMS	38:1	45:1
5.0 OHMS	32:1	37:1
8.0 OHMS	25:1	30:1
15.0 OHMS	18:1	22:1

LOADS FOR SOME FREQUENTLY USED VALVE TYPES	
1,000 OHMS:	6P6, 42, 6BJ5, 6BV7, 4759, EL3, EL33, 6AG6G, KT63, 6DQ6/EL84, 2A5, 41, 6K6, 6CL66/8GWS
5,000 OHMS:	6AQ6/8HG5, EL90, 6V6, 6BW6

The next step, using a soft straight grained wood, is to make a mandrel to locate the bobbin on the 6mm bolt. Take care to ensure a snug fit and make it slightly shorter than the bobbin. Drill a 6mm hole, as accurately centred as possible. Any eccentricity will make even winding difficult. Assemble the washers (which relieve winding pressures on the bobbin walls), the mandrel and bobbin on to the bolt. Count the number of teeth on the drill gear wheels. For example, the drill illustrated has 56 and 15, so that for each turn of the handle there are 56/15 chuck revolutions. Now clamp the drill horizontally in the vice and tighten the bolt firmly in the drill chuck.

Secondary first

Traditionally the secondary was the outside winding, but there is no practical difference in performance if it is wound on first — which, with this method of re-winding, is more convenient.

Leave a few inches of secondary wire protruding through one of the slots and wind on a layer tightly and evenly. Check the number of turns and compare with those on the original winding. It is not essential for the final layer to occupy the full width of the bobbin, but it does provide a more level surface for the next winding. A variation of 10% in the total number of turns is quite acceptable. The transformer illustrated took 38 turns on the first layer, and the total for the original winding was 70. Two full layers came to 75 turns, which is quite close enough to the original. A piece of thin plastic tape was interleaved between the layers.

To complete the secondary, the end of the wire is brought out through a slot and the winding covered with two layers of plastic tape or plasticised paper (the paper backing for adhesive labels is ideal). This is cut a little wider than the bobbin to eliminate any possibility of primary turns dropping down on to the secondary.

Calculating the primary

Knowing the load for the output valve, the number of secondary turns, and the voice coil impedance, it is easy to calculate the primary turns required. The load impedance may be printed on the transformer or can be checked on a valve characteristic chart. Loads for some of the most frequently used valves are given in the accompanying table.

Sometimes beginners are confused to find that the DC resistance of a winding as measured by a test meter is only a fraction of the load impedance. Impedance in this case is the AC resistance of

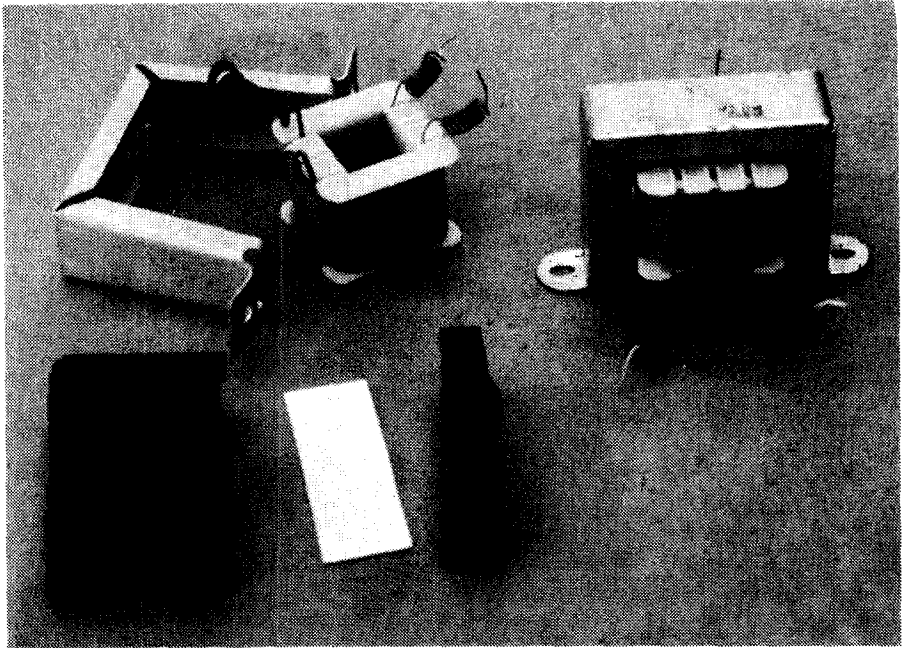

Fig.3: A completed winding, paper spacer, laminations and clamp, with a reassembled transformer.

the voice coil, as reflected by the transformer, and with practical transformers is of the order of 10 times the DC resistance of the primary.

Many 'one inch' voice coils had a nominal impedance of 2.3 ohms and the 3/4" coils fitted to lightweight speakers were usually 3.5 ohms. In any event, as loudspeaker impedances vary wildly with frequency, these figures are quite nominal. As a guide, voice coil impedance is about 1.3 times the DC resistance.

The required turns ratio of an output transformer is the square root of the impedance ratio. For example, if a 6F6G requiring a load of 7000 ohms is to match a 3.5 ohm speaker, the required impedance ratio is $7000/3.5$ or 2000:1. The turns ratio therefore, is the square root of 2000 or 44.7:1.

Some of the most common ratios are in the table. In our example, as the secondary has 75 turns, for an impedance ratio of 2000:1 the primary should have $75 \times 44.7 = 3350$ turns.

Winding the primary

This is one of the easiest parts of the project and takes only about 10 minutes. As the drill is geared the number primary turns required is divided by the gear ratio. In the example, this is $3350 \times 15/56 = 897$ turns of the drill handle. As it is easy to lose count, I use a pencil and paper to keep a tally during winding.

Terminate the start of the primary wire

with a short length of thin hookup wire, making sure that there are no lumps of solder. Bring this lead out through a slot on the opposite side of the bobbin from the secondary leads.

Position the hookup wire so that it goes the full width of the bobbin and fasten it down with a piece of tape, making sure that the splice is completely covered.

Maintain tension

Commence winding, turning the drill handle steadily with one hand and guiding the wire with the other. Maintain a slight tension on the wire, building up the winding evenly. Take care not to drop turns over the edges of the bobbin.

At the finish of winding, use another piece of thin hookup wire for leading out. To lock this wire in position, fold the end into a 'U' so that it crosses the winding twice, inserting a piece of tape between it and the winding and fasten it down with another piece of tape.

After covering the outside of the winding with a couple of layers of tape, or varnished paper, all that remains is to reassemble the bobbin and core, not forgetting the piece of paper in the gap between the two bundles of laminations.

You will now have at small cost, a transformer with a performance equal to the original, and with the advantage that it will be much more reliable.

Why not give it a try? ■